



*The definitive
collection of
Charles M. Schulz's
comic strip
masterpiece*

**INTRODUCTION
BY PRESIDENT
BARACK OBAMA**

**DAILIES AND
SUNDAYS
PLUS Li'l FOLKS**

**1999
TO
2000**

THE COMPLETE PEANUTS

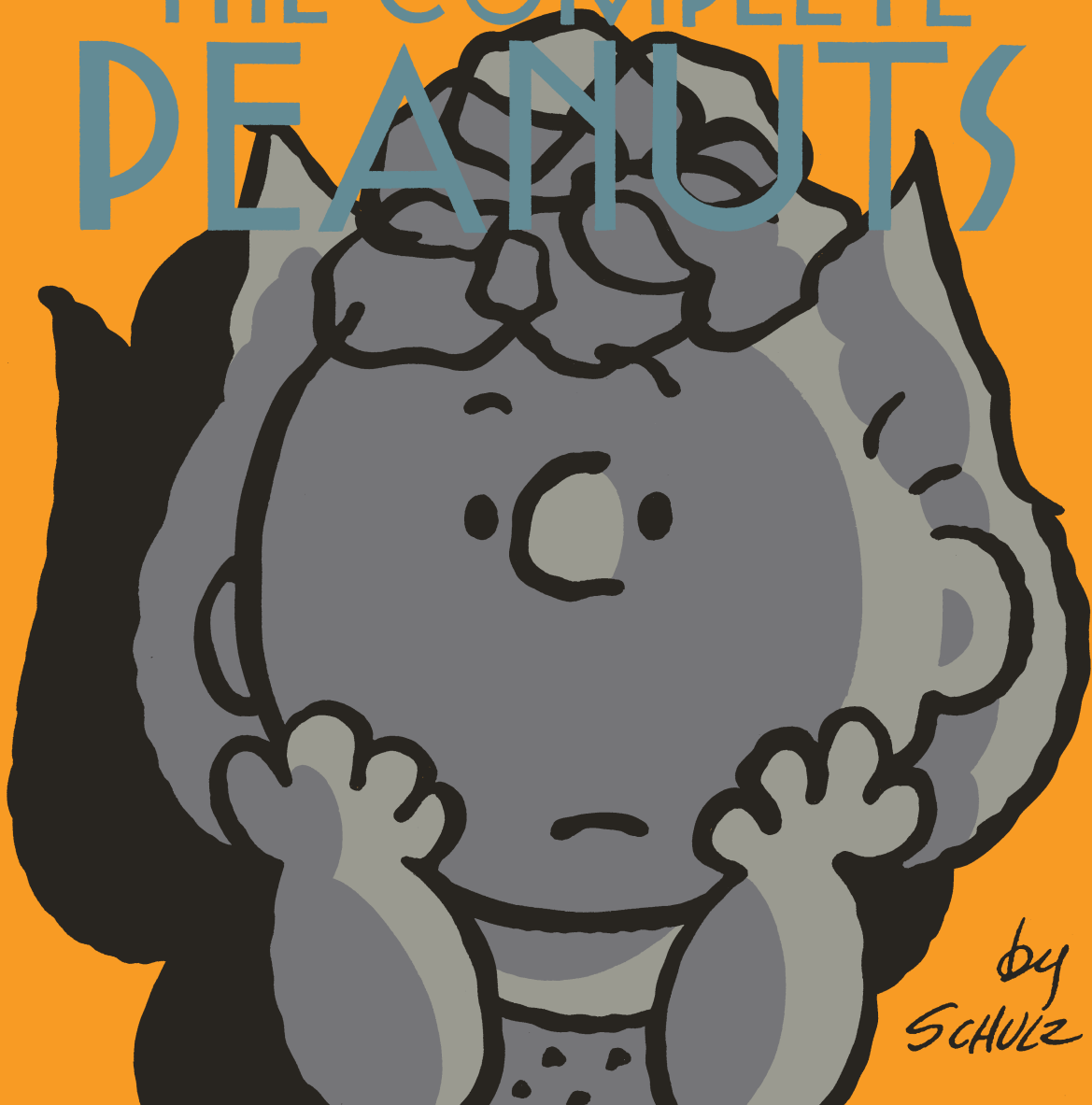

*by
SCHULZ*

The
Complete
Peanuts

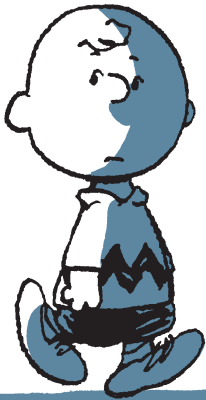

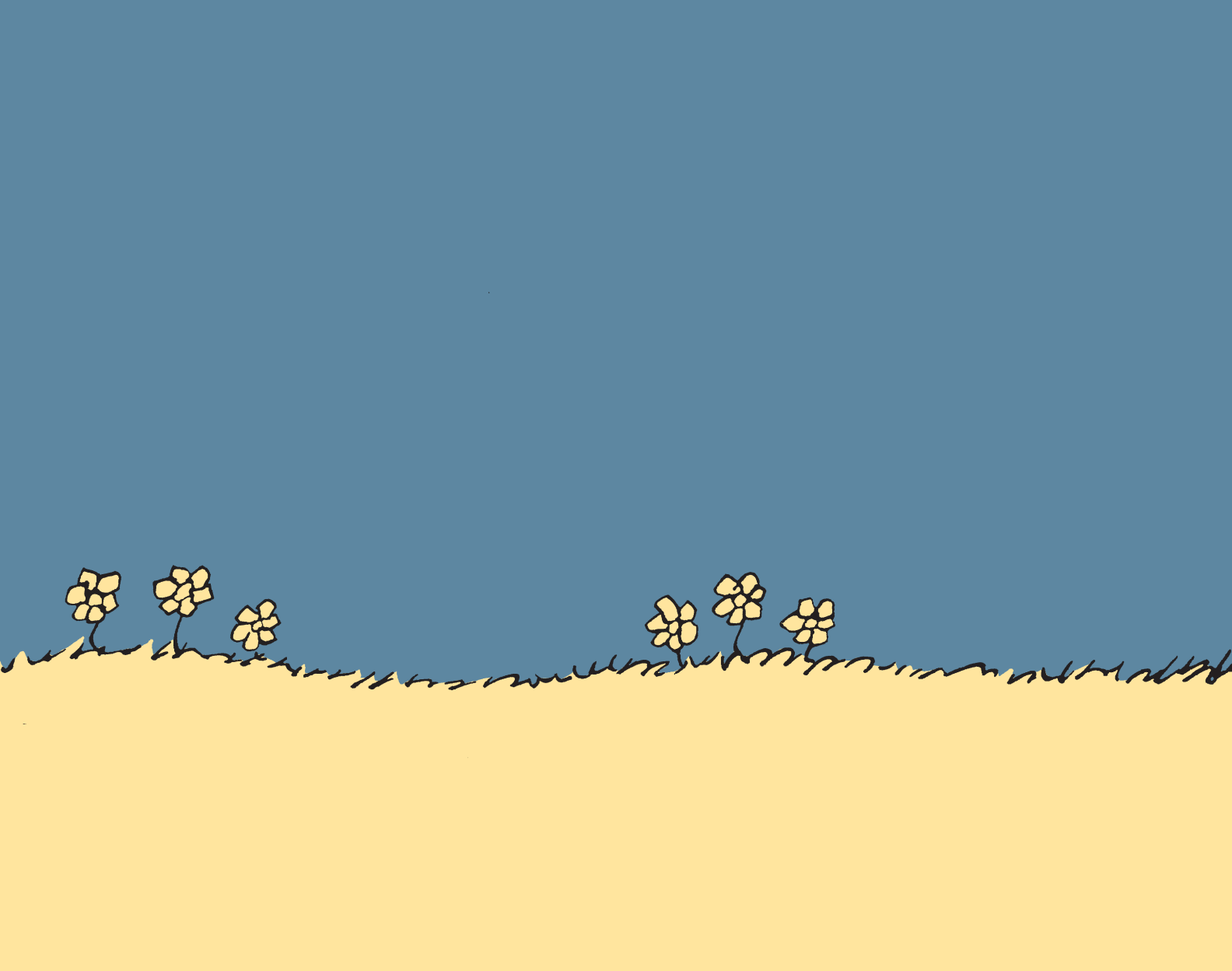

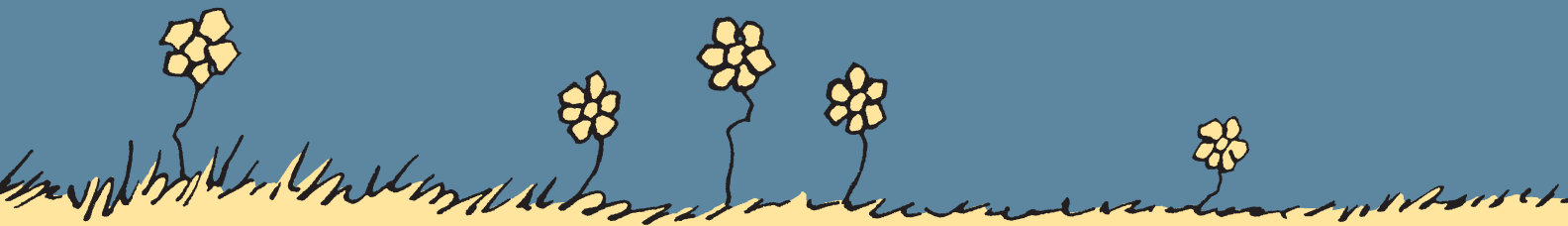

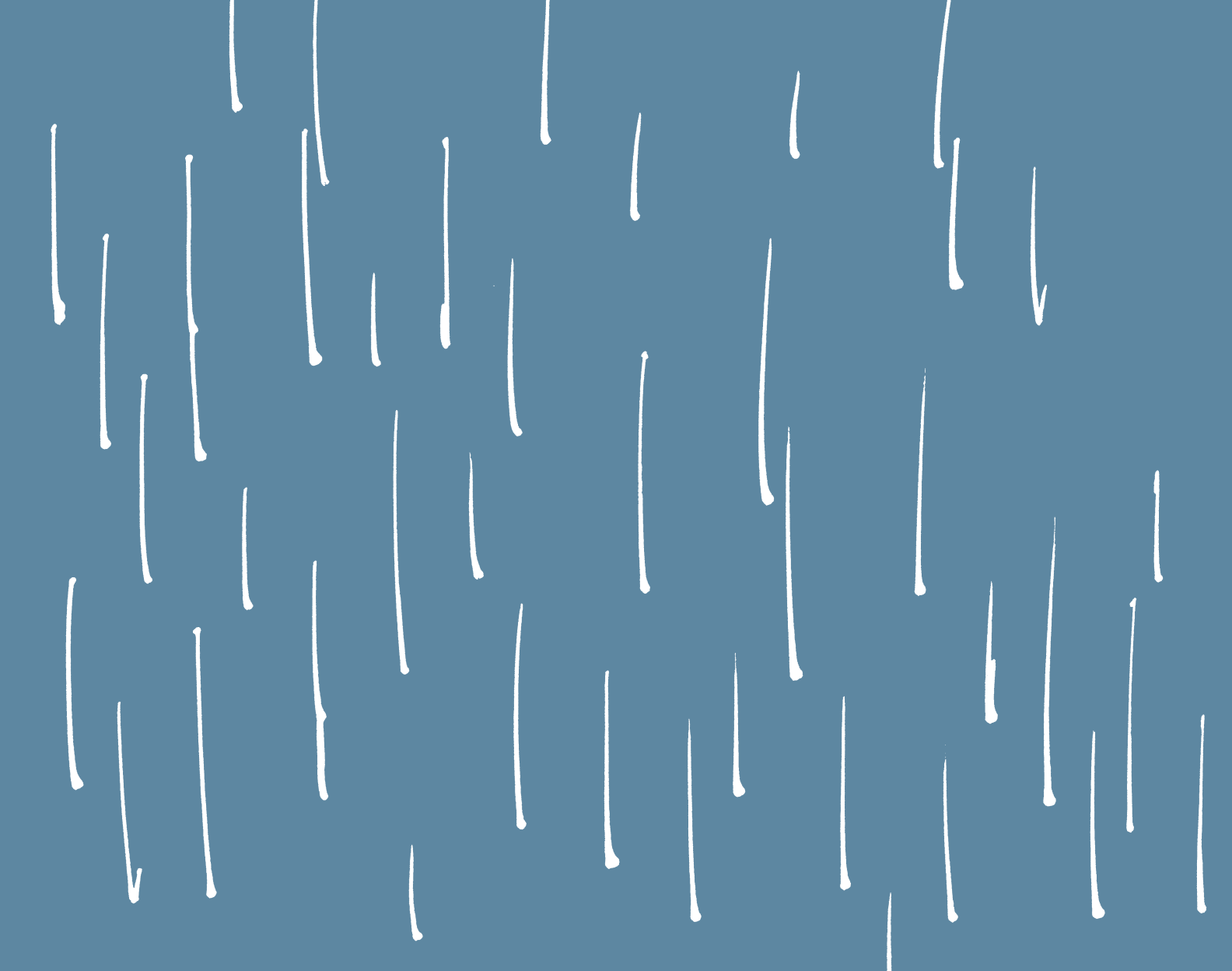

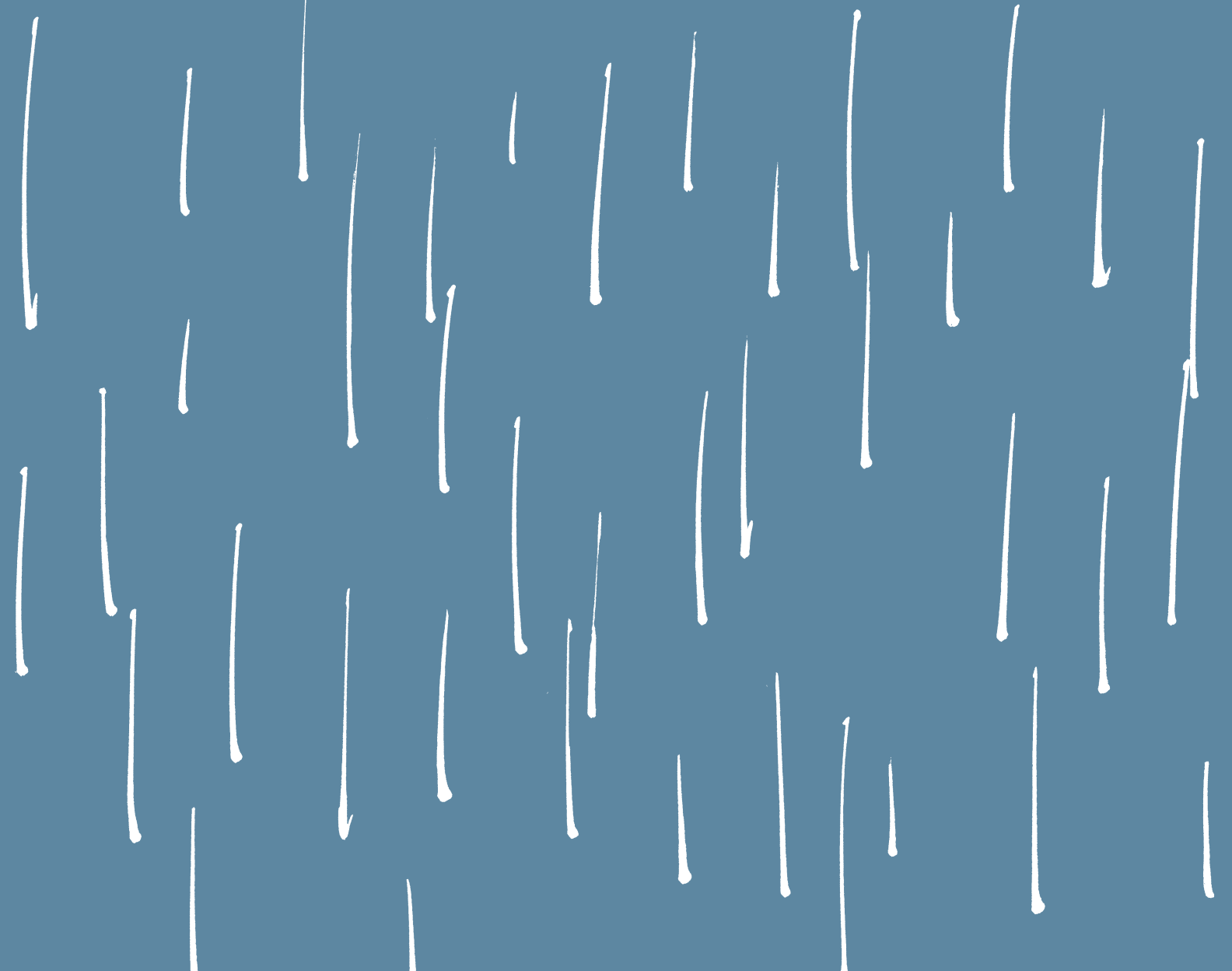

THE COMPLETE PEANUTS

by Charles M. Schulz

published by

Fantagraphics Books

Editor: Gary Groth

Designer: Seth

Production, assembly, and restoration: Paul Baresh

Archival assistance: Marcie Lee

Index compiled by Emily Hendrickson, Erin Keaton, and Emily Silva

Associate Publisher: Eric Reynolds

Publisher: Gary Groth

Special thanks to Jean Schulz, without whom this project would not have come to fruition.

The Complete Peanuts: 1999-2000 (Volume Twenty-five) is copyright © 2016 Peanuts Worldwide, LLC.

“Charles M. Schulz: 1922 to 2000” is copyright © 2016 Gary Groth. All rights reserved.

Permission to duplicate materials from *Peanuts* comic strips must be obtained from Peanuts Worldwide.

Permission to quote or reproduce for reviews and notices must be obtained from the respective copyright holders. The official *Peanuts* website can be accessed at www.peanuts.com.

Fantagraphics Books, 7563 Lake City Way NE, Seattle, WA 98115, USA.

For a free full-color catalog of comics, call 1-800-657-1100 or visit www.fantagraphics.com.

ISBN: 978-1-60699-913-4

Library of Congress Control Number: 2015959060

First printing: May 2016 Printed in China

CHARLES M. SCHULZ

THE COMPLETE
PEANUTS

1999 TO 2000

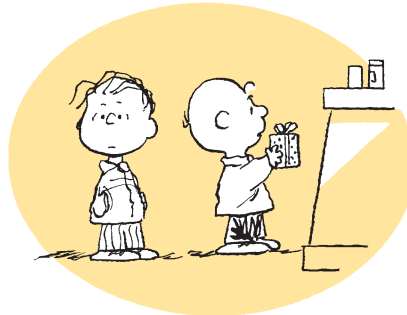

"YES, MA'AM..I'D LIKE TO
RETURN SOMETHING I
BOUGHT HERE.."

▣ FANTAGRAPHICS BOOKS ▣



Charles M. Schulz in his home studio at the drawing board, Santa Rosa, California, mid-1990s: courtesy of the Charles M. Schulz Museum.

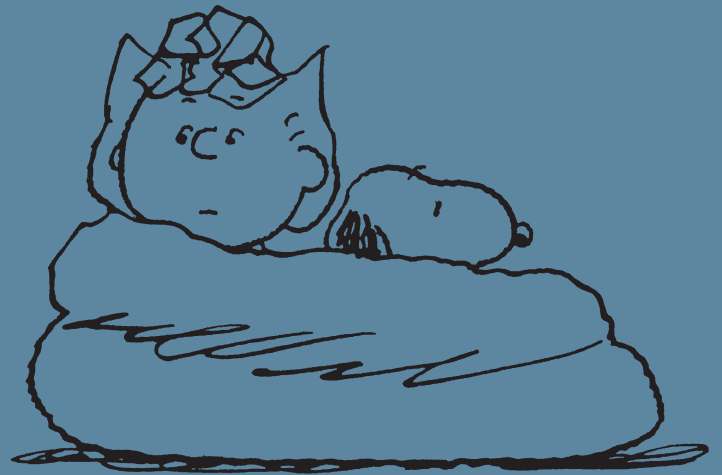

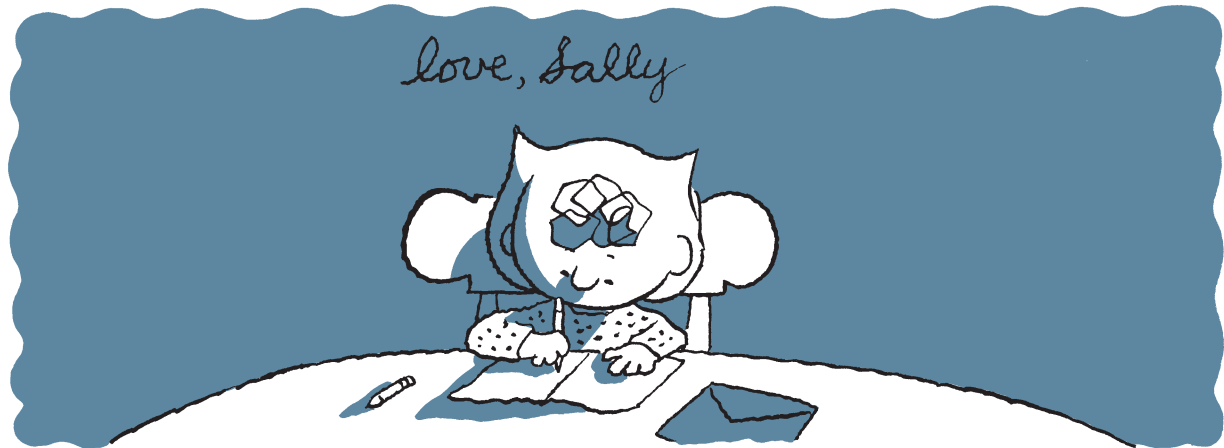

FOREWORD by PRESIDENT BARACK OBAMA

Like millions of Americans, I grew up with *Peanuts*. But I never outgrew it.

Wherever I lived, wherever I traveled, I could find those three or four panels in the paper each morning. And Charlie, Snoopy, Linus, Lucy, Franklin, and the gang brought childhood rushing back.

That's what made Charles Schulz so brilliant — he treated childhood with all the poignant and tender complexity it deserves. He gave voice to all its joys and anxieties — a spectrum of emotions that run from the start of a new baseball season to the anguished “AUGH” that comes with losing the big game. He explored the emotions that we too often forget kids feel until we're reminded that we once

felt them ourselves. Hope. Doubt. The exquisite pain of unrequited love. The self-exploration of what it means to be different. The comfortable knowledge that it's all going to be OK — even if Lucy's advice isn't very good.

For decades, *Peanuts* was our own daily security blanket. That's what makes *Peanuts* an American treasure.

In his final strip, Charles Schulz wondered how he could ever forget the *Peanuts* gang. Thanks to this groundbreaking series of books collecting all of Charles Schulz's *Peanuts* strips, the rest of us never will — and we can share our love for the gang with our children and grandchildren for decades to come.

1999
TO
2000

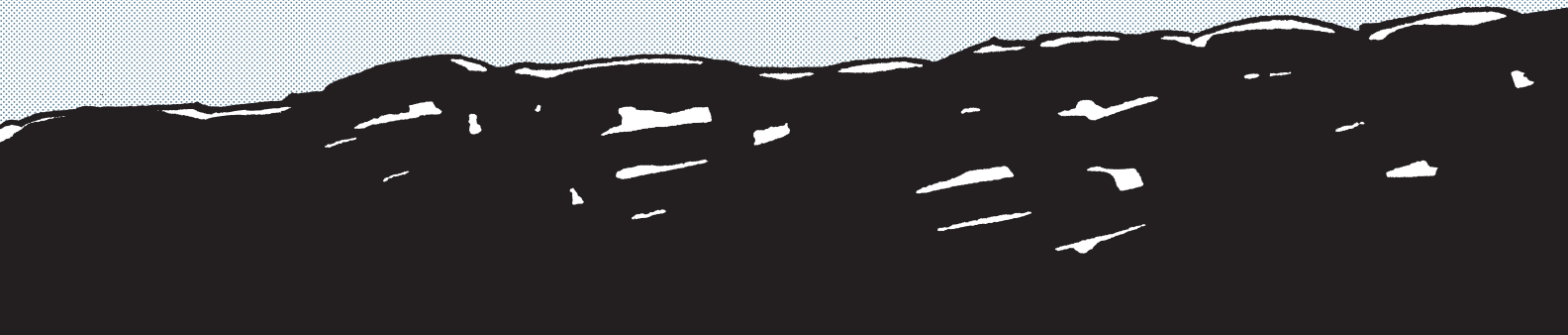



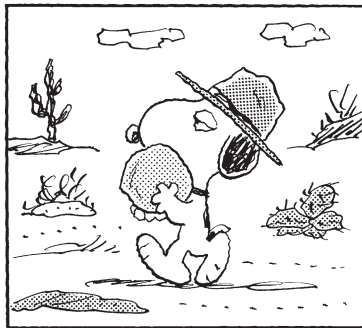

PEANUTS

by
SCHULZ

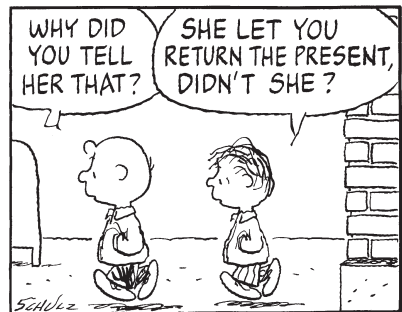
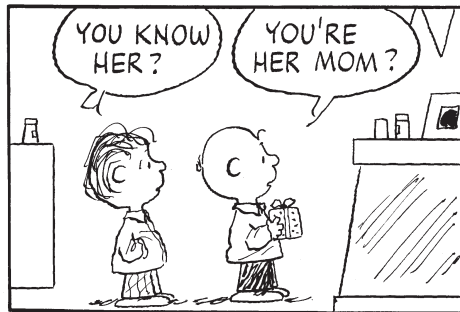
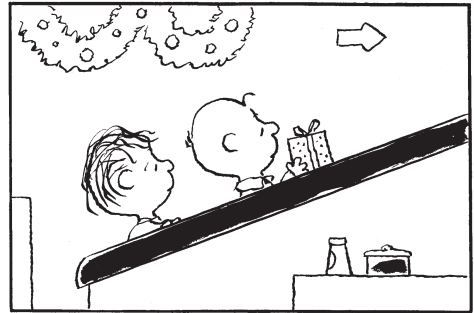

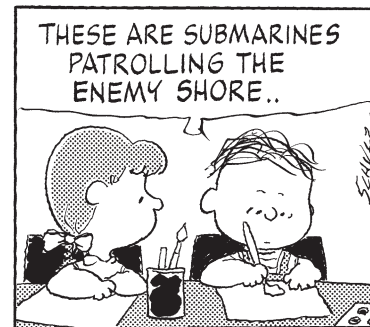
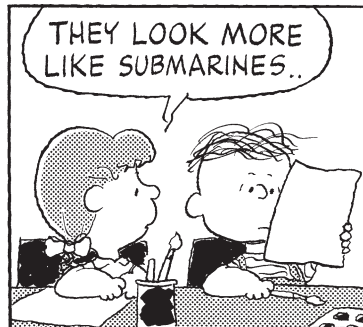
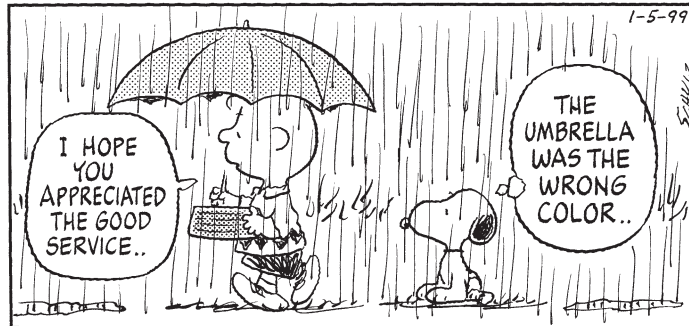
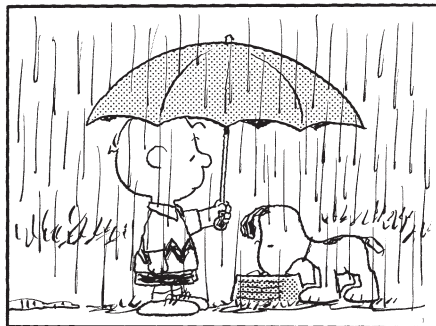
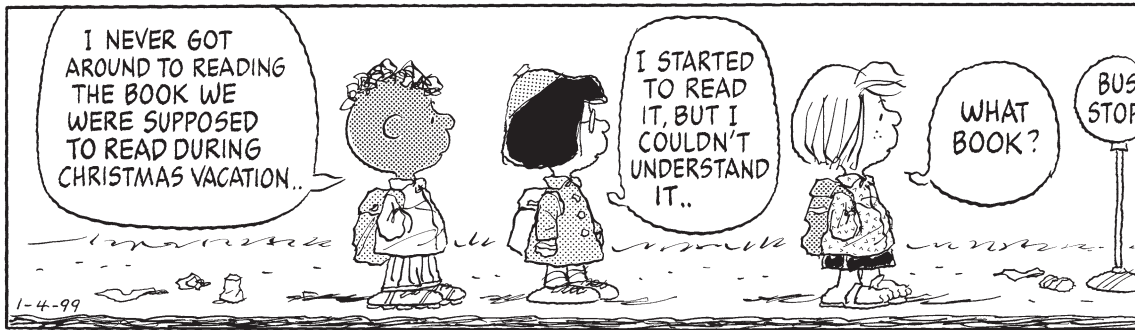

"What do dogs think about?" she wondered.

"Someday," thought the dog, "someone is going to leave the gate open, and I'll be out of here like a rocket."

1-7-99

"I suppose," she said, "all they think about is eating."

"Just don't stand too close to that gate," the dog chuckled.

Schulz

1-8-99

RATS! I THOUGHT THEY WERE GIVING AWAY FREE SOCCER BALLS..

Schulz

I SHOULD CHARGE YOU RENT FOR SHARING THIS BLANKET..

1-9-99

DOGS DON'T PAY RENT.. DOGS GUARD THE HOUSE

I WILL ADMIT, HOWEVER, THAT THERE'S A GOOD FEELING TO BE HAD FROM SHARING..

AND A GOOD FEELING THAT COMES FROM KNOWING YOU'RE GUARDING THE HOUSE..

WOOF!

Schulz

PEANUTS

by
SCHULZ

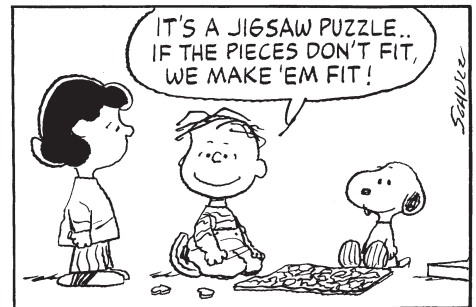
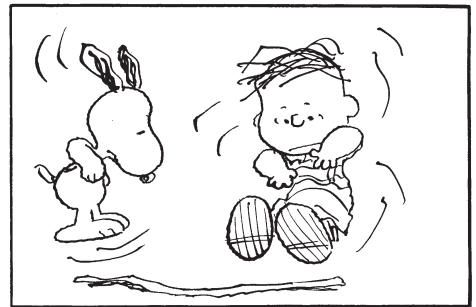
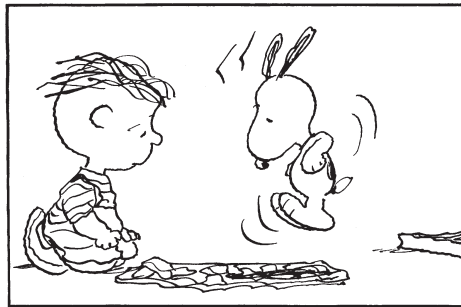
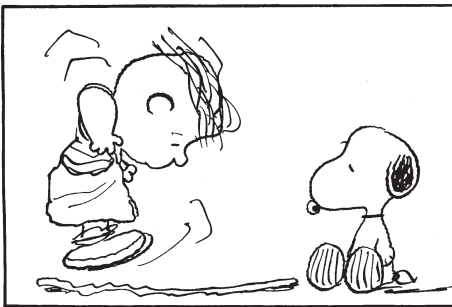

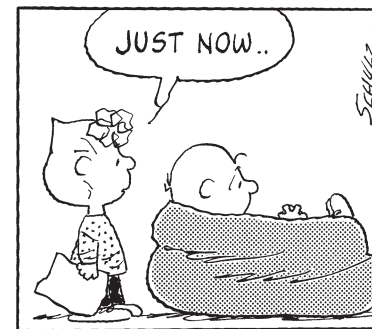
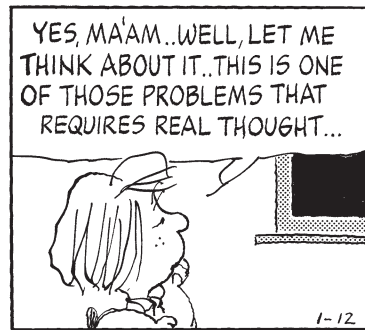
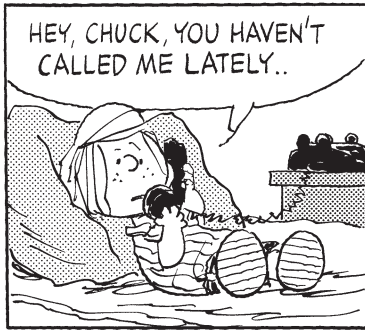

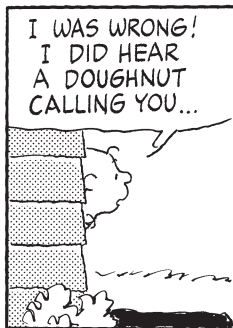
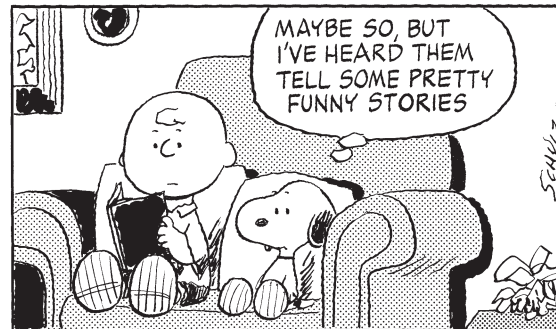
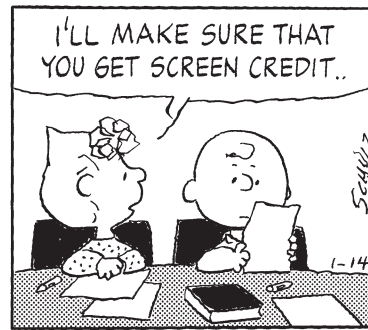
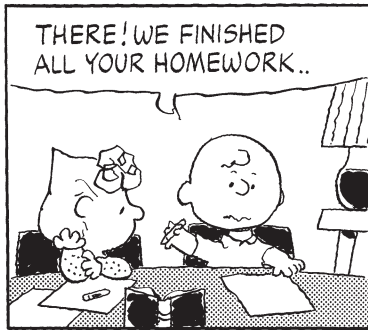

PEANUTS

by
SCHULZ

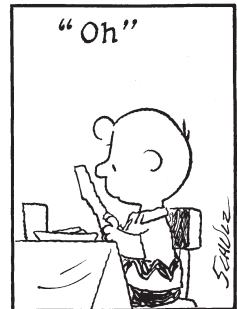
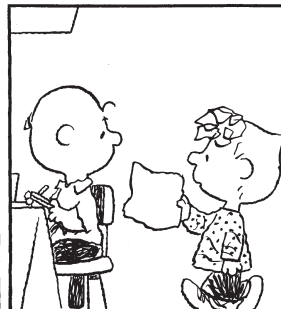
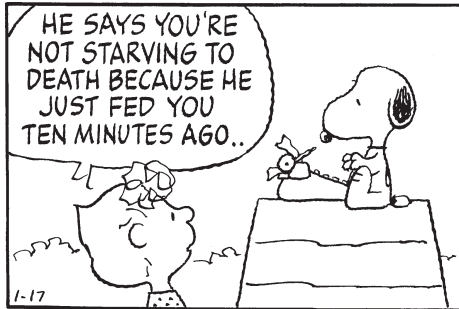
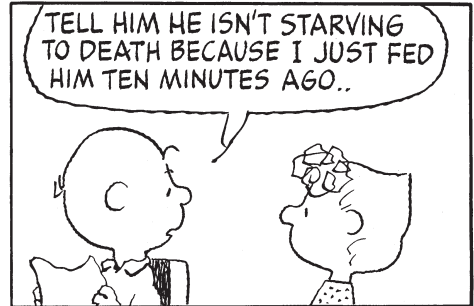

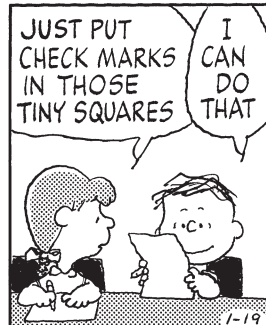

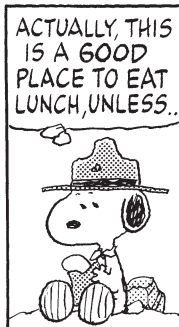
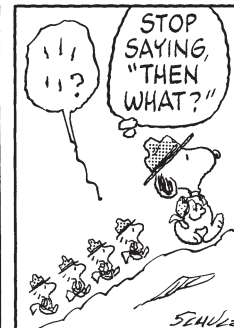
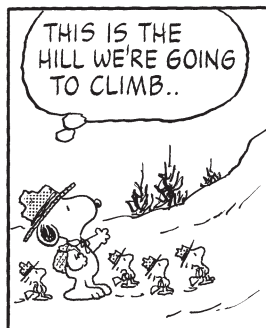
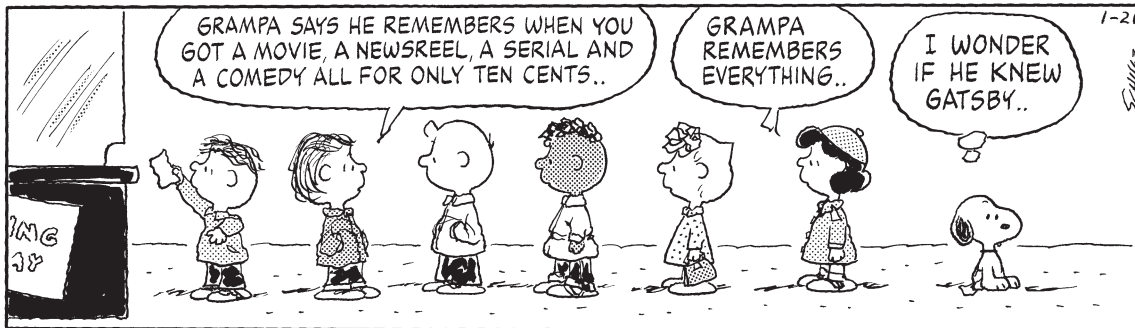

PEANUTS

by
SCHULZ



WHERE'S
THAT
PUPPY
DOG?



HERE,
PUPPY DOG..
JUMP OVER
THE STICK!

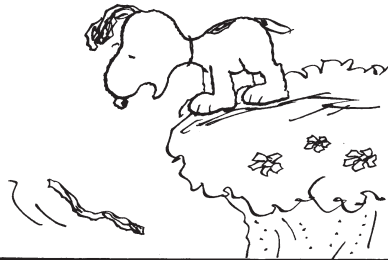
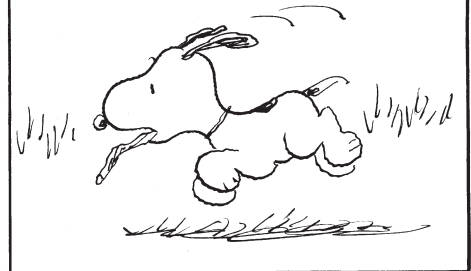
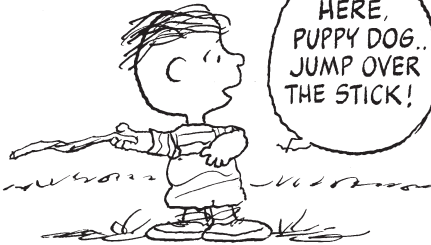

1-24

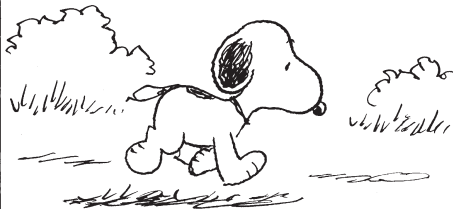

I AM NOT A
"PUPPY DOG"



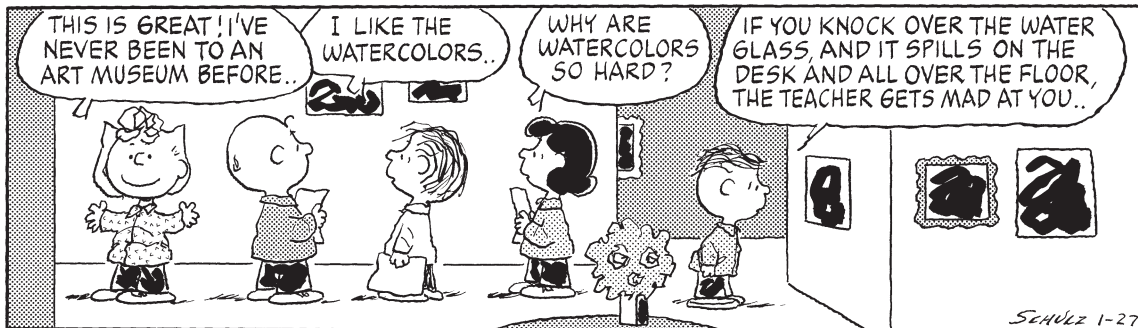
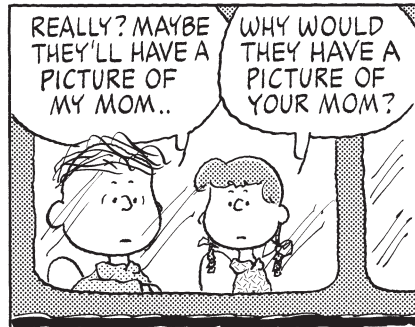

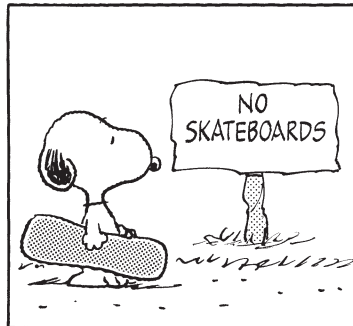
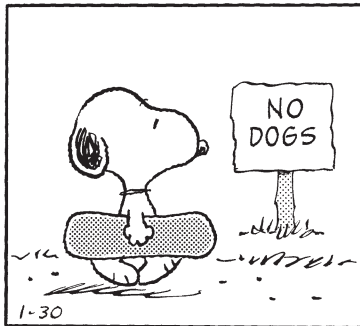
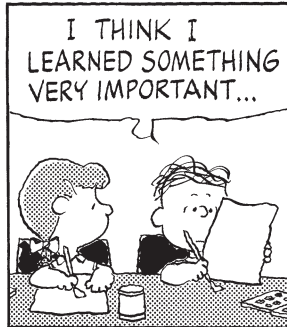
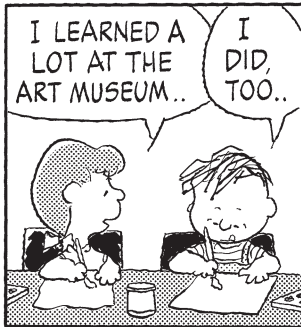
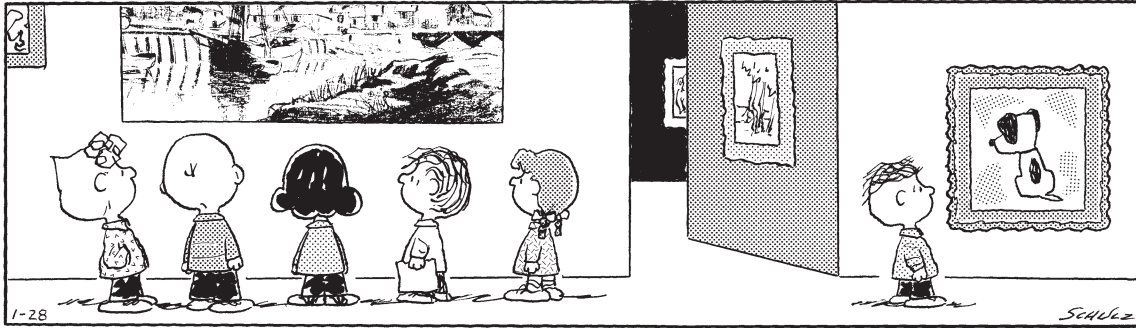

PEANUTS

by
SCHULZ

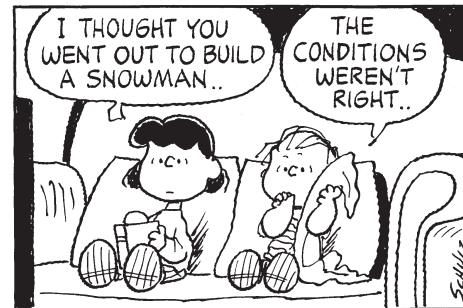
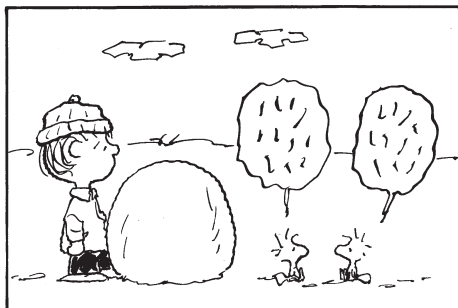
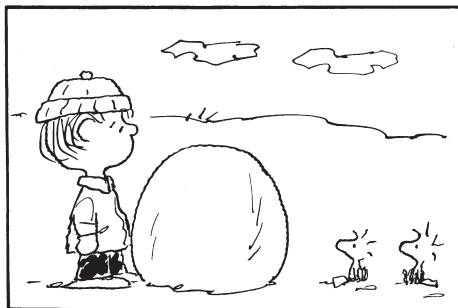
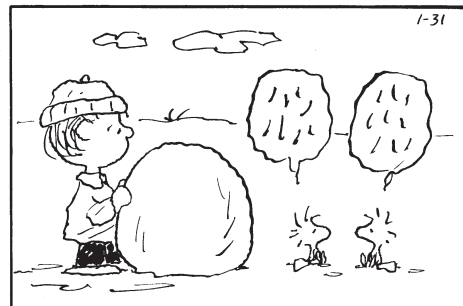
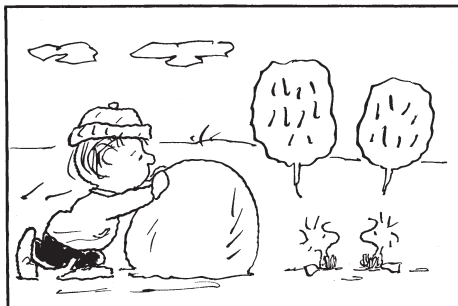
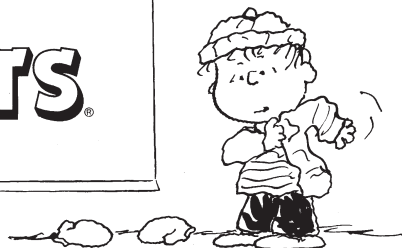

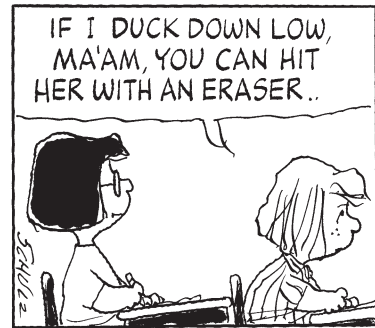
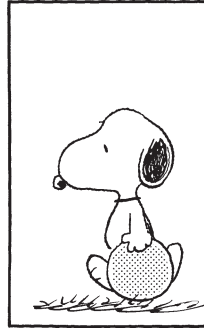

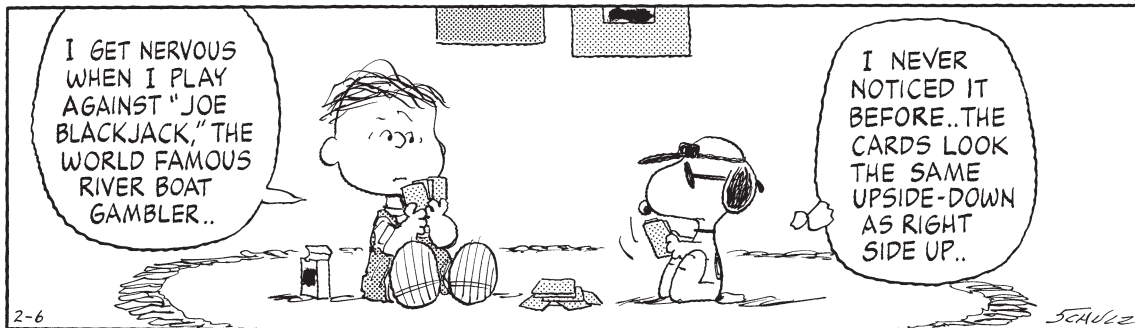

PEANUTS

by
SCHULZ



YES, MA'AM...AND
MAY I HAVE IT
GIFT WRAPPED?



YOU LOOK PROUD OF YOURSELF..
DID YOU JUST BUY SOMETHING?



IT'S A GLOBE..I THOUGHT I'D
GIVE IT TO THE LITTLE RED-HAIRED
GIRL FOR VALENTINE'S DAY..



WHEN YOU TURN
IT UPSIDE DOWN,
IT SNOWS..

IT
SNOWS?

2-7

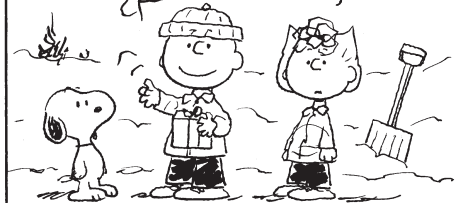

I DON'T UNDERSTAND..

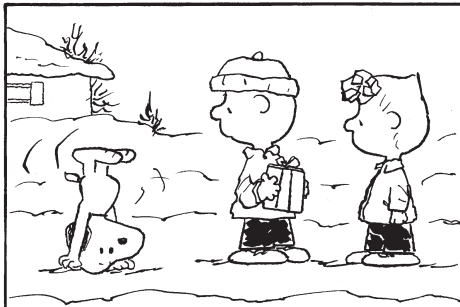

SOMETHING
LIKE THAT..



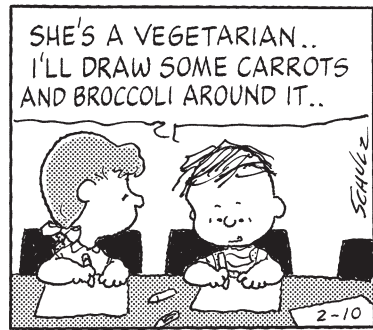
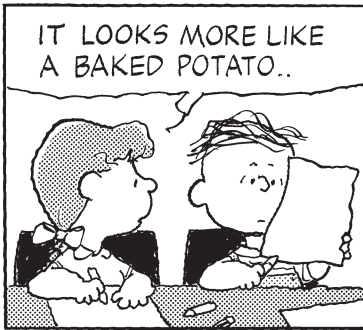
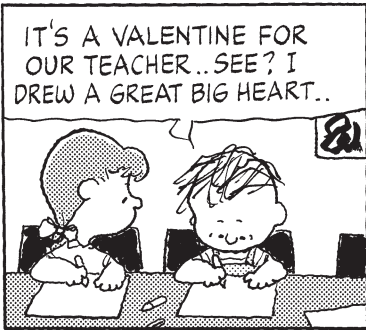
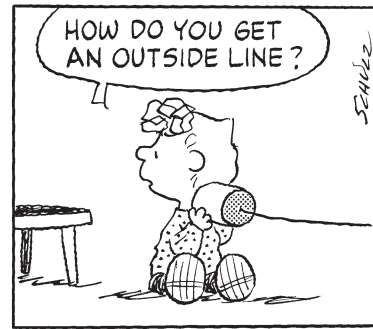
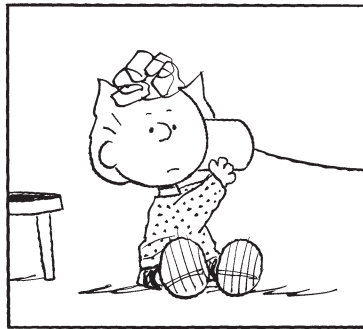
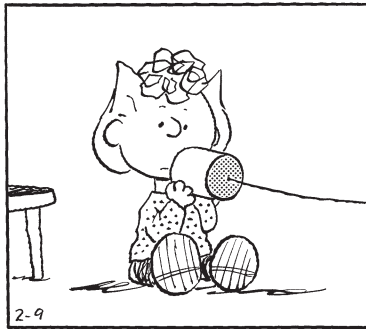
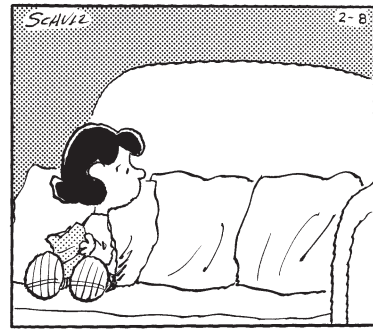

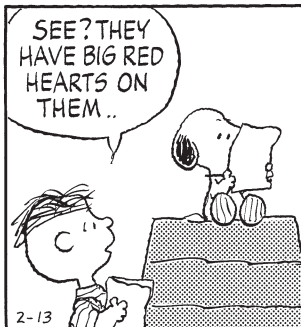
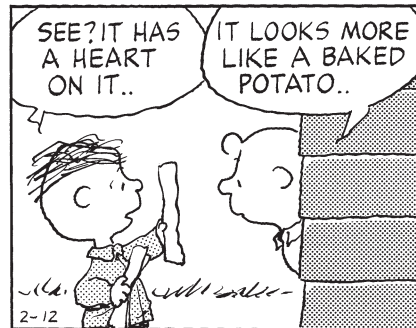

PEANUTS

by
SCHULZ

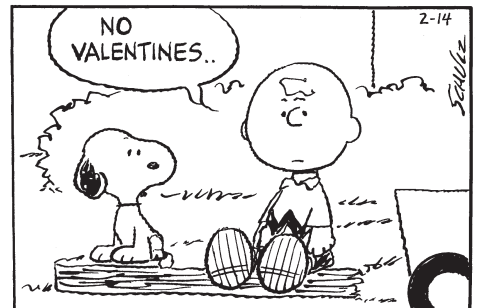
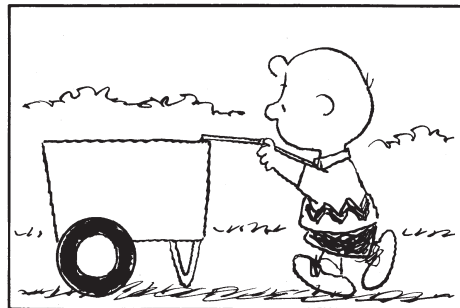
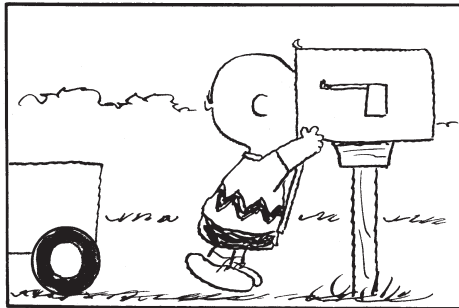
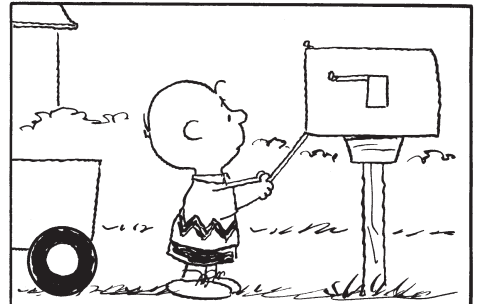
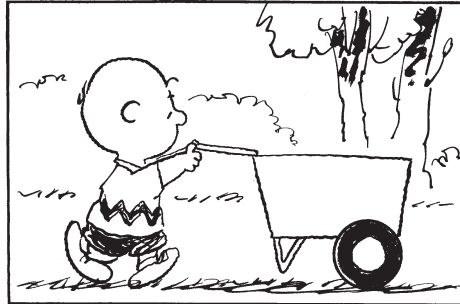
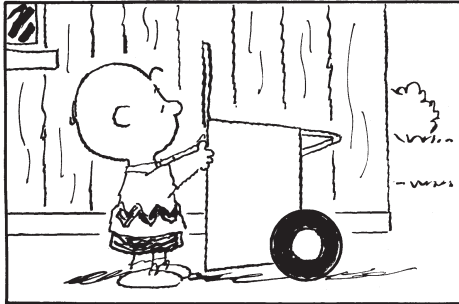
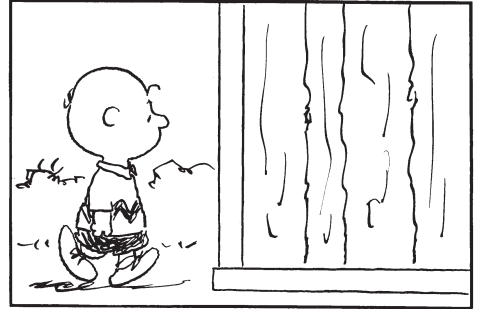
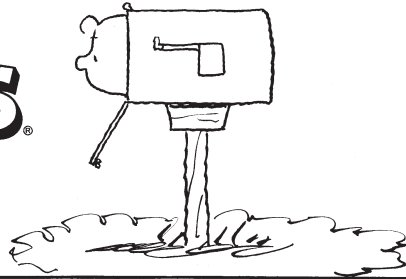

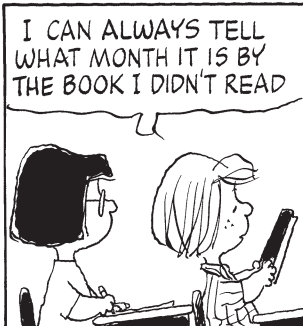
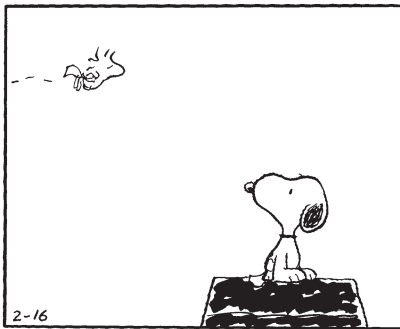

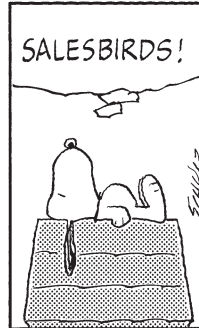
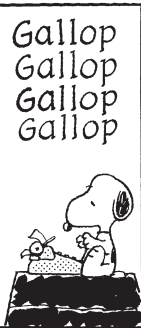
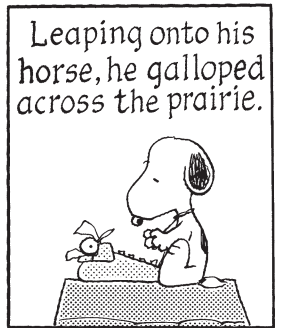
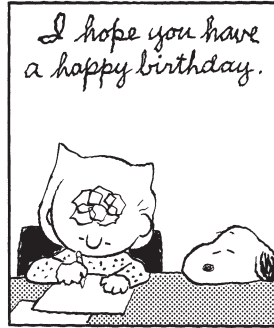
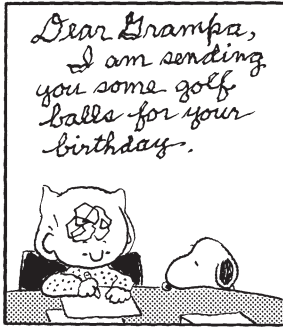

PEANUTS

by
Schulz

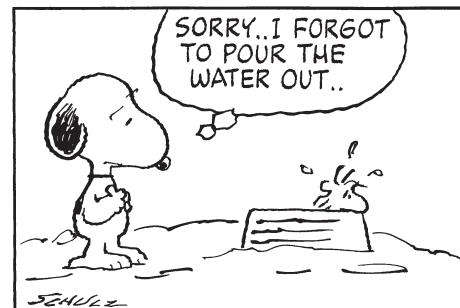
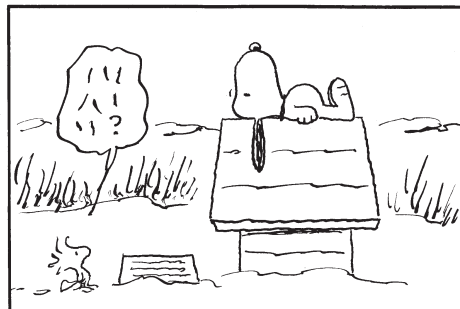
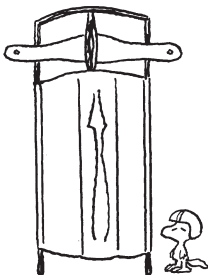

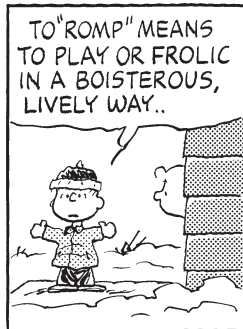
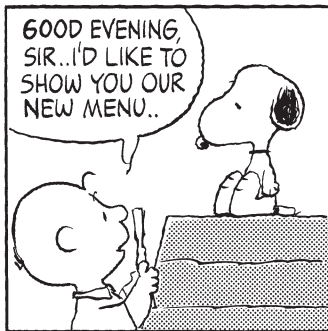
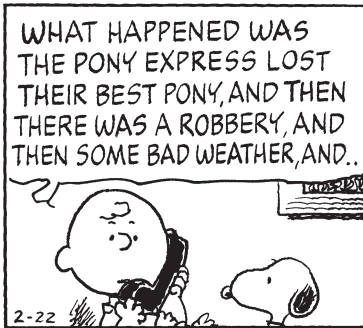
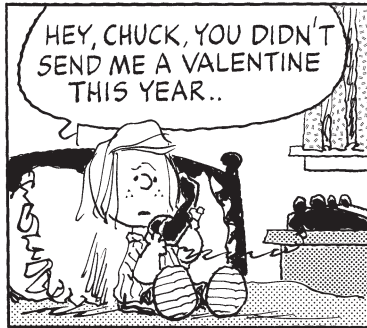

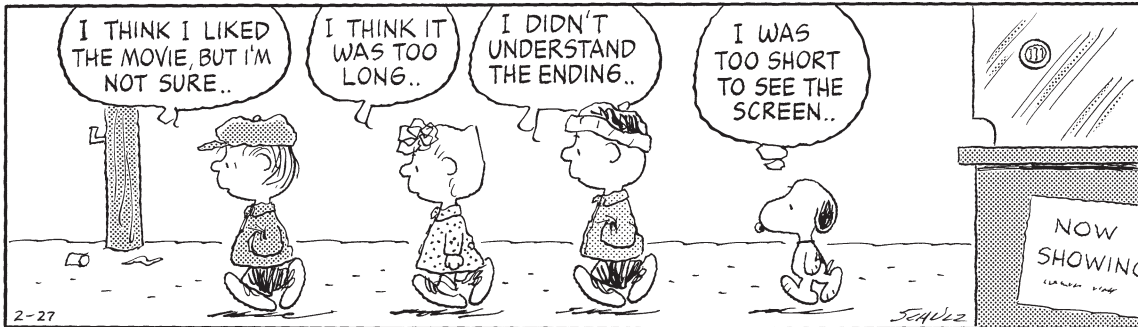

PEANUTS

by
SCHULZ

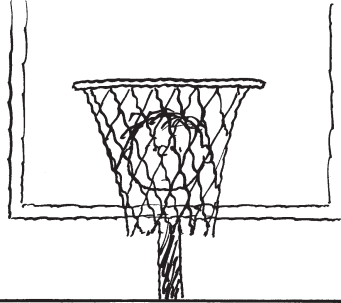

TEN SECONDS ON THE GAME CLOCK..
RERUN COMES OFF THE BENCH..



I BLOCK THE PASS! THE BALL IS MINE!



I WHIRL..



I DRIBBLE DOWN THE SIDE! WE'RE ONE POINT BEHIND..



I FAKE A PASS, AND WHIRL AGAIN..



THREE SECONDS ON THE GAME CLOCK..



2-28

I SHOOT..



IT'S IN!!



THEY LET ME HAVE THE GAME BALL..



SCHULZ

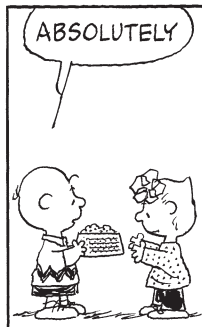
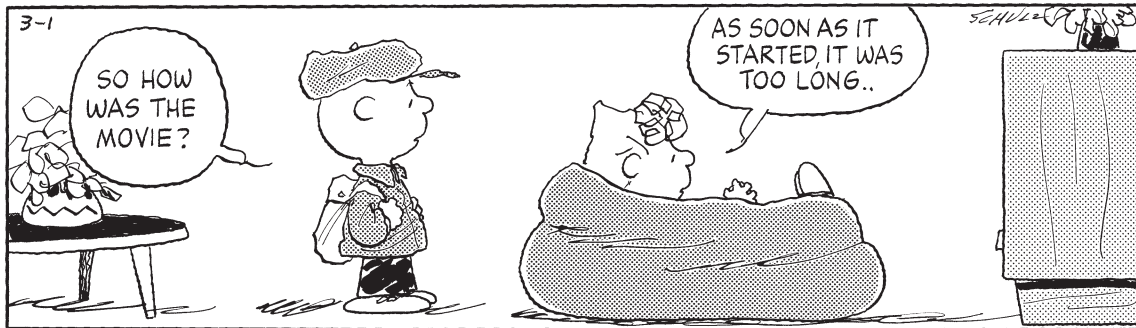

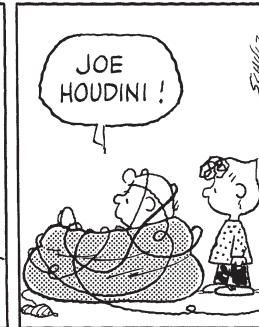
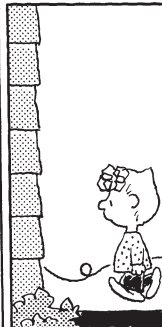
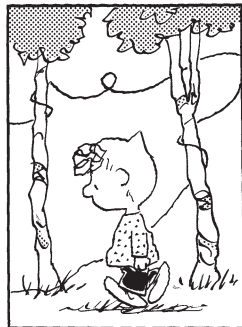
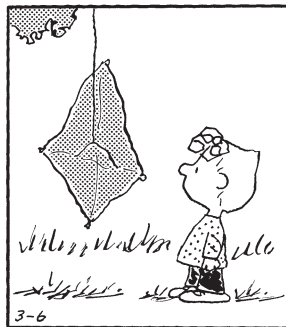
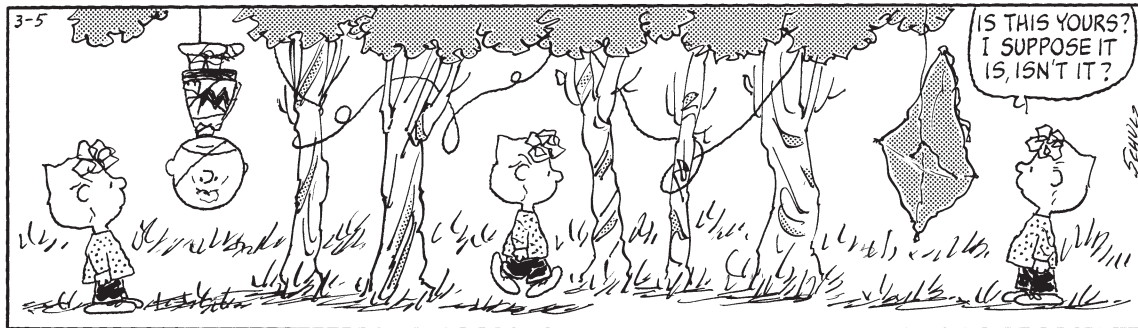
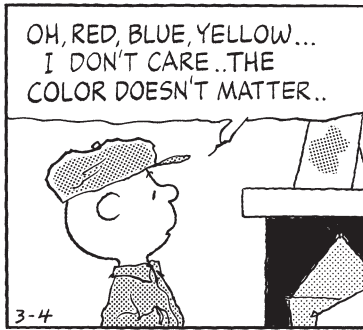

PEANUTS

by
SCHAULZ

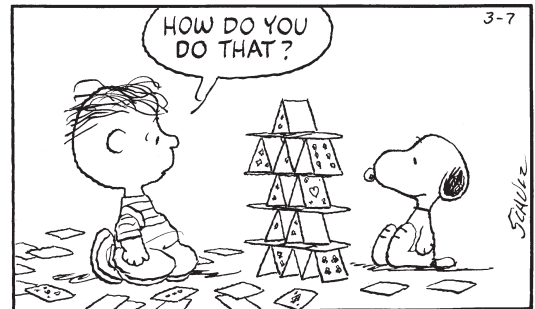
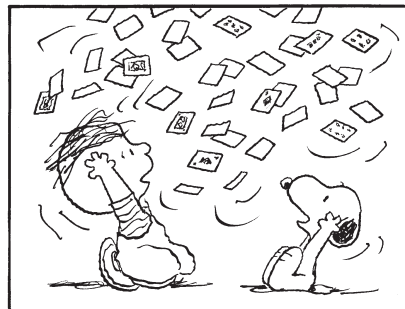
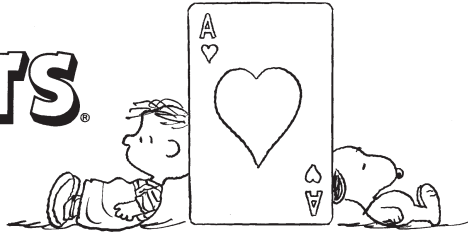

SOMETIMES I LIE AWAKE AT NIGHT, AND I ASK, "IS LIFE A MULTIPLE CHOICE TEST OR IS IT A TRUE OR FALSE TEST?"

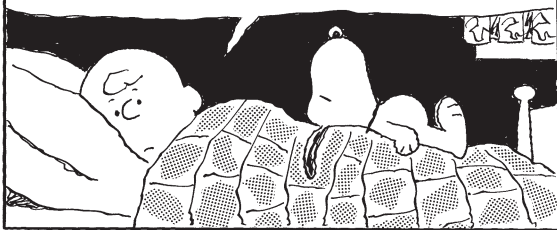

THEN A VOICE COMES TO ME OUT OF THE DARK, AND SAYS, "WE HATE TO TELL YOU THIS, BUT LIFE IS A THOUSAND WORD ESSAY"

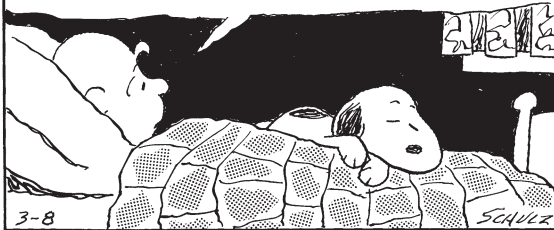

I CAN'T BELIEVE IT! HE SAID, "THAT'S ALL THE TIME WE HAVE LEFT.." WHAT'S HE TALKING ABOUT? I'VE GOT PLENTY OF TIME!



HOW CAN HE SAY, "THAT'S ALL THE TIME WE HAVE LEFT"? I'VE GOT MY WHOLE LIFE AHEAD OF ME!



MAYBE YOU SHOULD WRITE HIM A LETTER, AND TELL HIM HOW YOU FEEL..

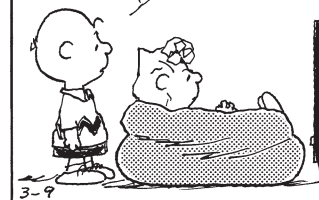

I DON'T HAVE TIME..



AFTER I HIT SEVENTY-ONE HOME RUNS, I'LL SELL THE BALL FOR THREE MILLION DOLLARS



HOW DOES THE WORST PLAYER IN THE HISTORY OF THE GAME EXPECT TO HIT SEVENTY-ONE HOME RUNS?



I'VE NEVER SEEN A SKY LOOK QUITE SO BLUE, HAVE YOU?



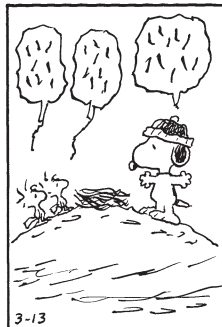
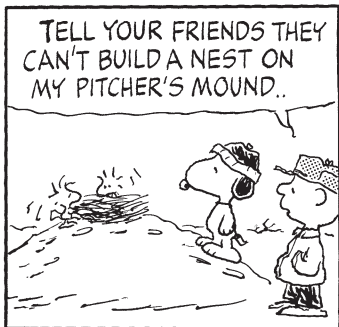
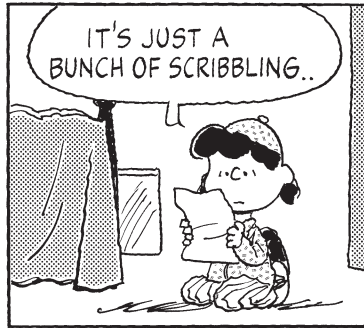
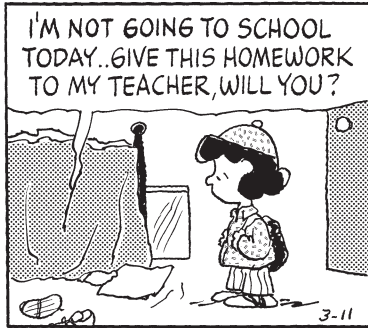

PEANUTS

by
SCHULZ

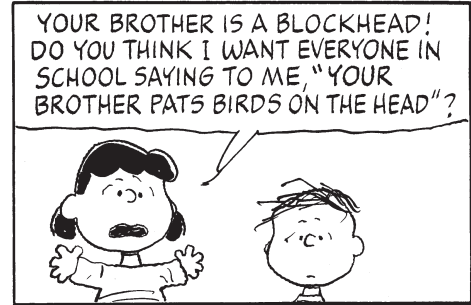
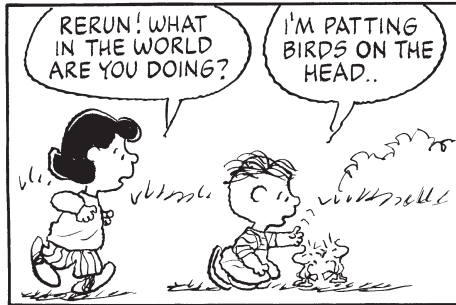

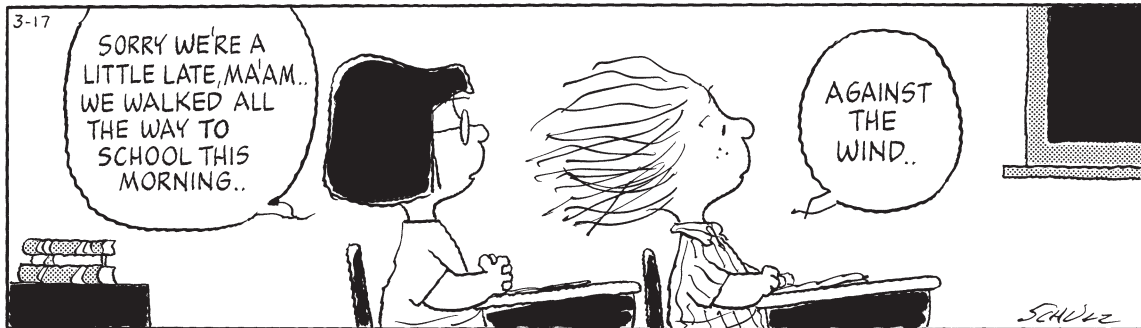
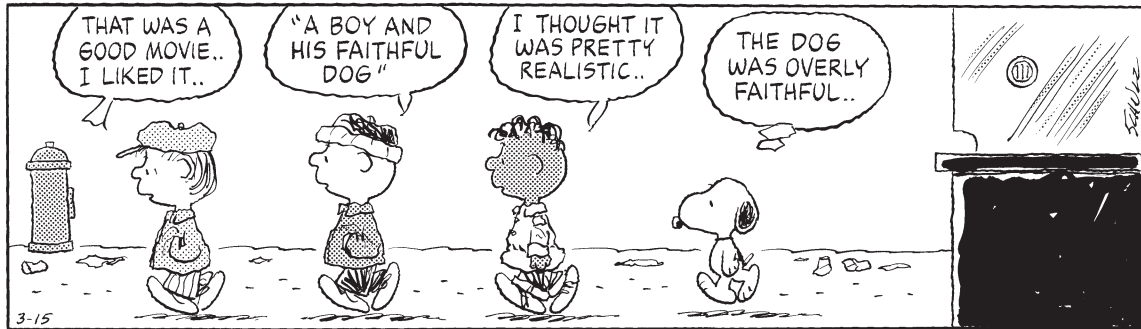

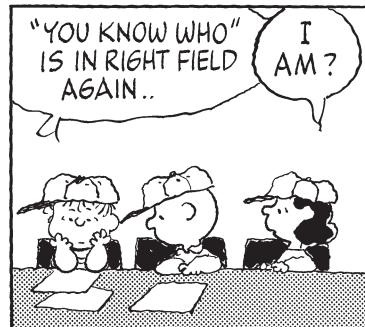
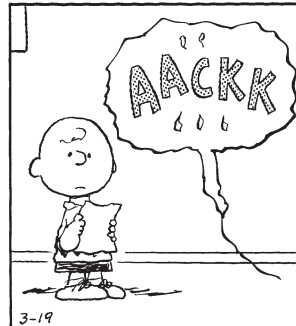
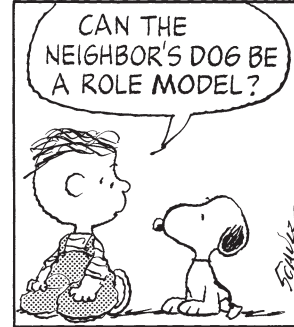
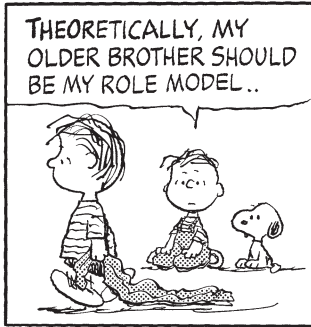

PEANUTS

by
SCHULZ

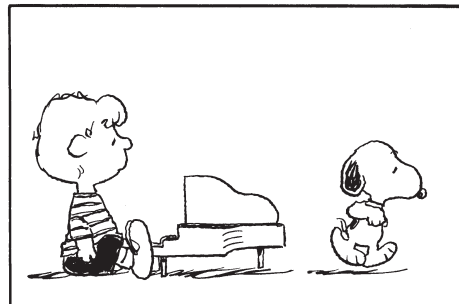
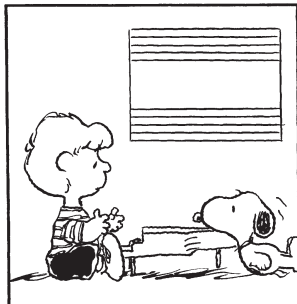
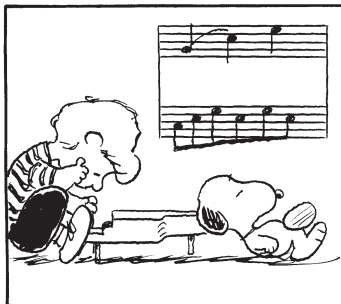
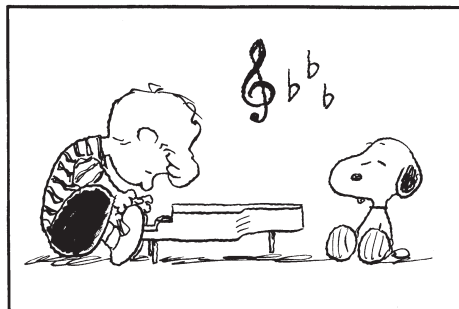
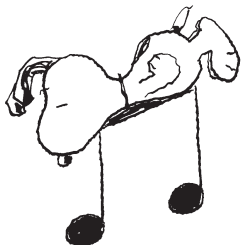

3-21

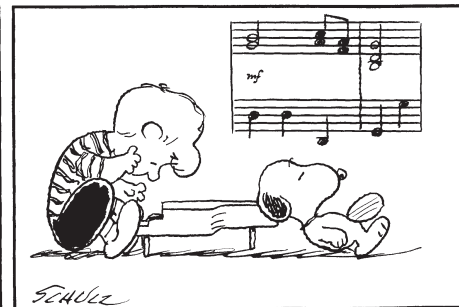
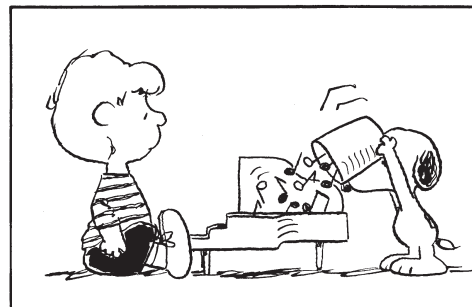

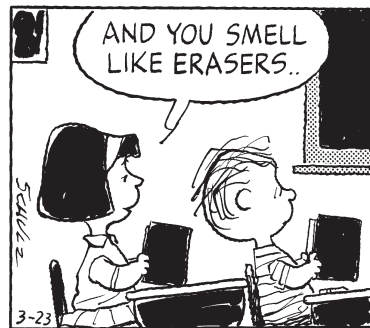
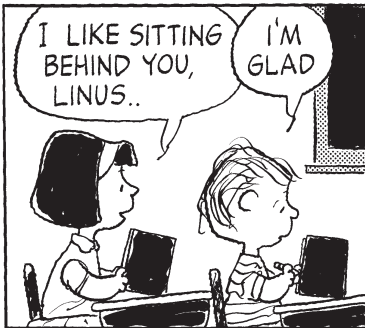
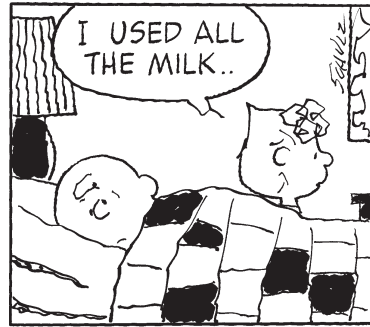
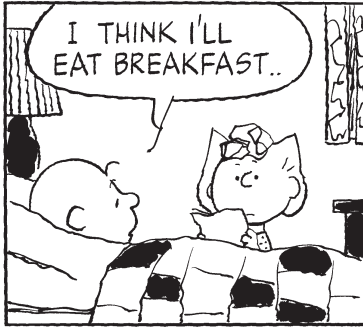
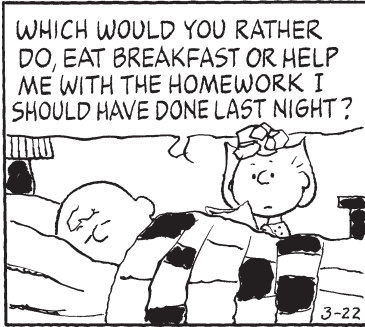

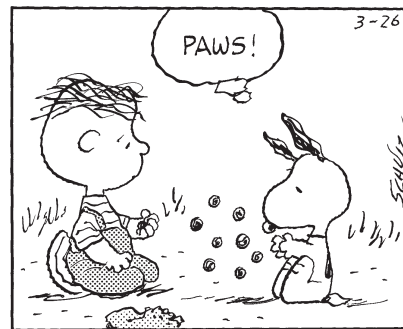

PEANUTS®

by
SCHULZ

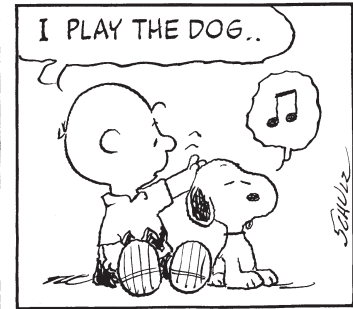
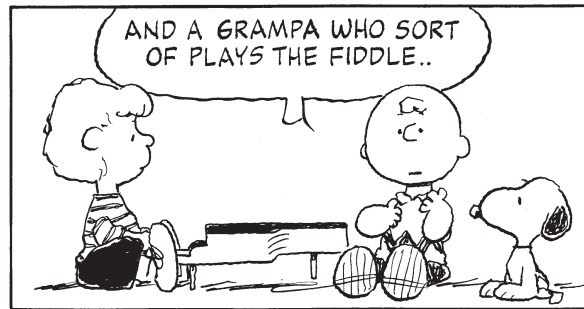
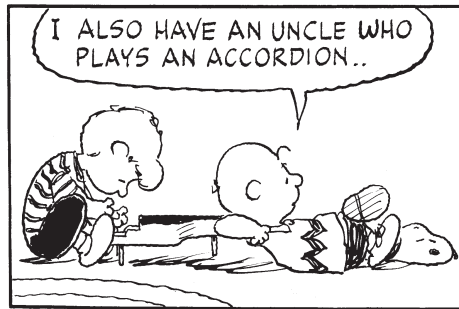
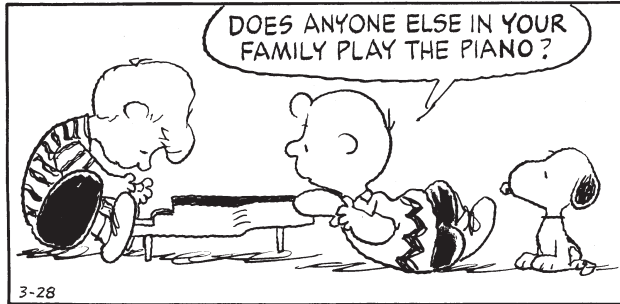
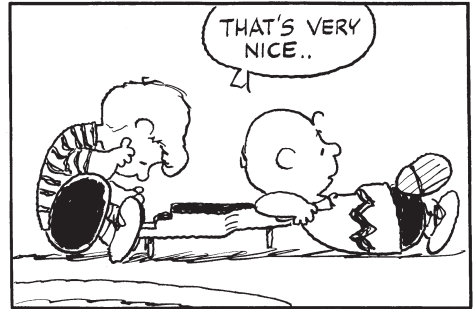
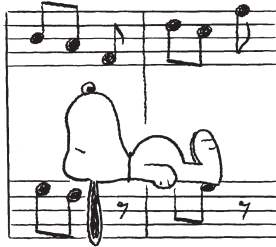

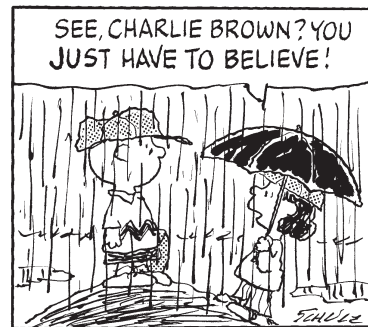
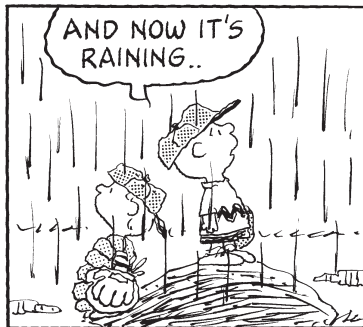
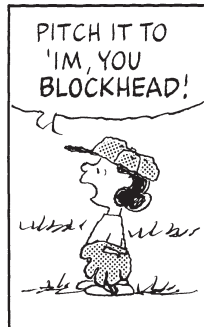
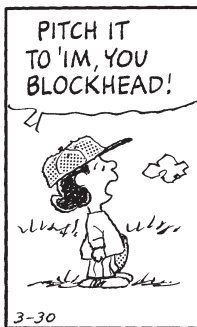
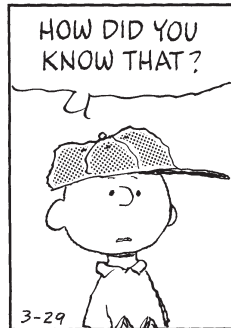
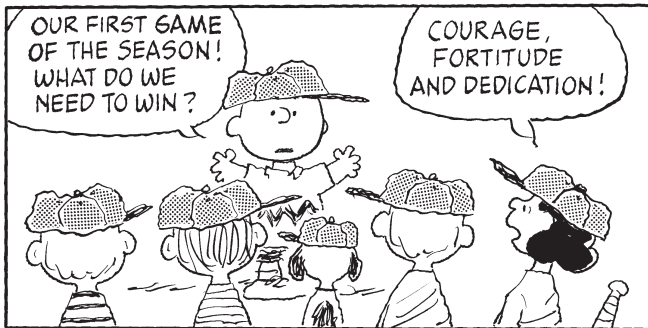



PEANUTS

by
SCHULZ

WE CAN CHANGE
YOUR LIFE...
SORT OF..

I DON'T ALWAYS
WANT TO BE THE
WAY I AM..

PSYCHIATRIC
HELP 54

SO I'M WONDERING,
COULD I EVER
LEARN TO BE THE
LIFE OF THE
PARTY?

THE DOCTOR
IS IN

YOU?

HA HA HA HA HA!

THE DOCTOR
IS IN

I'M SORRY.. I SHOULDN'T
HAVE LAUGHED... WHERE
WERE WE? OH, YES, NOW
I REMEMBER..

YOU? THE
LIFE OF
THE PARTY?

HA HA HA HA!

THE DOCTOR
IS IN

WELL, HOW
DID YOUR
SESSION WITH
THE PSYCHIATRIST
GO?

I WAS ASKING
HER IF I COULD
EVER LEARN TO
BE THE LIFE OF
THE PARTY, AND..

YOU? HA HA HA HA!

ACTUALLY, I'VE NEVER
BEEN INVITED TO
A PARTY..

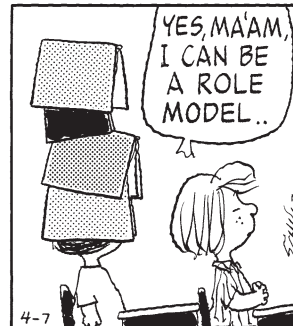
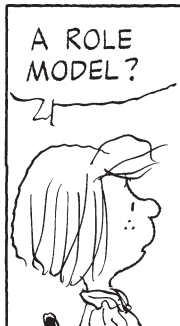
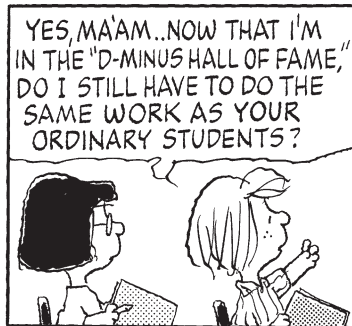

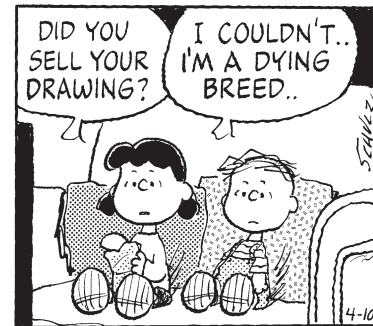
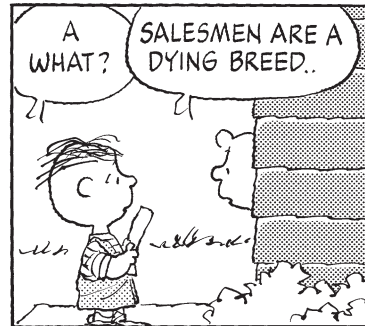
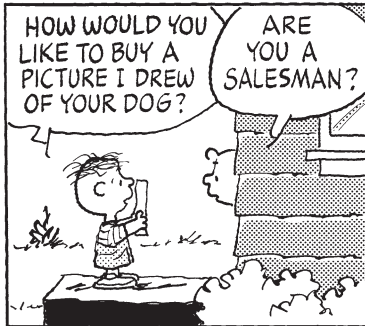
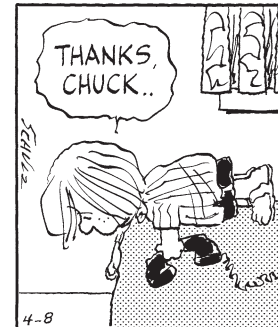
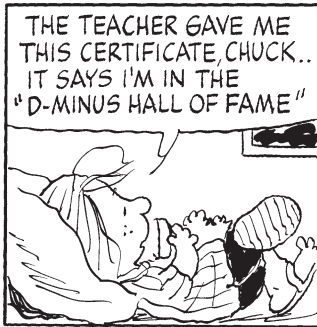

PEANUTS

by
SCHULZ



RERUN!
ARE YOU
COMING
OR NOT?

I'M
NOT!

I'M NEVER GOING
TO SCHOOL AGAIN..



THE TEACHER ASKED ME IF I THOUGHT
I'VE LEARNED EVERYTHING I NEED TO KNOW



I THINK SHE WAS
BEING SARCASTIC..



4-11

ANYWAY, I SAID, "YES".. NOW,
SHE'S MAD AT ME..



DO YOU THINK YOU'VE LEARNED
EVERYTHING YOU NEED TO KNOW?



I THINK I'VE LEARNED ALL I NEED
TO KNOW TO LIVE UNDER A BED..



SCHULZ

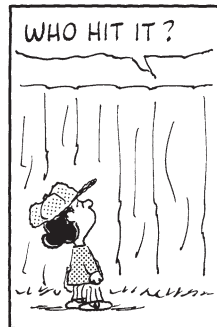



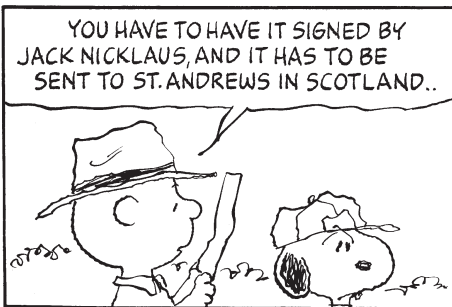
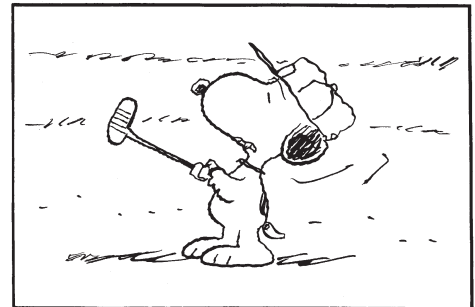
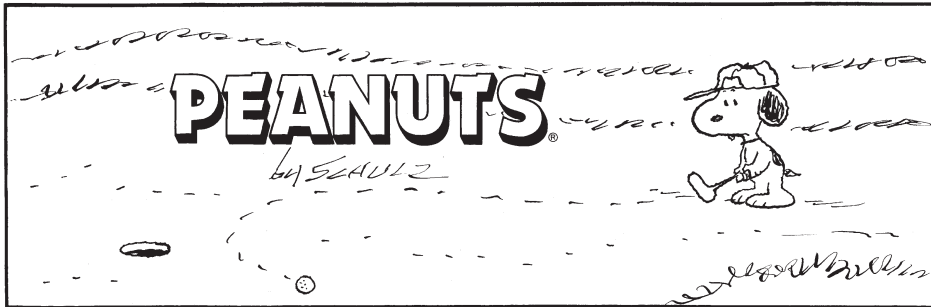

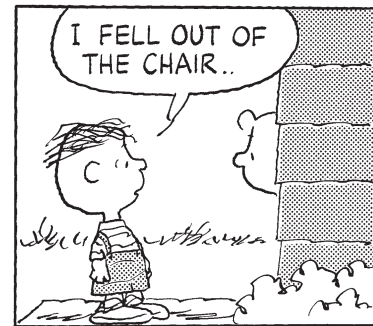
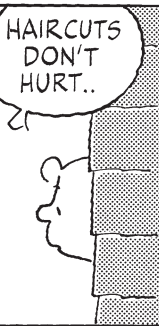
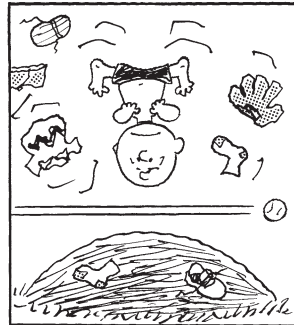
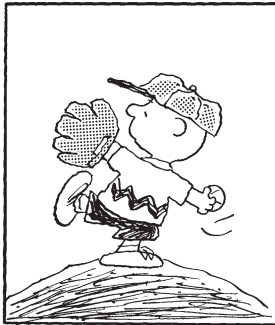

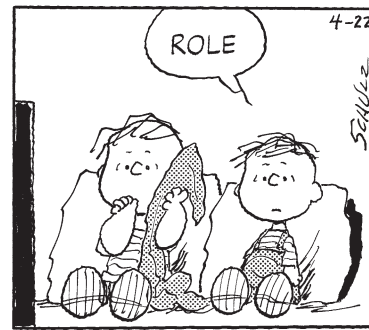

PEANUTS

by
SCHULZ

WHO AM
I? I
AM THE
MANAGER



OKAY,
LET'S GET
SOME
RUNS!



WHAT'S
THAT?



ICE WATER! WHEN WE WIN
THE CHAMPIONSHIP, WE'LL
POUR IT OVER OUR
MANAGER'S HEAD..

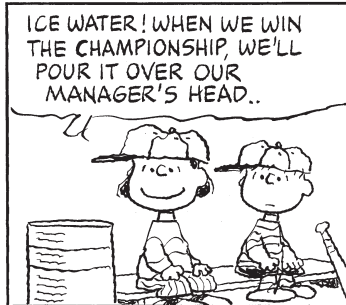

I'VE SEEN THEM
DO IT AT FOOTBALL
GAMES..

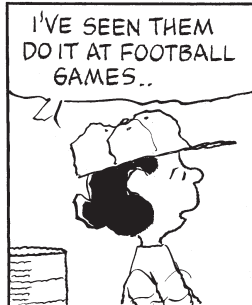

WE'RE NEVER GOING TO WIN
A CHAMPIONSHIP...WE CAN'T
EVEN WIN A GAME!



THAT'S ALL RIGHT..
BUT I CAN'T
WAIT FOREVER..

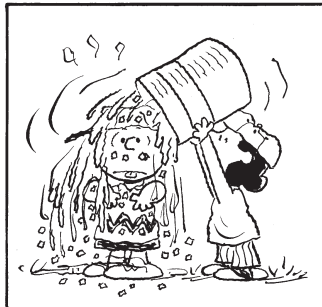

ARE YOU OUT OF YOUR MIND?!
CHARLIE BROWN IS GOING TO HATE
YOU FOR THE REST OF YOUR LIFE!

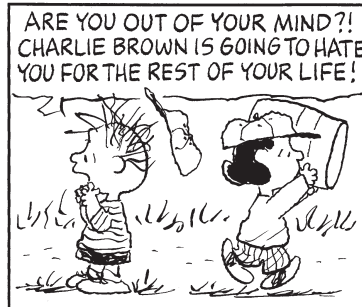

DID WE WIN?



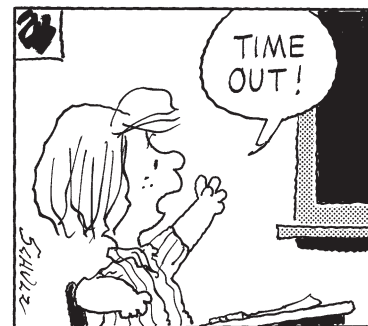
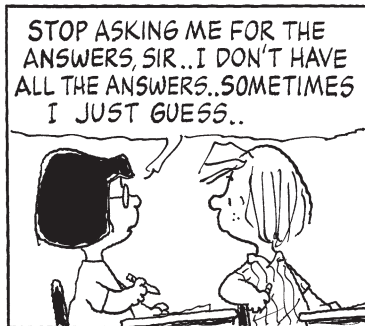
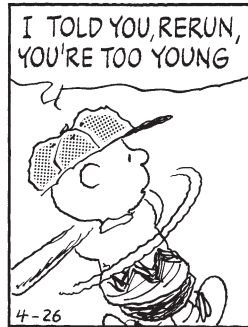

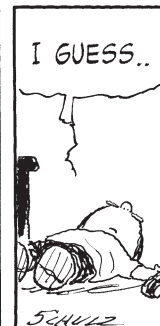
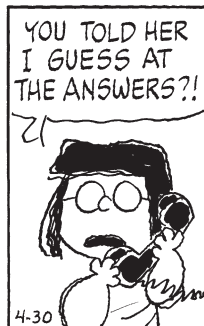
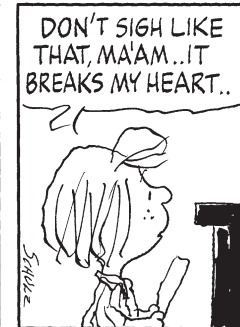
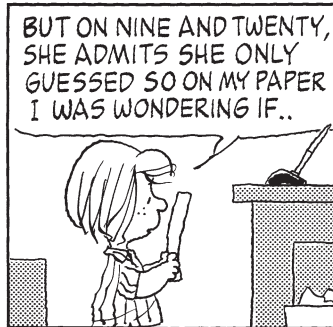
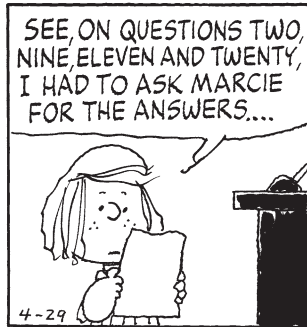

PEANUTS

by
SCHULZ

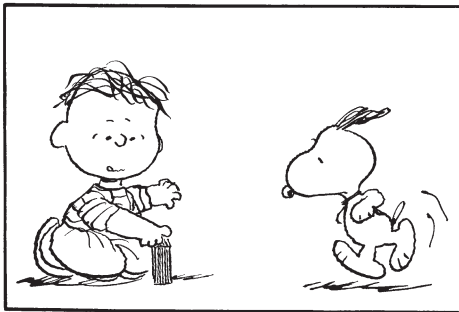
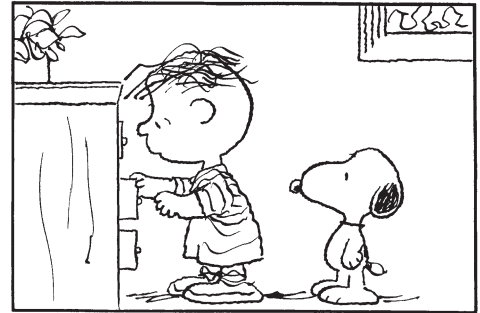
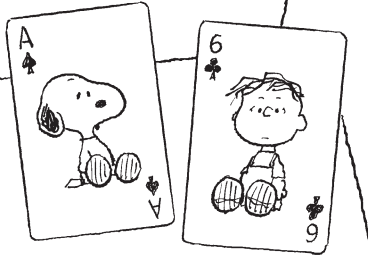

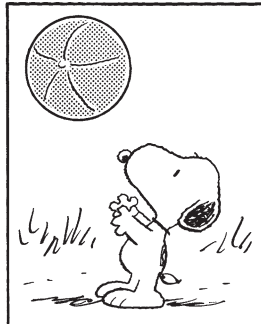
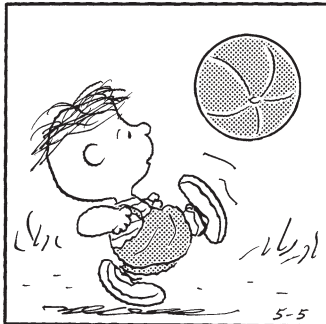
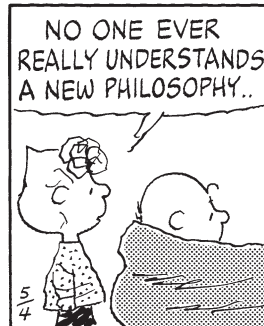
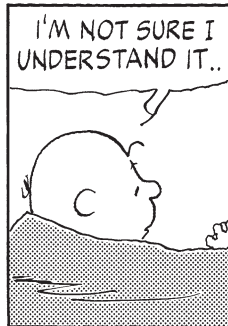

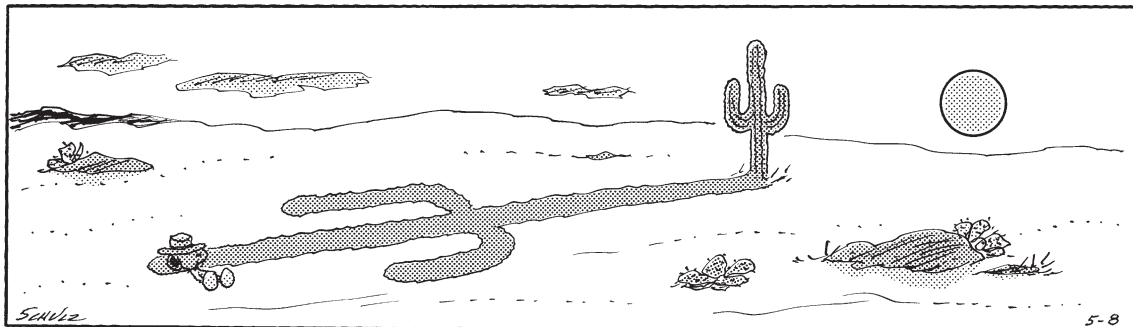
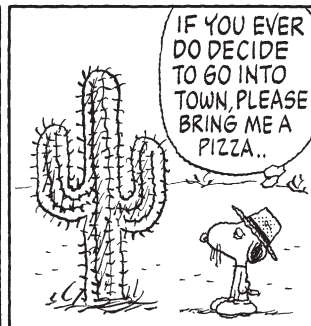
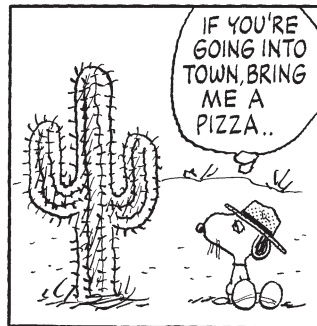
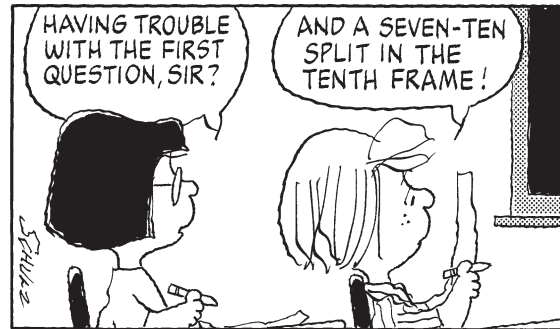

PEANUTS

by
SCHULZ

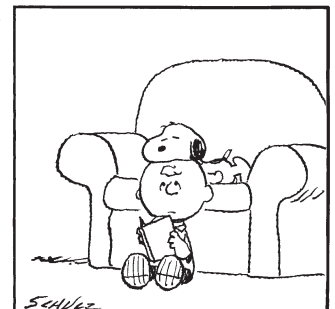
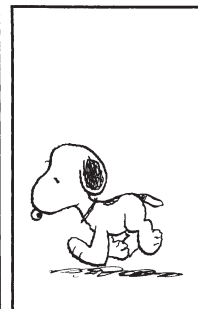
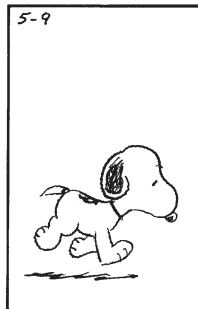
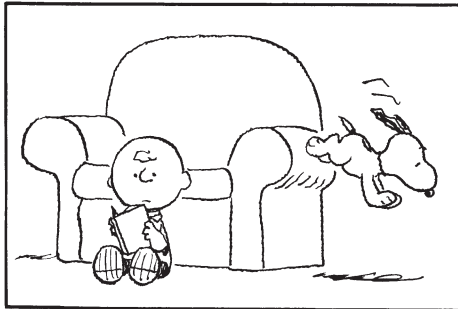
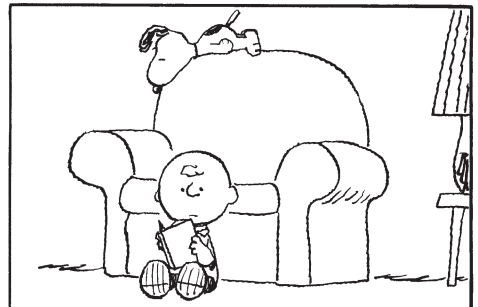
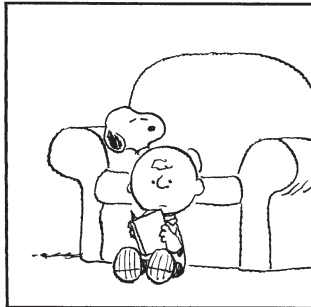
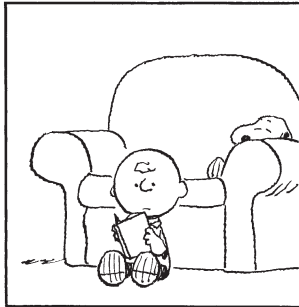
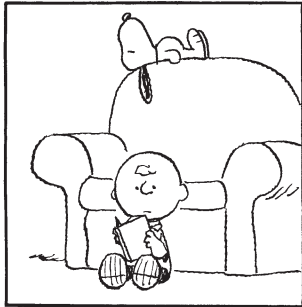
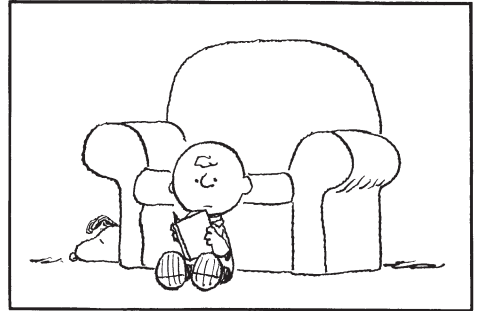
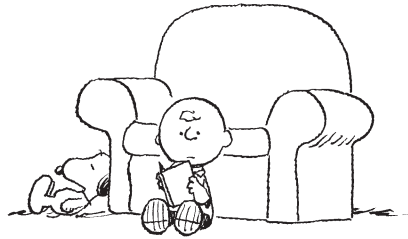

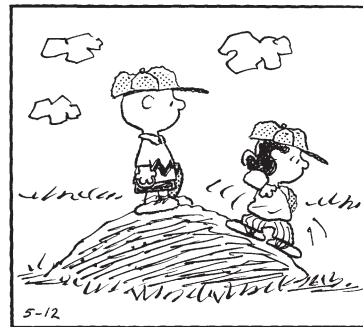
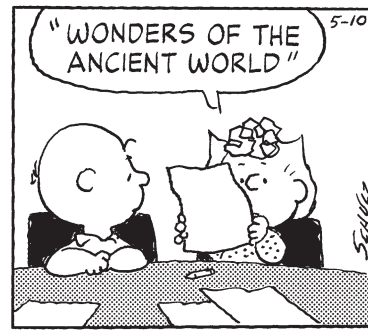
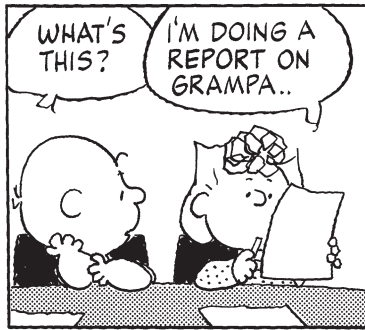

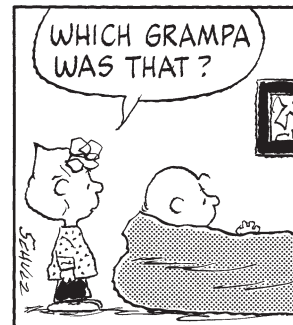
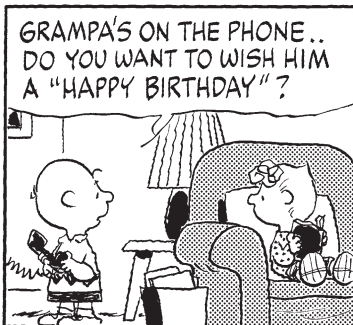
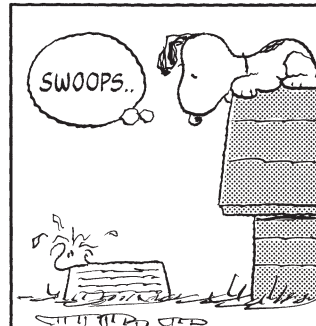
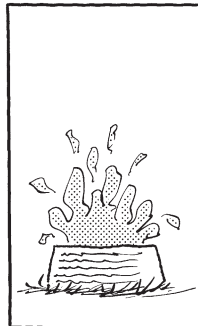
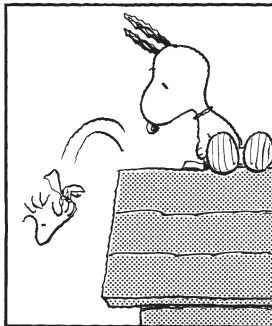

PEANUTS

by
SCHULZ

LINUS?

YOU DIDN'T
ANSWER...

ANSWER
WHAT?

HERE'S WHAT I WANTED
TO ASK YOU..

YAWN

WHAT? I'M SORRY..I WAS YAWNING AND
STRETCHING..I CAN'T HEAR WHEN I'M
YAWNING AND STRETCHING..

WELL, I WAS ASKING
YOU IF..

I COULDN'T HEAR YOU..I WAS
CHEWING POTATO CHIPS..WHEN I CHEW
POTATO CHIPS, I CAN'T HEAR ANYTHING

ALL RIGHT, IF
YOU CAN'T HEAR
ME, I'LL WRITE
IT DOWN..

I CAN'T READ THIS..IT'S
DARK IN HERE..

5-16

SCHULZ

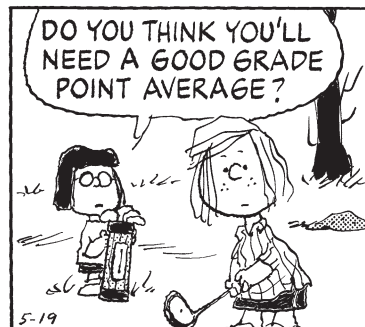
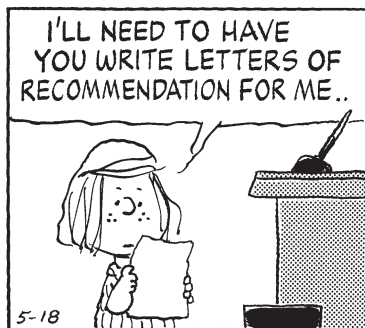
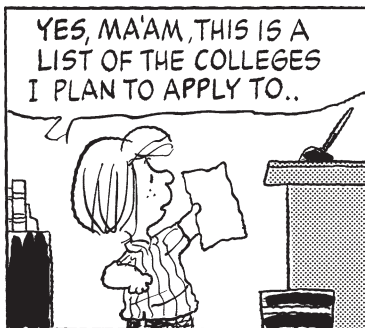
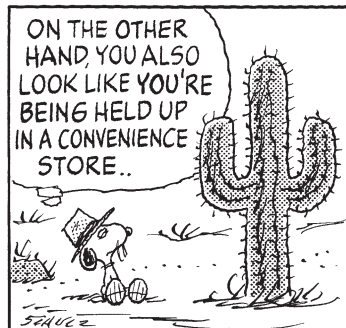
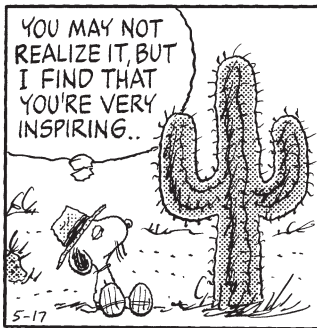

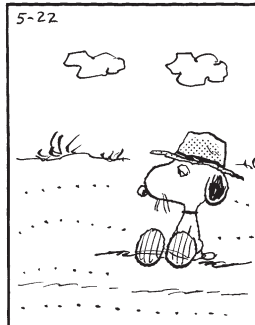
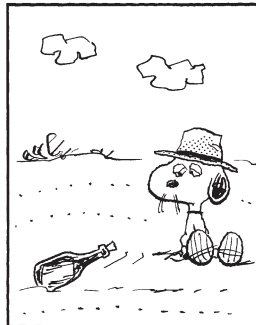
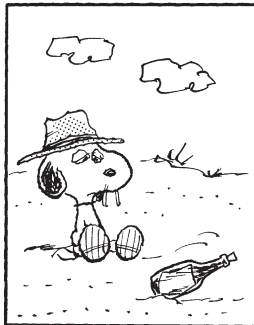
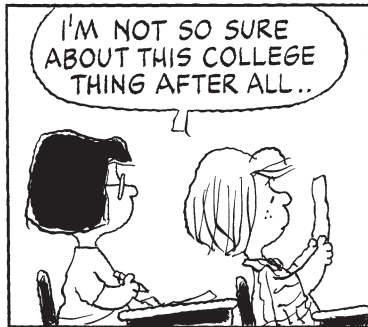

PEANUTS

OUI, MON
CAPITAINE!

BUT WHERE
WILL I GET
THE MEN?

ASK YOUR DOG
IF HE WANTS TO
COME OUT
AND PLAY..

ASK HIM
YOURSELF..
HERE HE
COMES NOW..

BONJOUR,
MONSIEUR..

ODD
LOOKING
FELLOW..

PROBABLY SAW ONE OF OUR NEW
RECRUITING POSTERS...

5-23

I CAN'T BELIEVE WHAT
HEADQUARTERS IS SENDING
US THESE DAYS..

HERE, PUT
THIS ON..

TELL MOM I THINK I
MAY BE GONE FOR
FIVE YEARS..

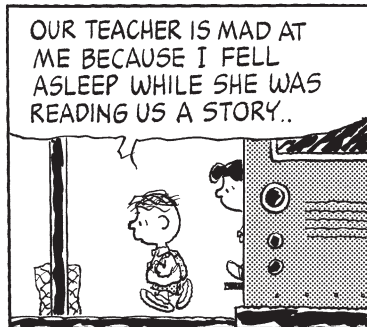
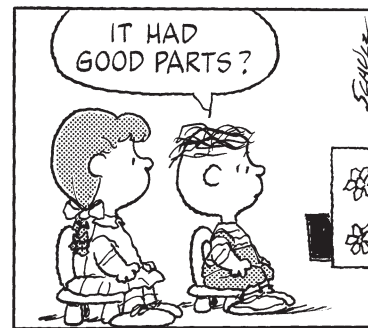
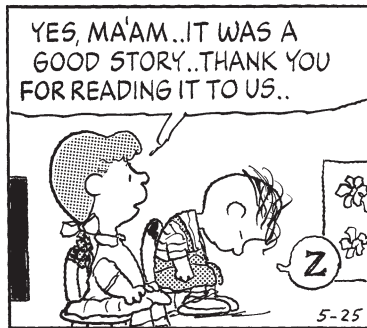
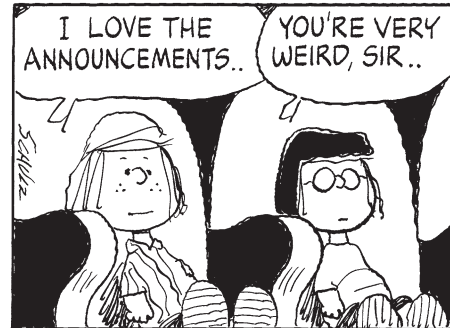
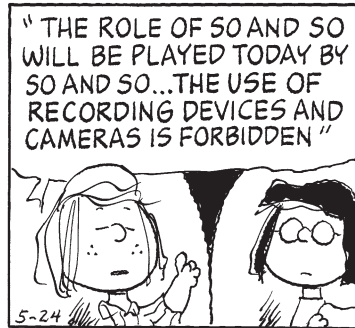

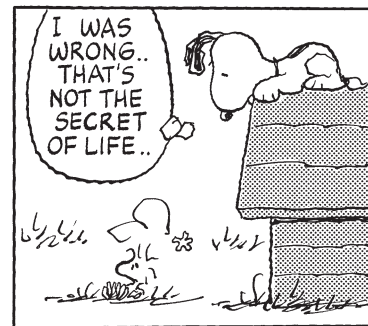
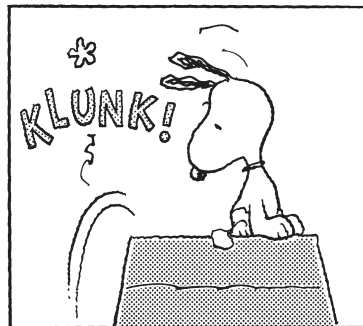
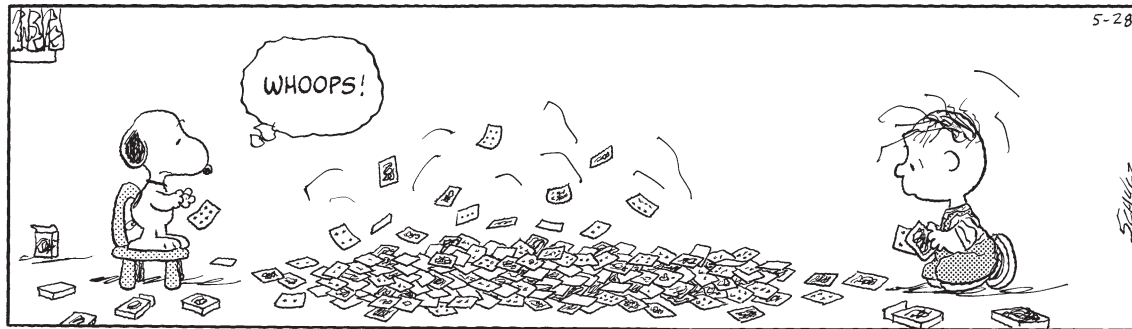
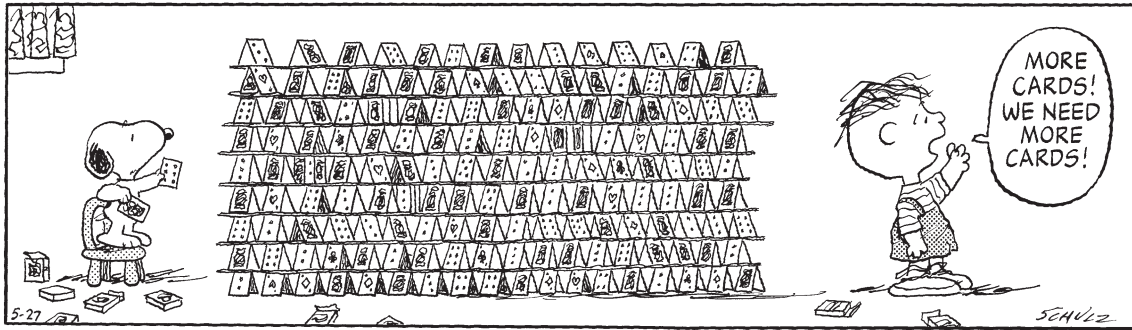

PEANUTS

by
SCHULZ

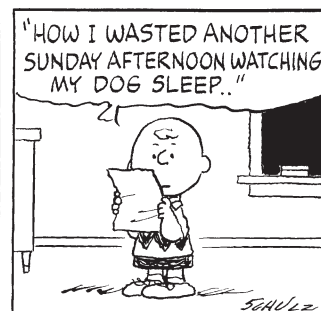
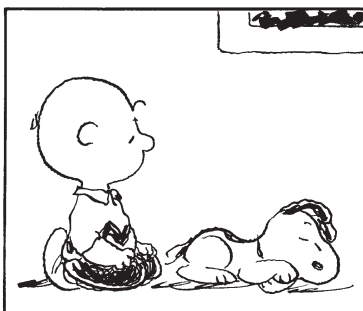
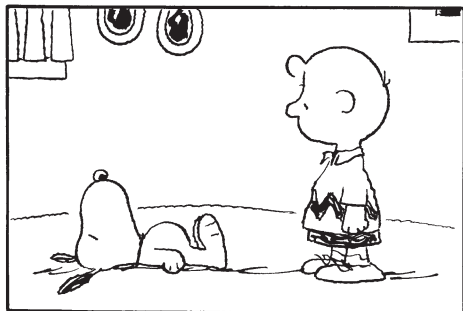
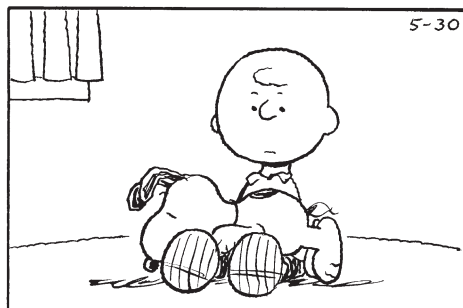
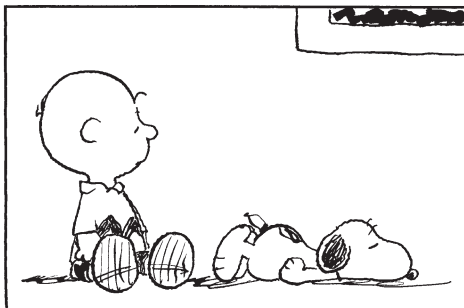
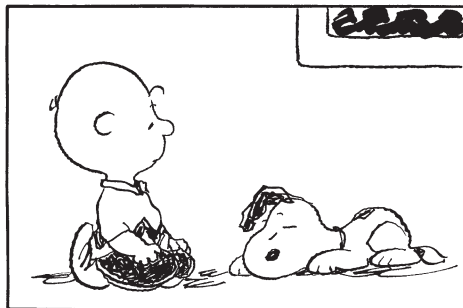
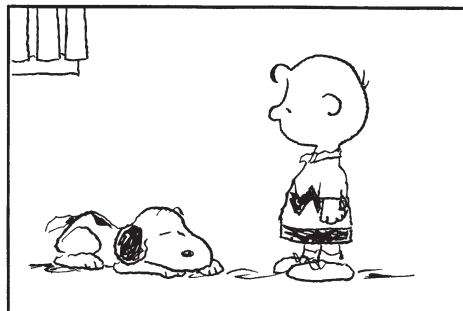

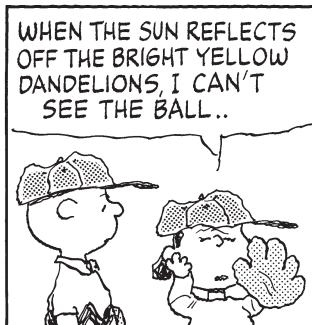
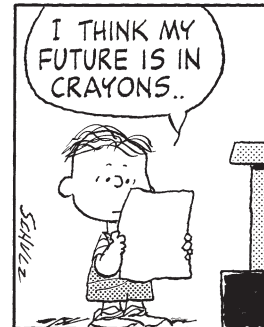
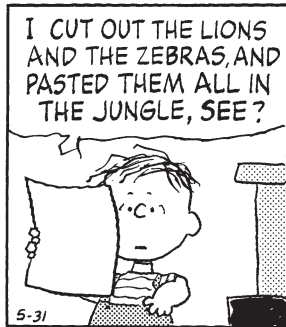

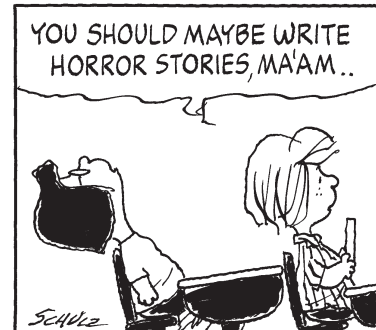

PEANUTS

by
SCHULZ

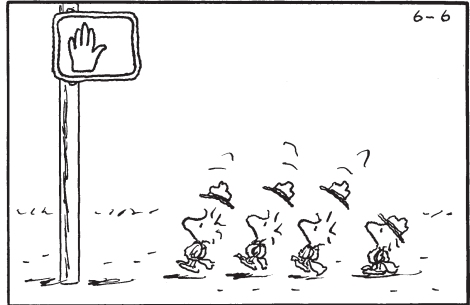
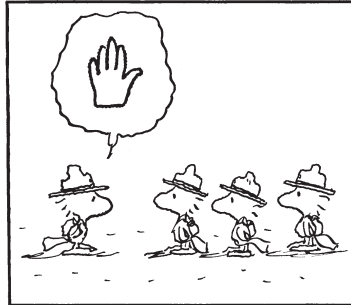
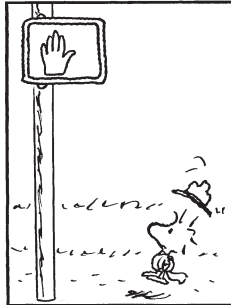
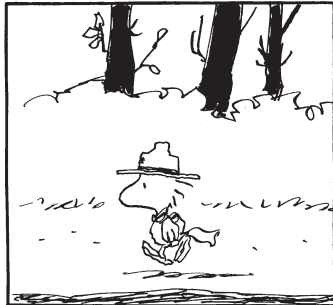
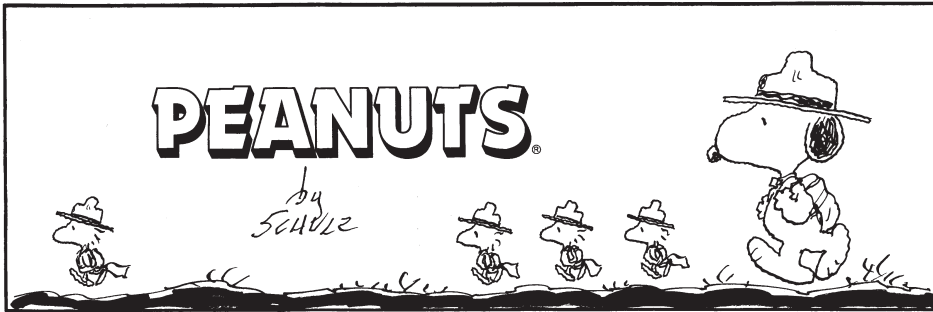

6-6

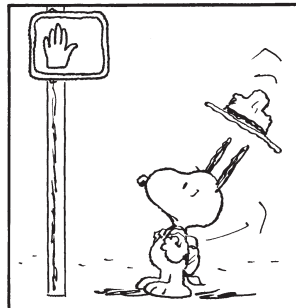
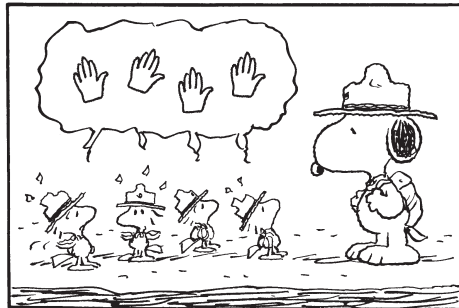

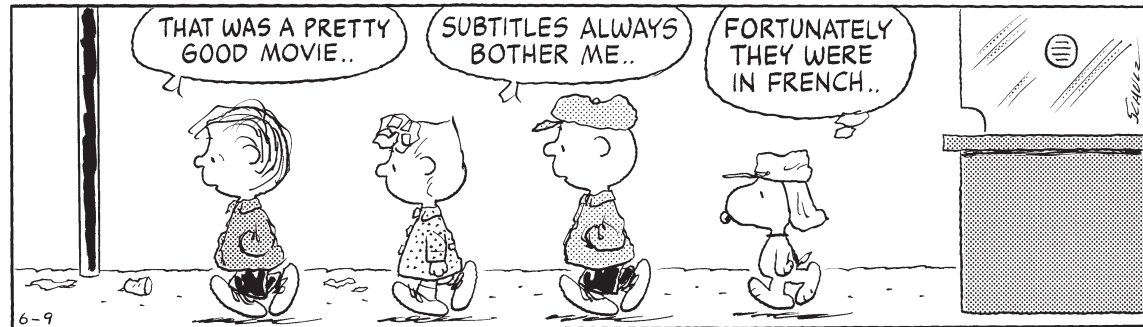
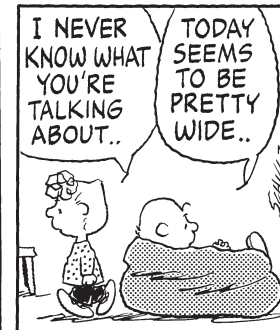
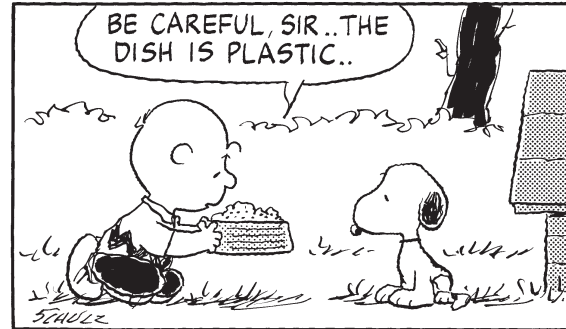

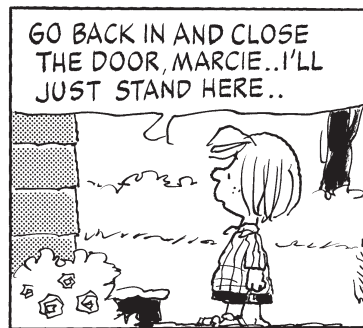

PEANUTS

by
SCHULZ

"LEARNING IS AN EXPERIENCE"



AT LEAST THAT'S WHAT THEY TOLD ME..



DO YOU MIND IF I STAND HERE BEHIND YOU, CHARLES?



IF I'M GOING TO BE A PITCHER, I WANT TO LEARN FROM THE MASTER..

MASTER?



THIS IS GREAT.. I CAN SEE HOW YOU GRIP THE BALL AND CONCENTRATE

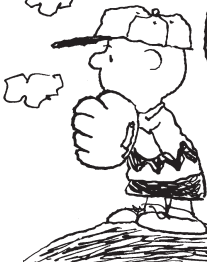

AND HOW YOU LEAN BACK BEFORE YOU..

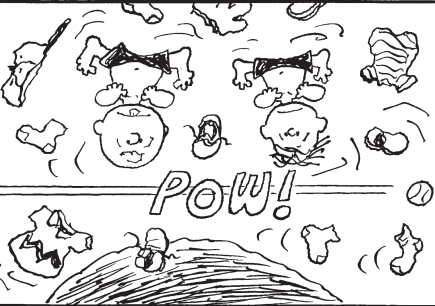

I THINK THIS MUST BE YOUR SHIRT..

YOU CAN LEARN A LOT FROM THE MASTER.. IS THIS YOUR SOCK?



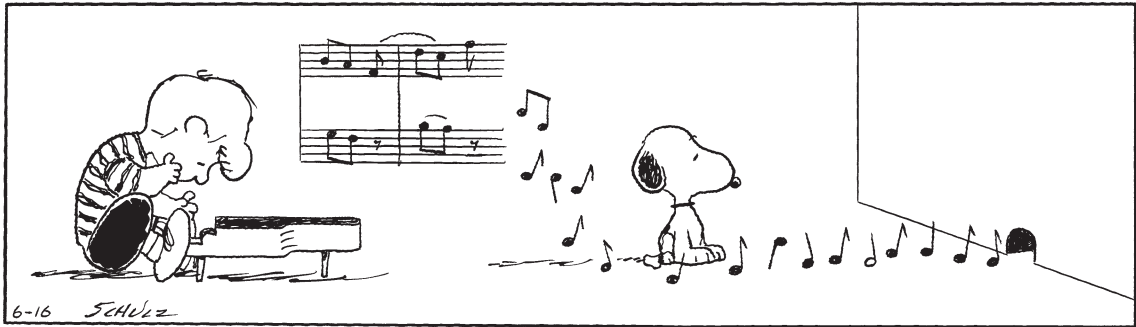
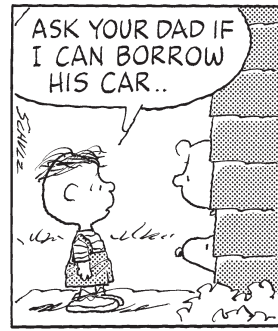
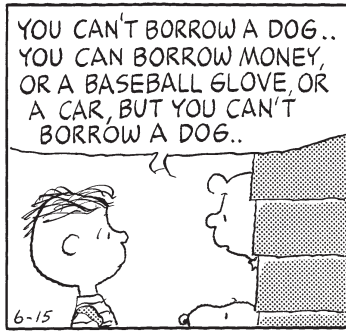
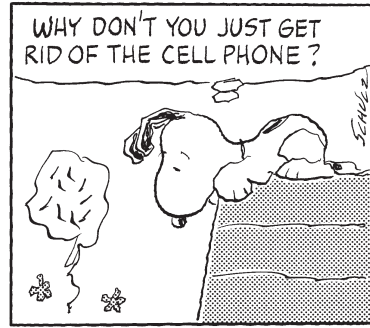
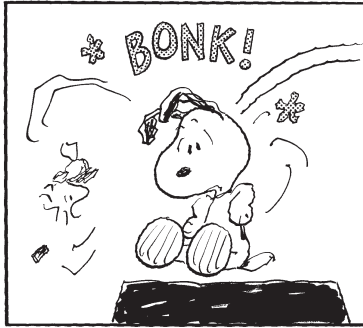
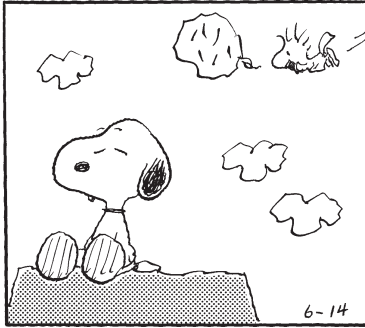

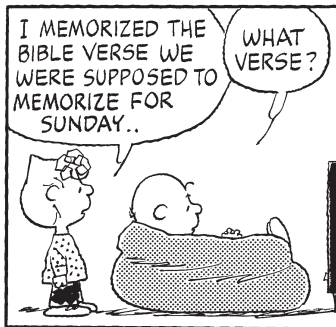
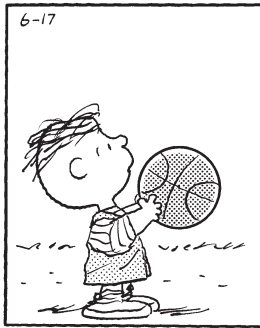

PEANUTS

by
SCHULZ

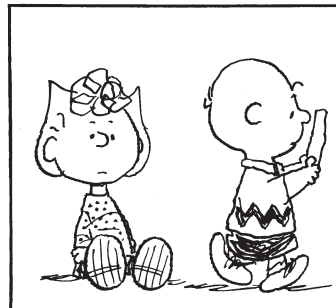
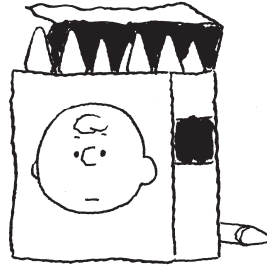

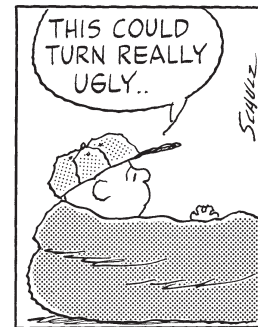
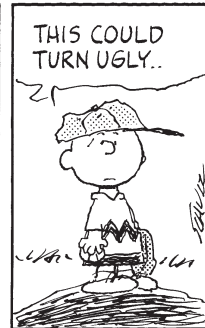
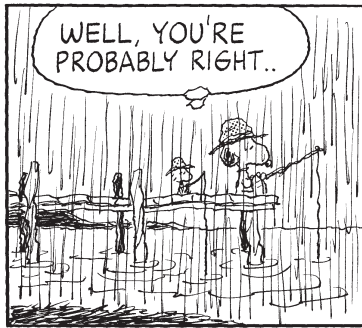

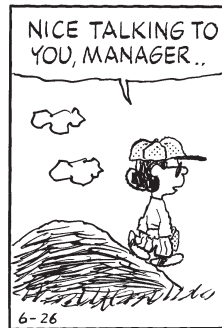
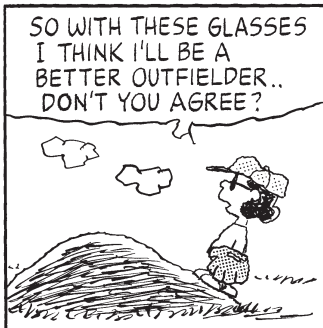
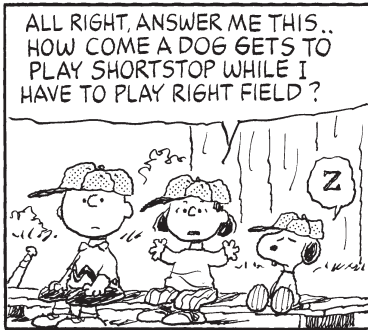

PEANUTS

by
SCHULZ

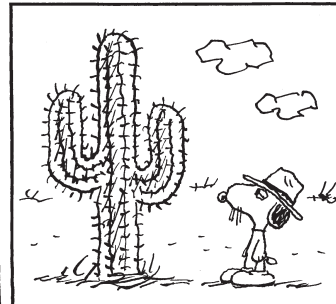
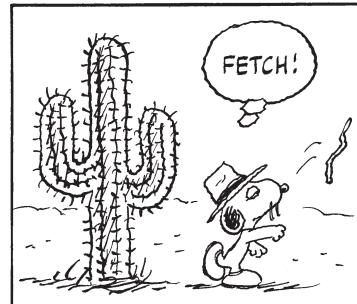
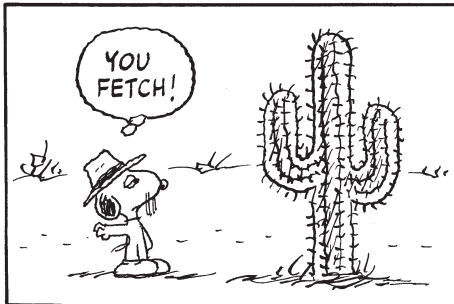
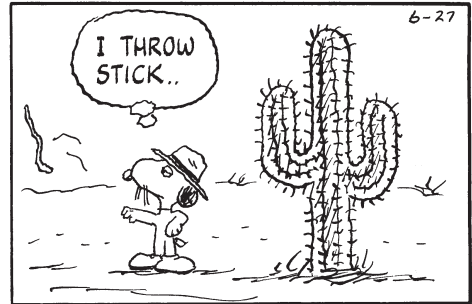
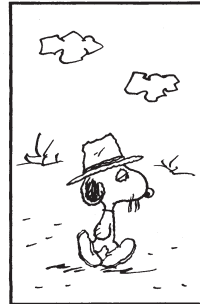
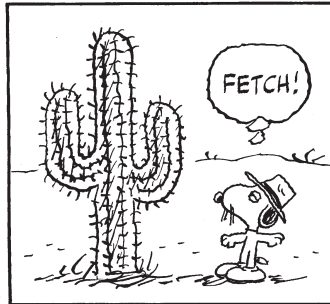
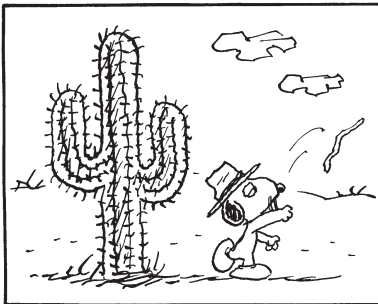
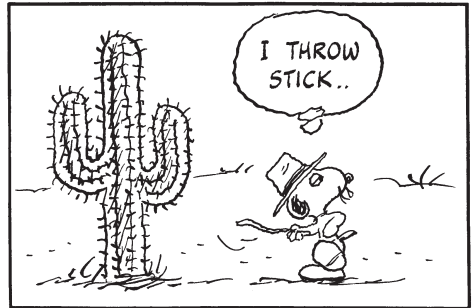
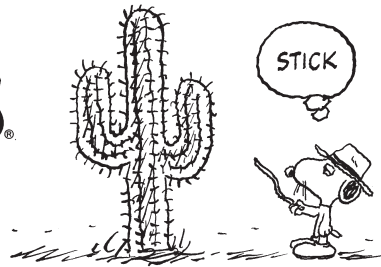

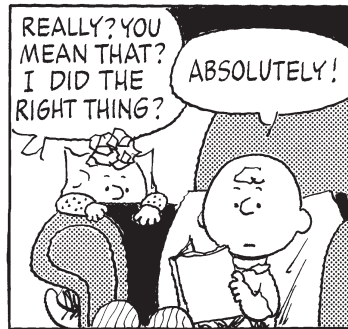
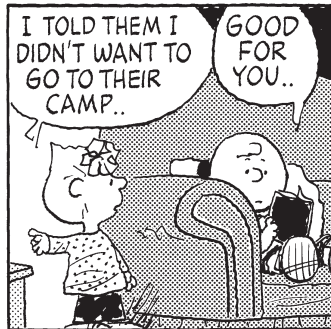
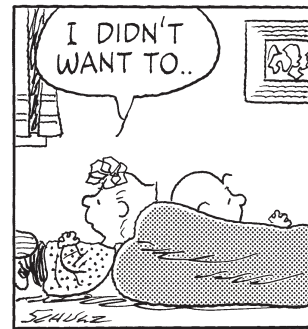
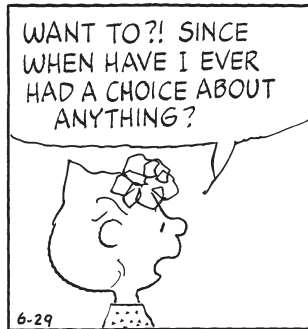

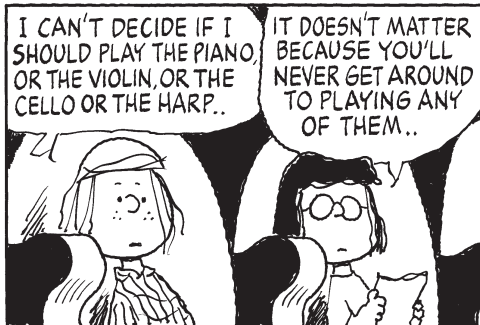
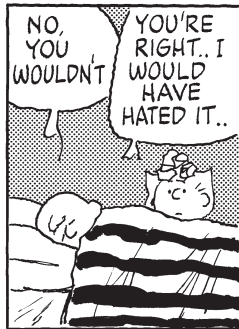
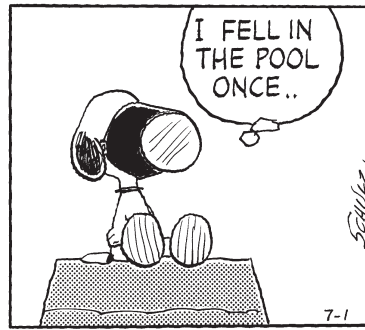
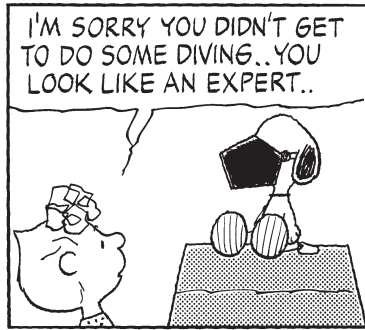

PEANUTS®

by
SCHULZ



LAST NIGHT..



GRAMPA READ IT TO ME..IT WAS IN
A STORY BY LEO TOLSTOY...

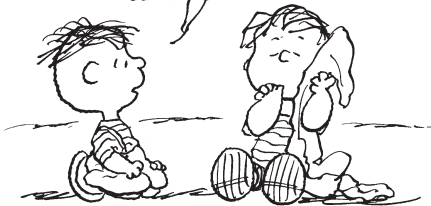

THIS WOMAN HAD FOUR CHILDREN,
SEE, AND THEY ALL SLEPT
TOGETHER IN A BIG CRADLE...

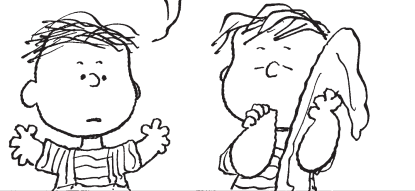

WHEN SHE PUT THEM TO BED,SHE GAVE
EACH ONE A "SUCKING RAG!!"



7-4

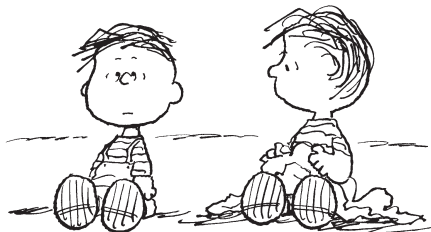

ENJOY YOUR
"SUCKING RAG"

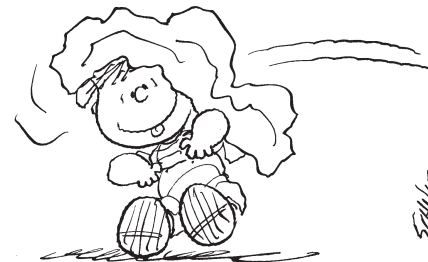

SCHULZ

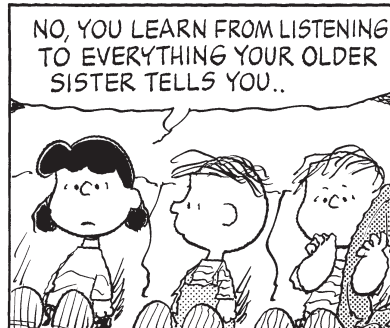
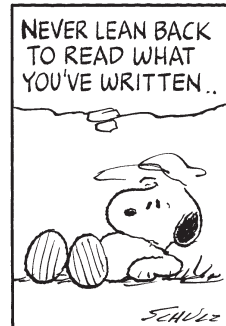
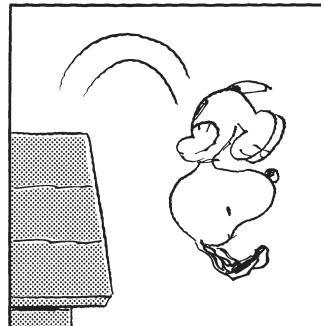
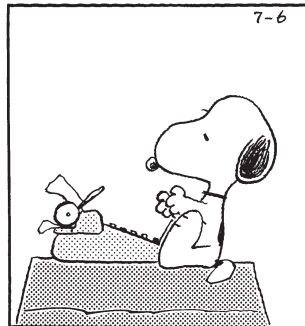
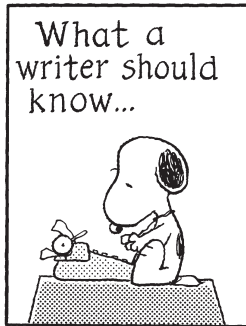
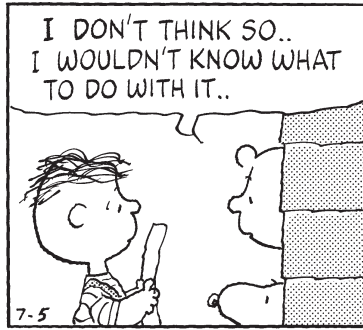
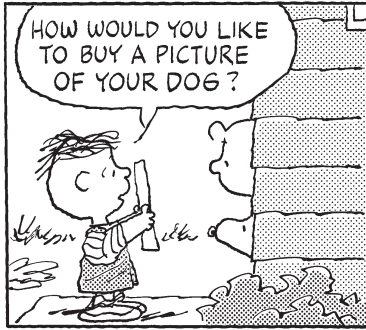

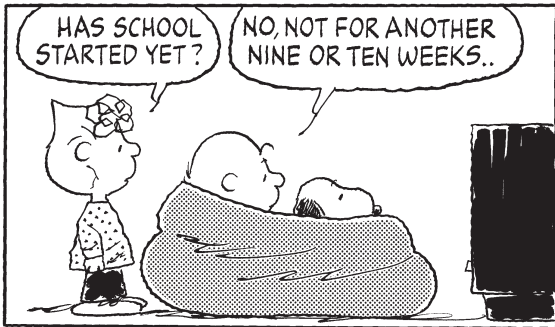
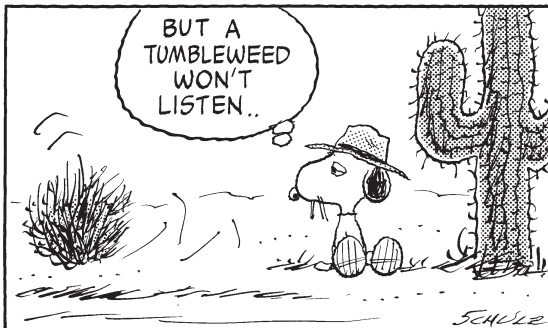
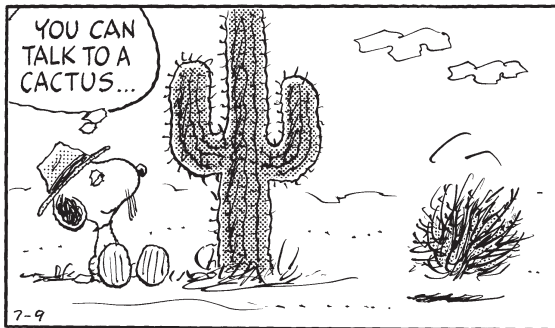
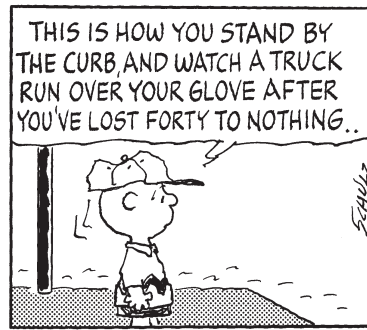

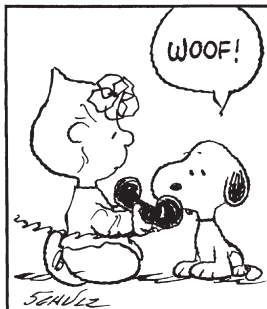
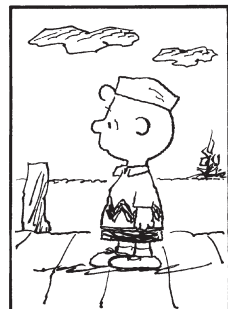
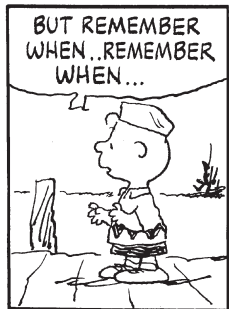
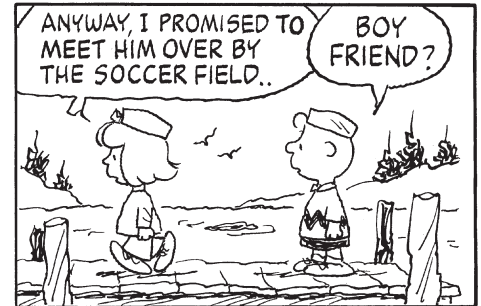
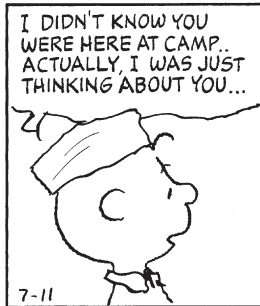
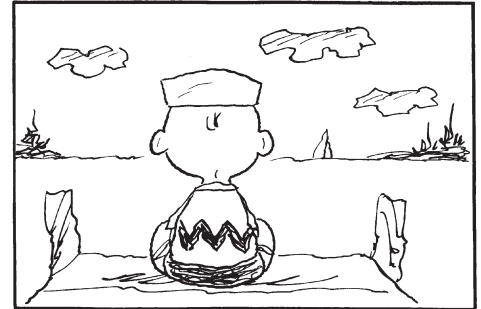
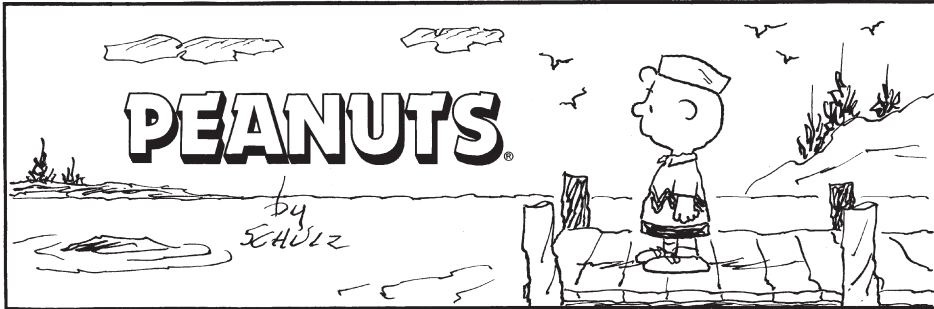

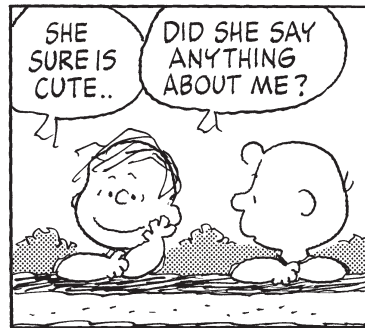

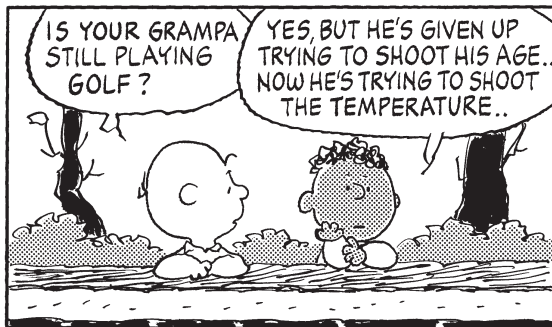
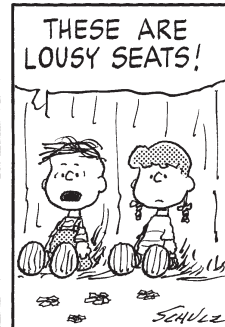

PEANUTS

by
SCHULZ

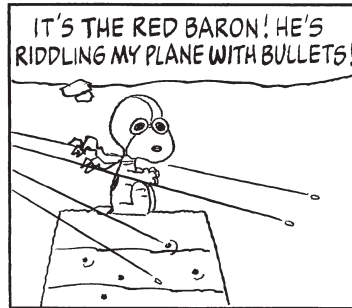
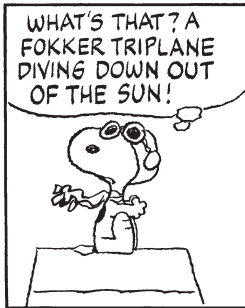
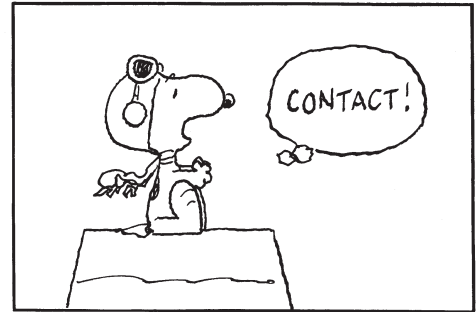
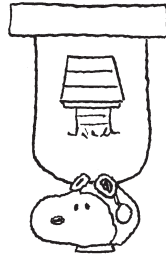

7-18



SCHULZ

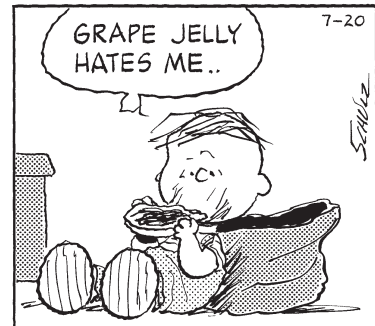
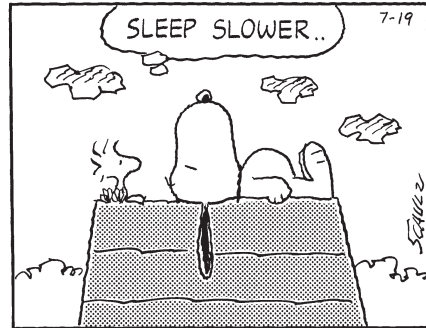

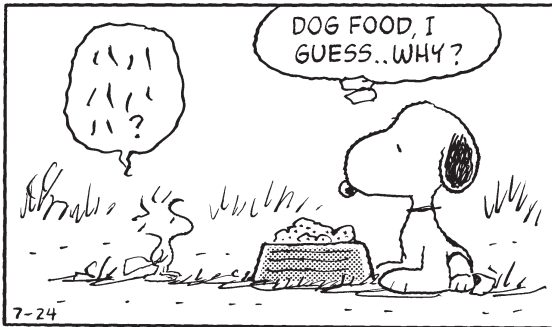

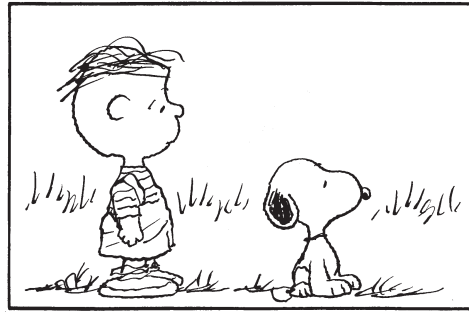
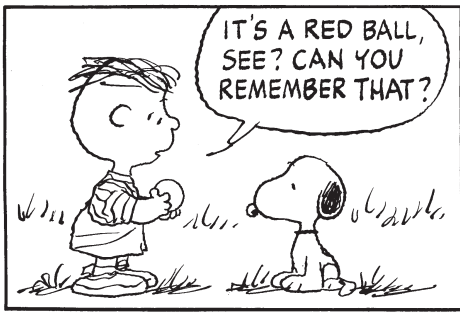
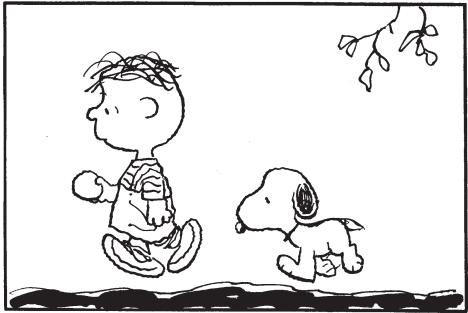
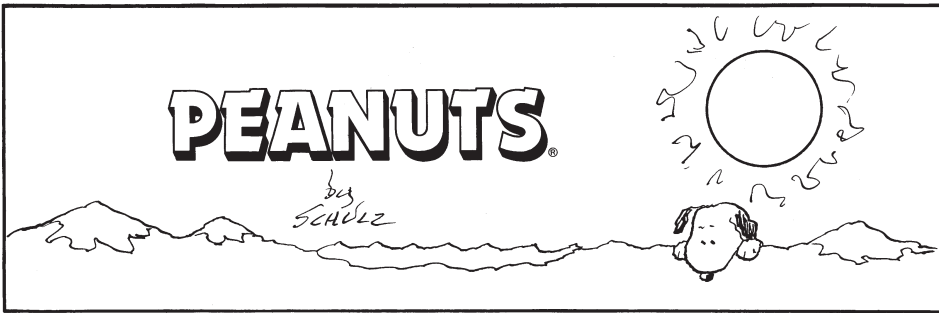

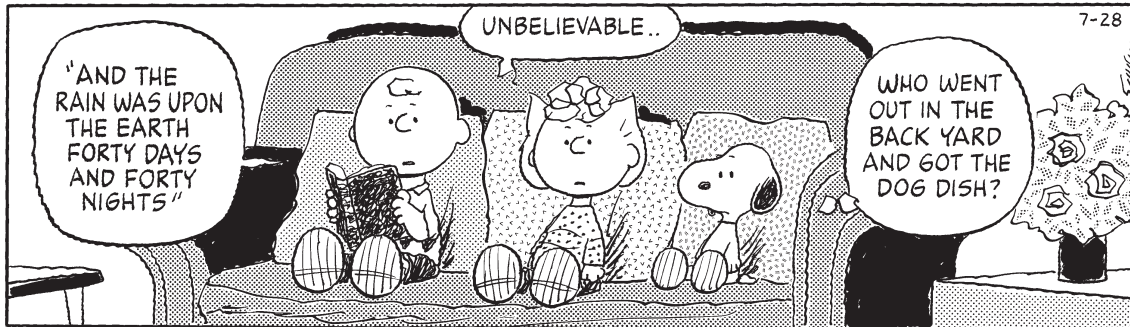
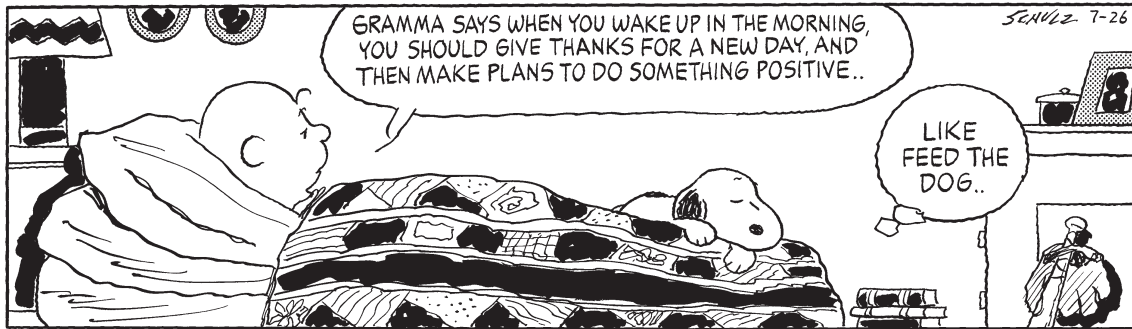

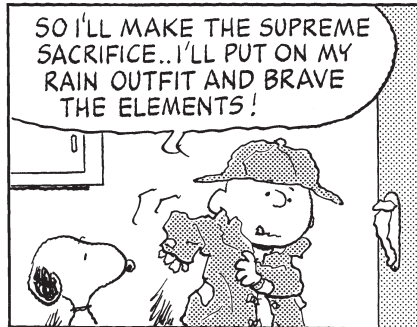

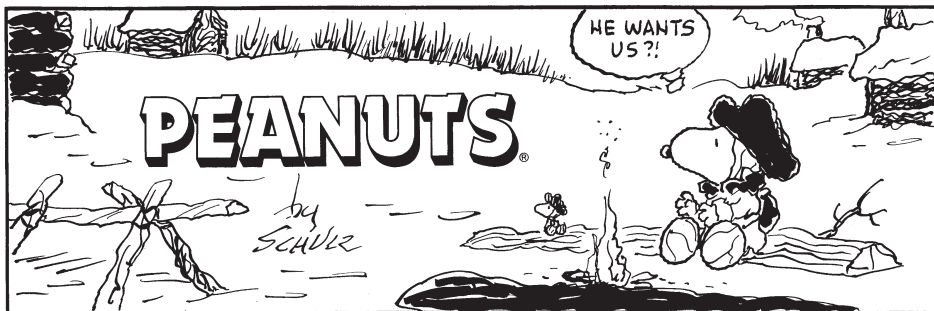

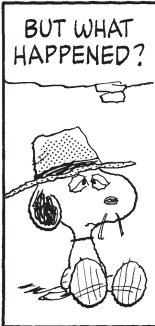
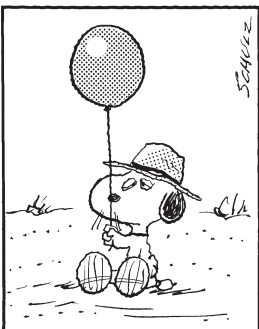
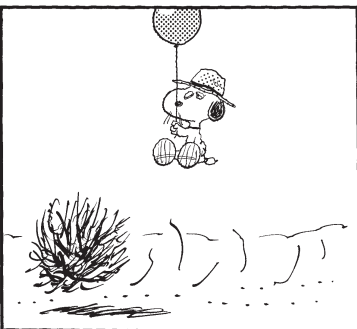
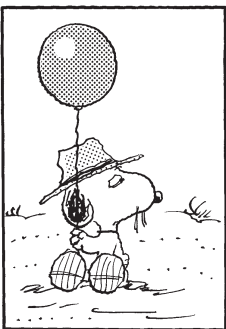
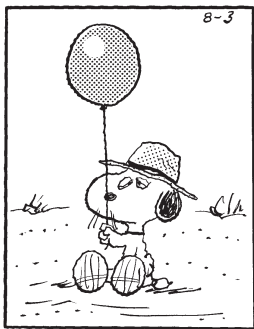
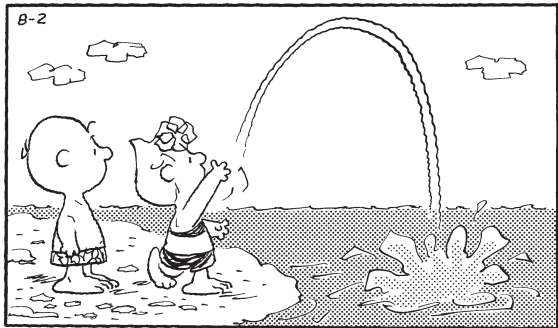

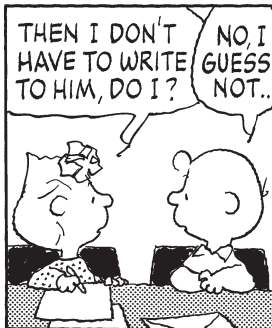
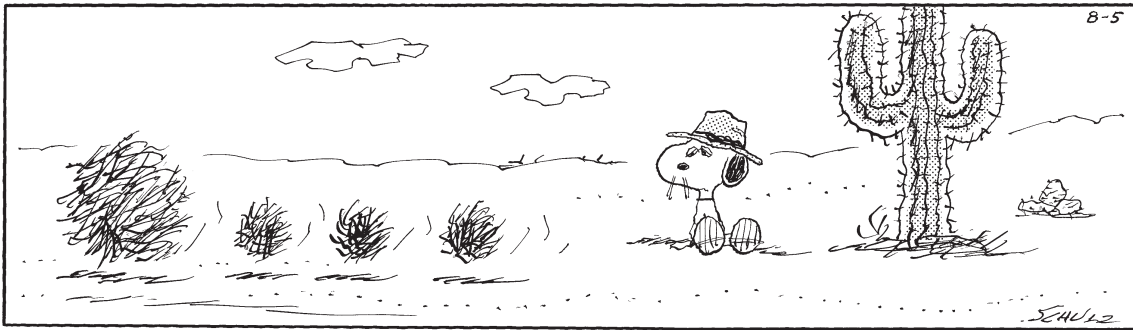

PEANUTS

by
SCHULZ

"Someday,"
he said.



"Someday we'll
meet again."

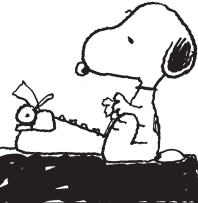

The
End

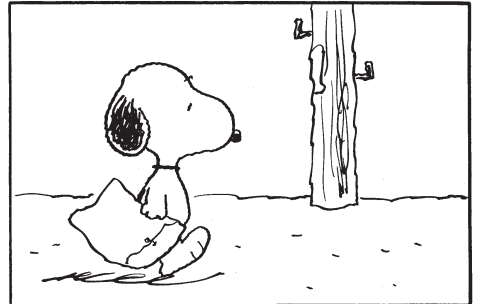

8-8

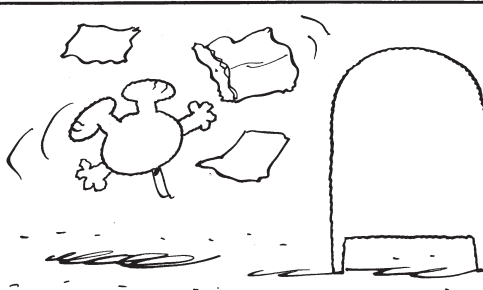
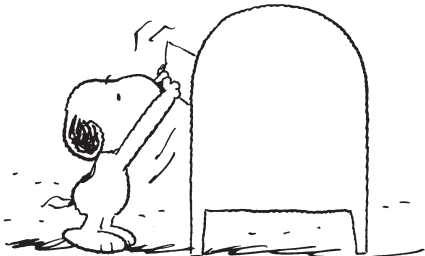

I THOUGHT HE'D LIKE
IT.. A MAILBOX WAS
THE HERO..



SCHULZ





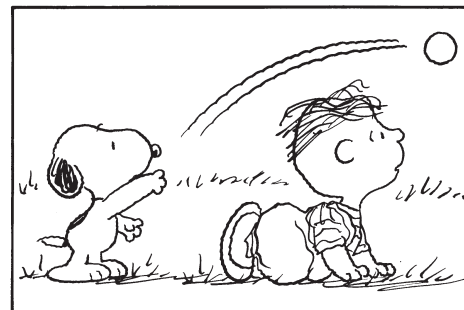
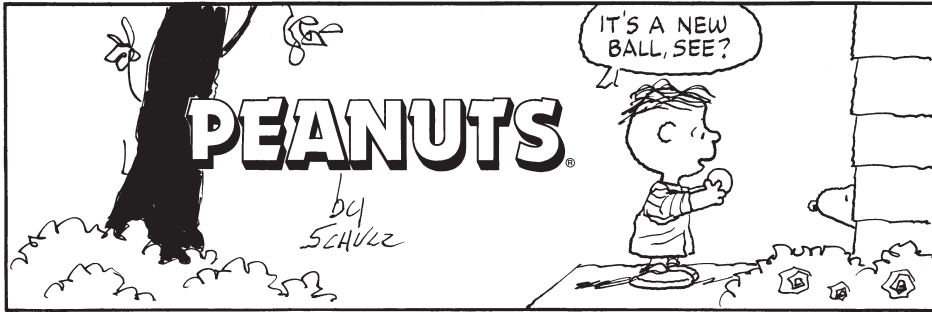

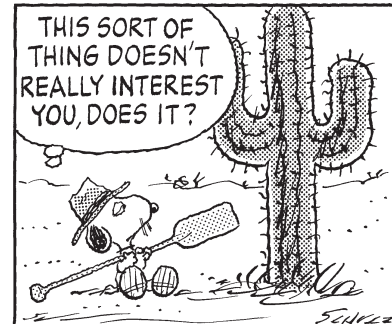
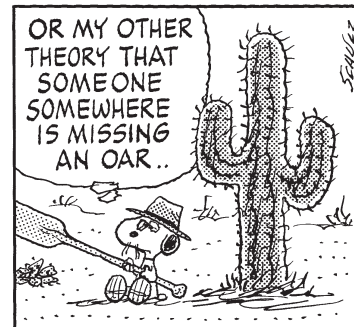
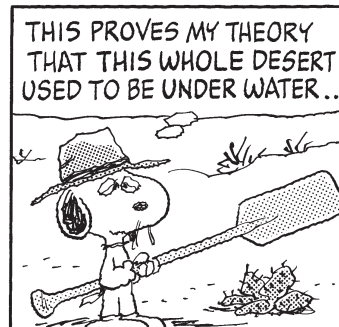
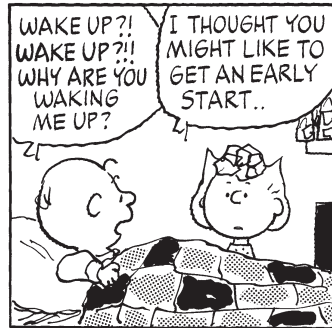

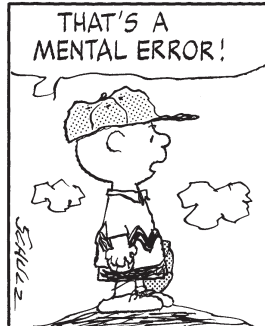
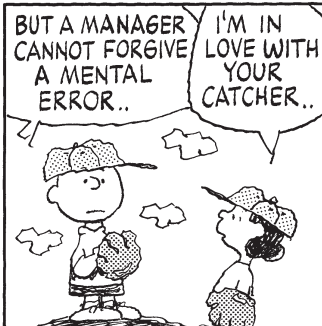
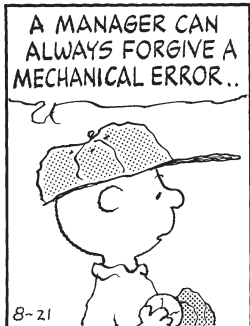
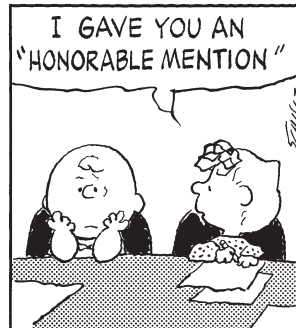
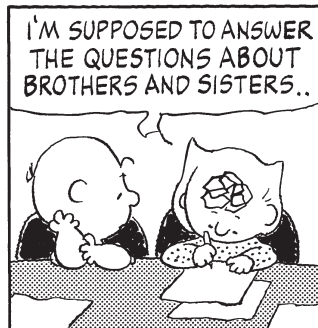
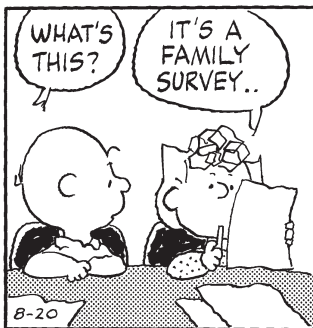
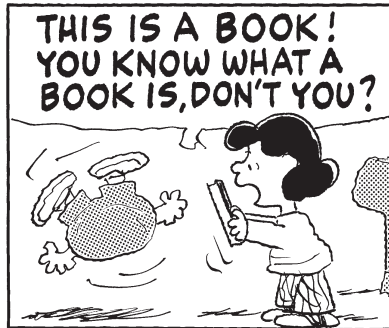

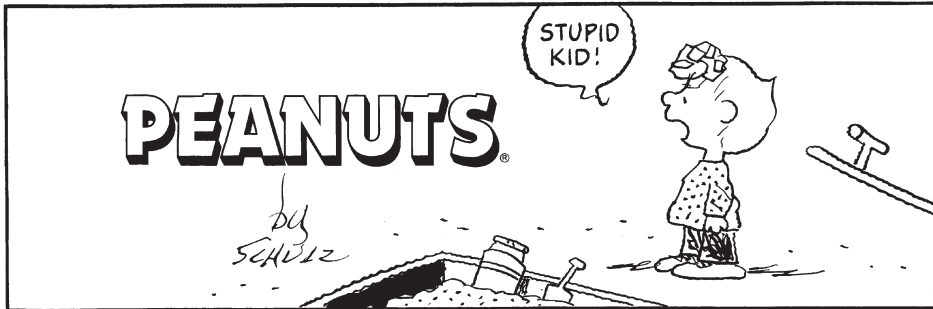

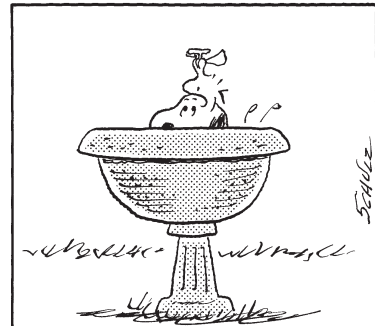
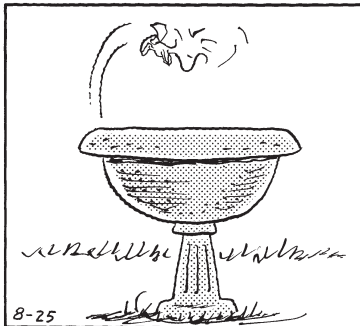
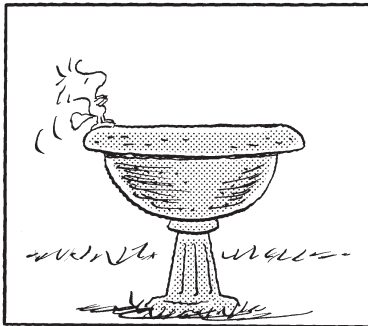
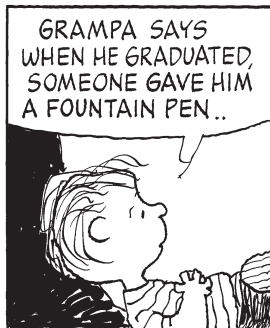
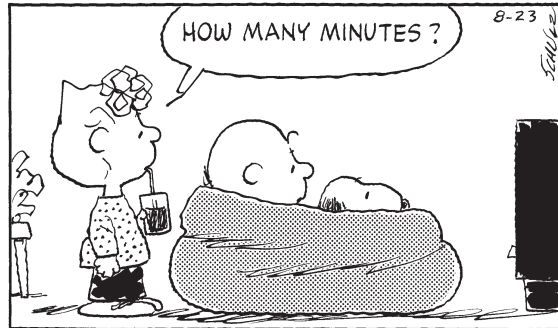
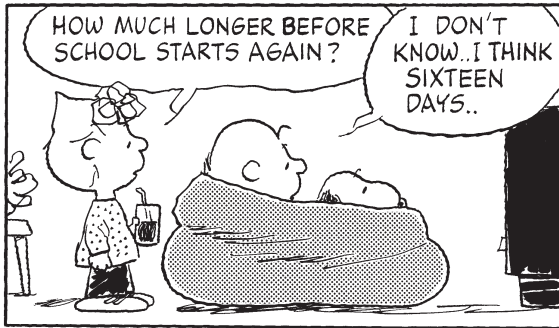

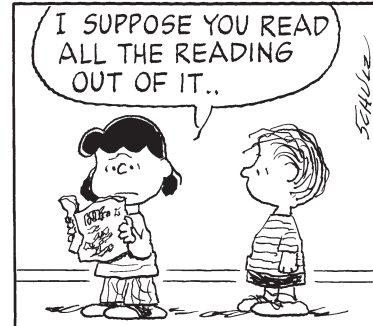
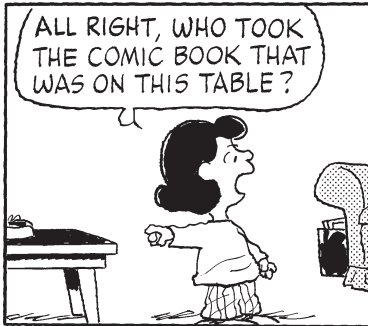
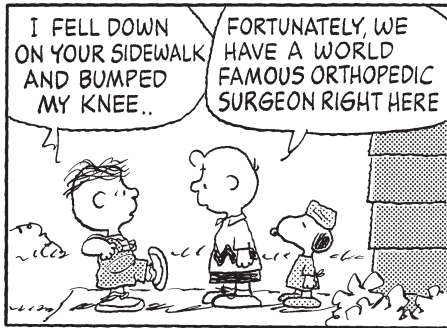

PEANUTS®

by
SCHULZ



WHO ARE WE PLAYING?
WHY ARE WE PLAYING?
WHAT ARE WE PLAYING?



OH, NO..
HERE SHE COMES..



HEY, MANAGER..
I HAVE A QUESTION..



WHAT AM I PLAYING TODAY,
RIGHT FIELD OR RIGHT WING?

8-29



WELL, I'VE SEEN YOU PLAY
RIGHT FIELD SO I THINK YOU'D
BE GREAT AT RIGHT WING..



RIGHT WING, HUH? WELL, I
GUESS THAT MAKES SENSE..



DO YOU HAVE ALL
YOUR EQUIPMENT
HERE?

SURE, I'M
ALWAYS READY
FOR ANYTHING..



I WONDER
IF HE WAS
PUTTING
ME ON..

SCHULZ

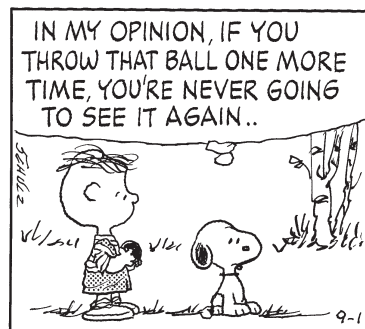
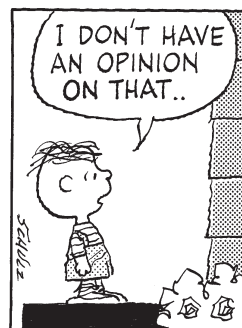
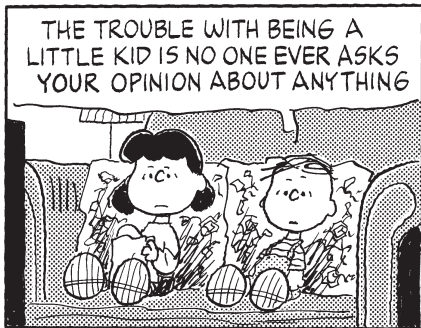

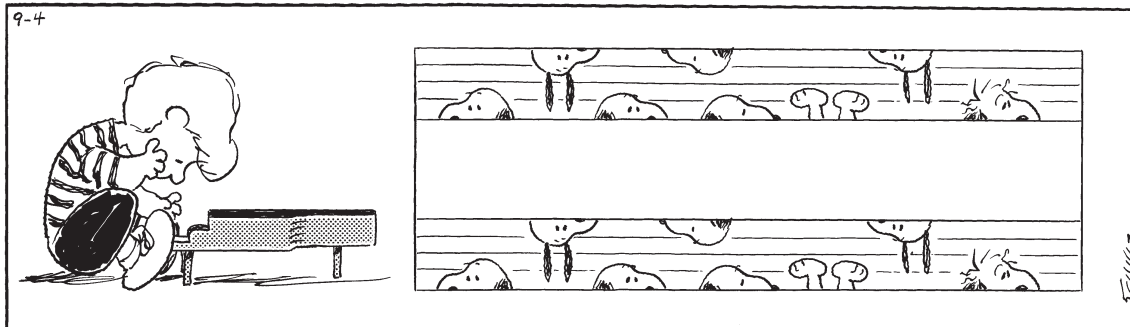

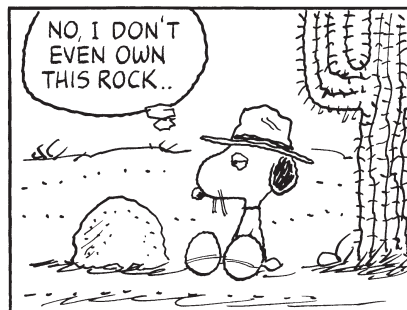
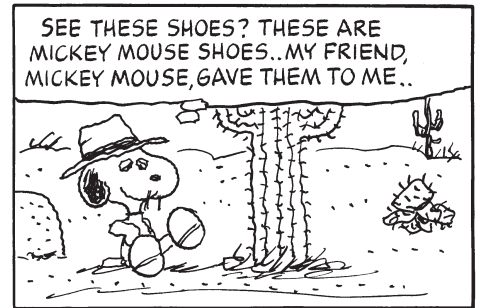
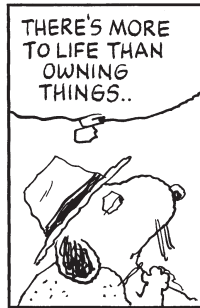
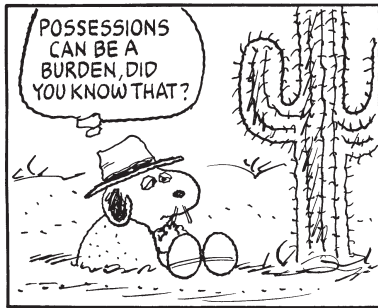
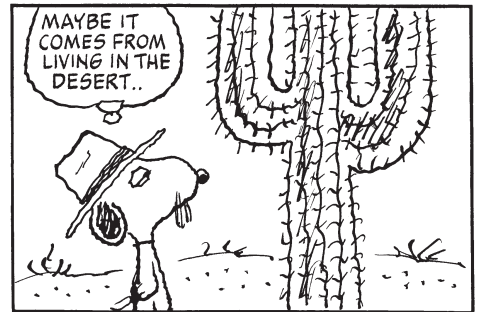
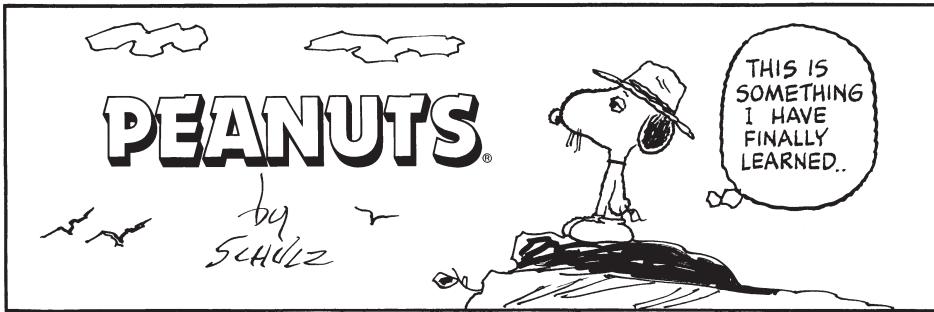

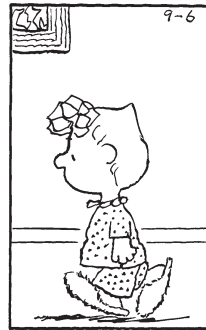
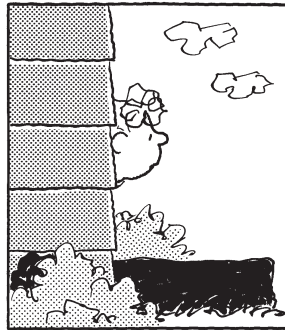

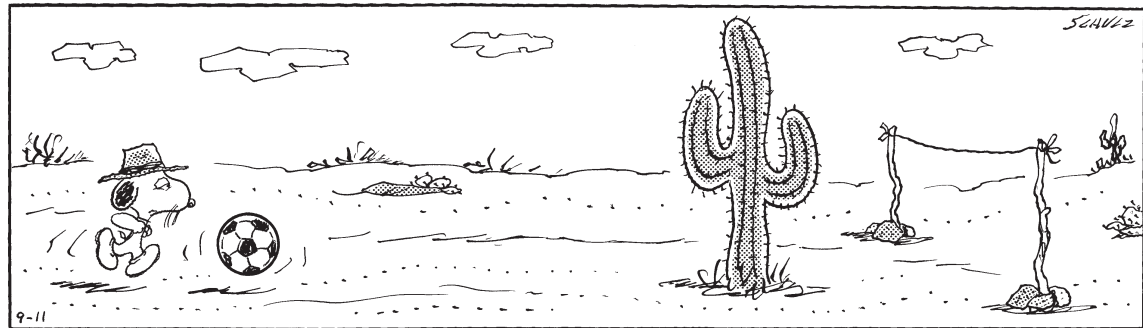
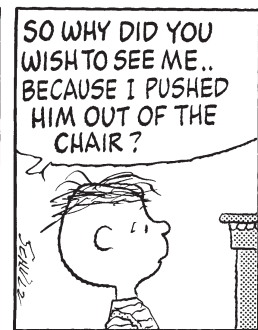
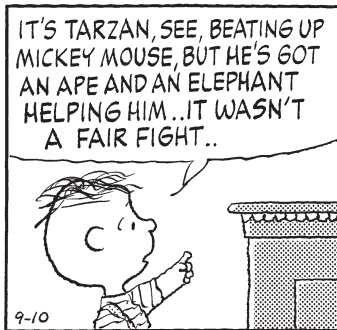
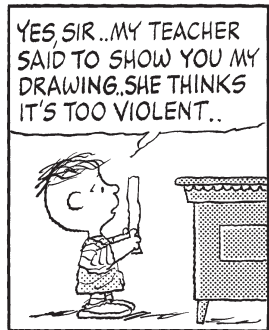

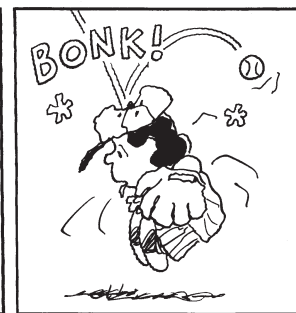
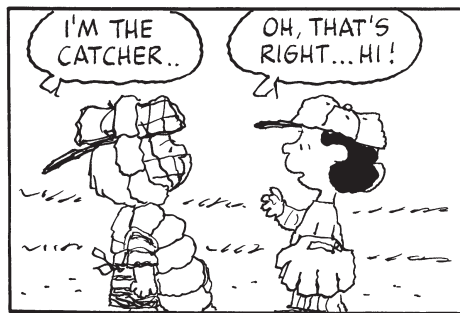
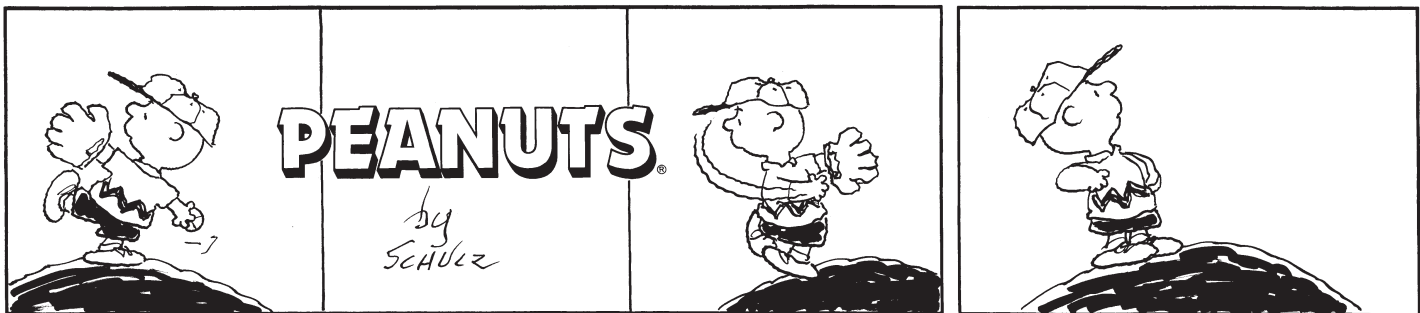

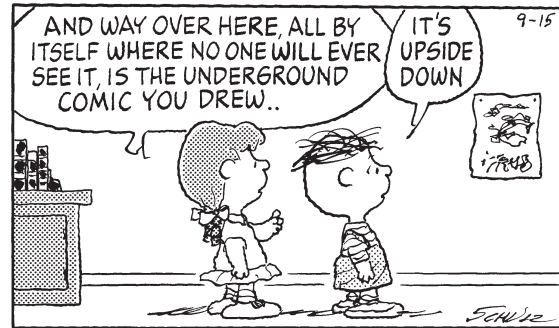
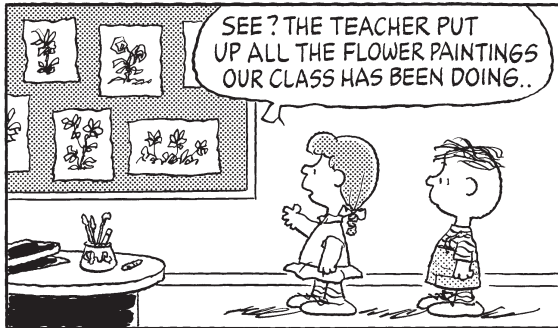
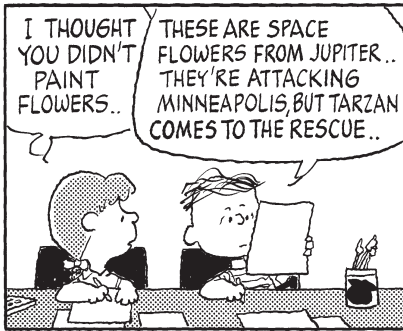
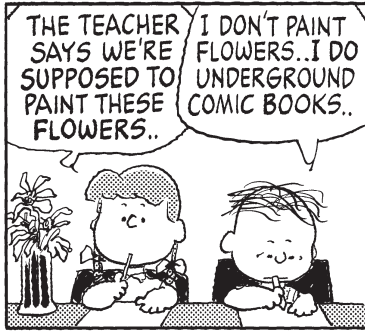

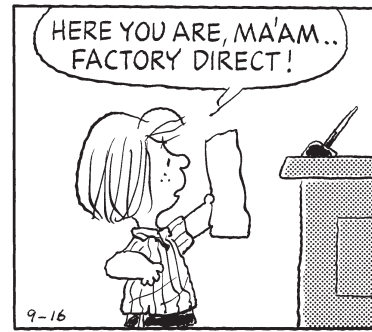
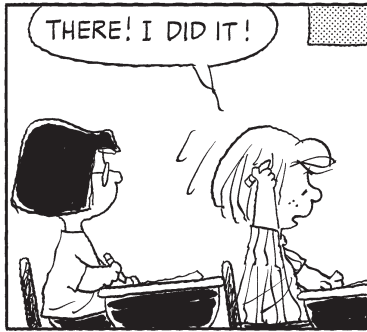

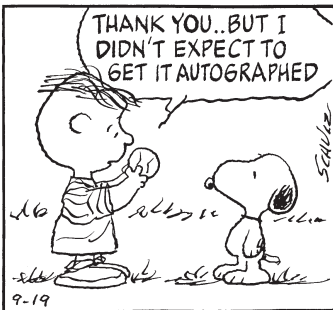
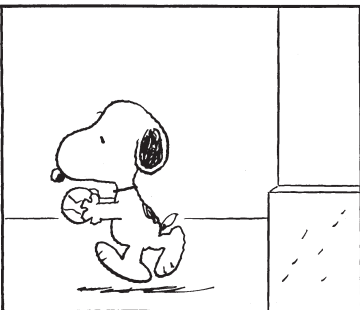
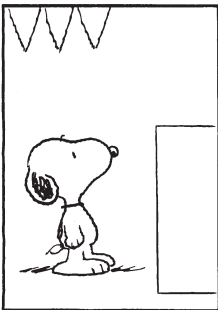
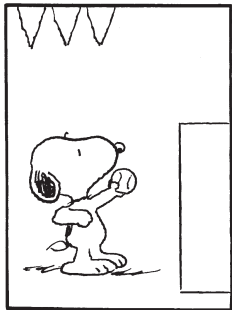
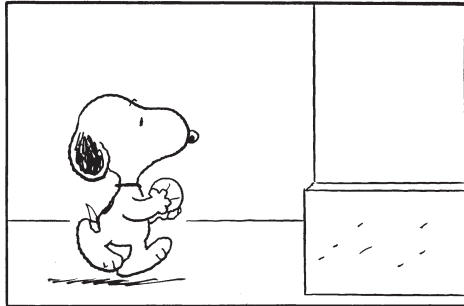
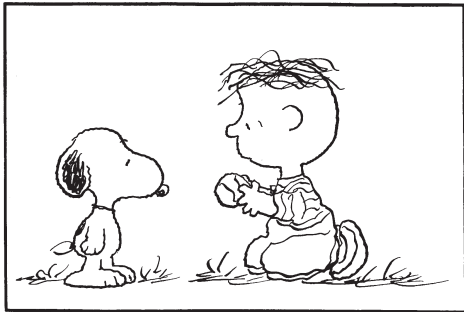
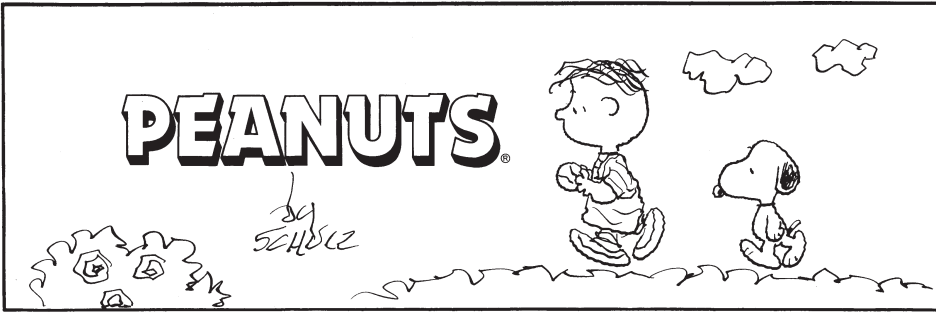

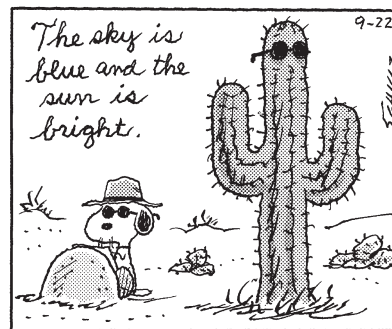
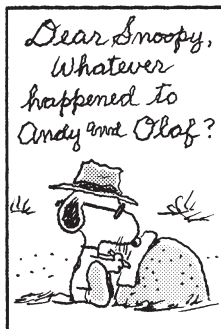
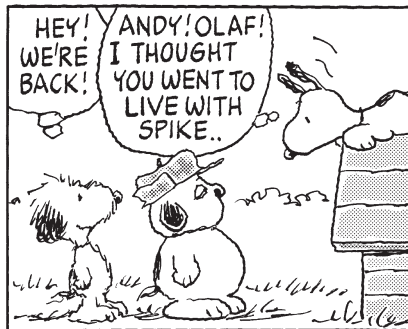

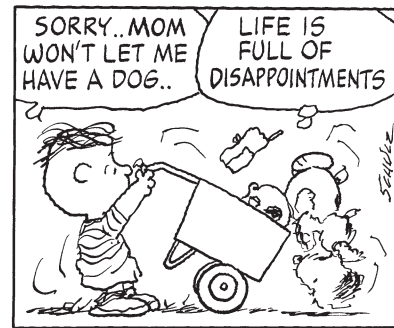

PEANUTS

by
SCHULZ

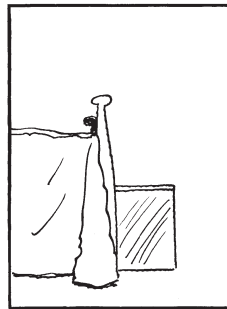
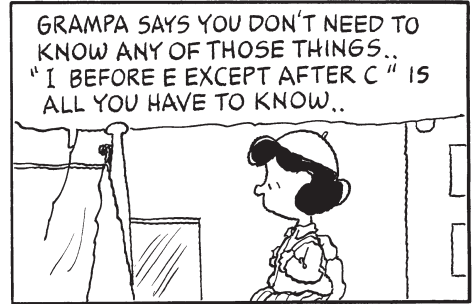
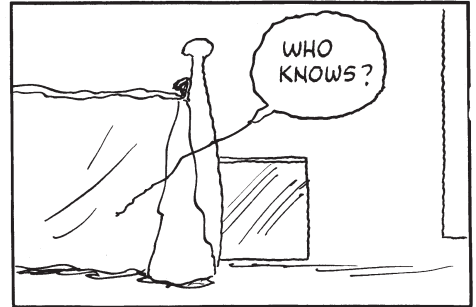

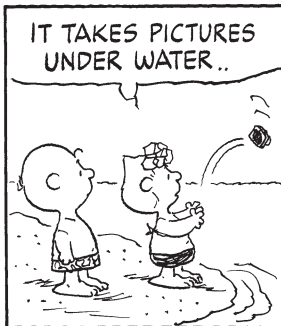
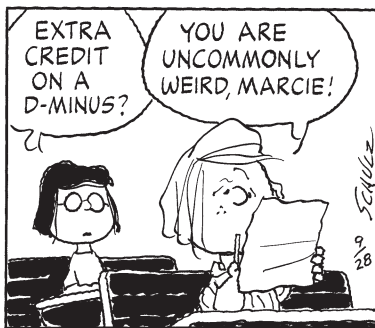

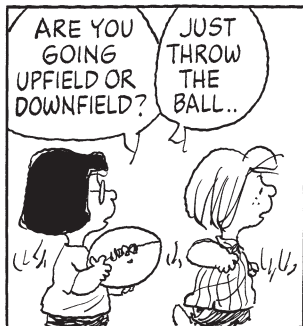
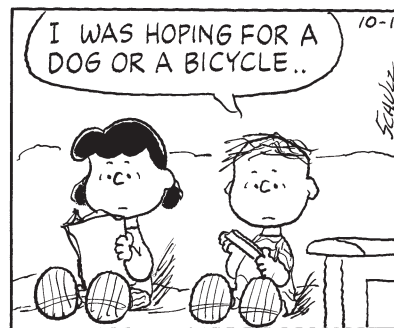
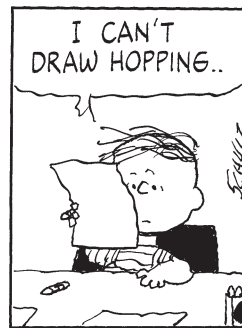

PEANUTS®

by
SCHULZ

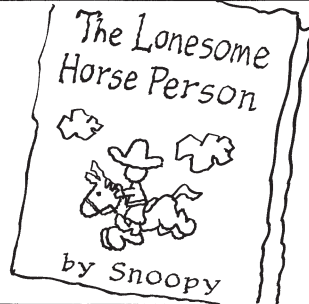

Chapter Twenty

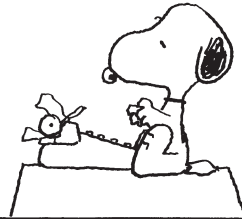

The sun was setting as the horse person rode back to his cattle place.



Suddenly, he saw some cow takers.

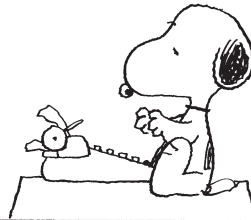

WHAT ARE "COW TAKERS"?

10-3



PEOPLE WHO KIDNAP OTHER PEOPLE'S COWS..

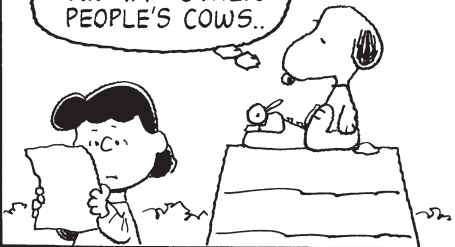

THIS IS TOO DUMB.. I CAN'T READ ANY MORE!



THE NEXT PART IS THE BEST.. "THE WOUNDED HERO LAY IN THE DUST.."



The robins circled overhead.



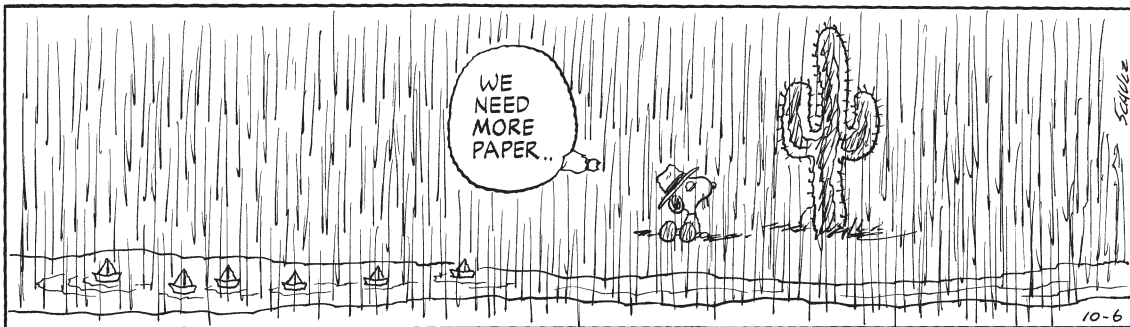
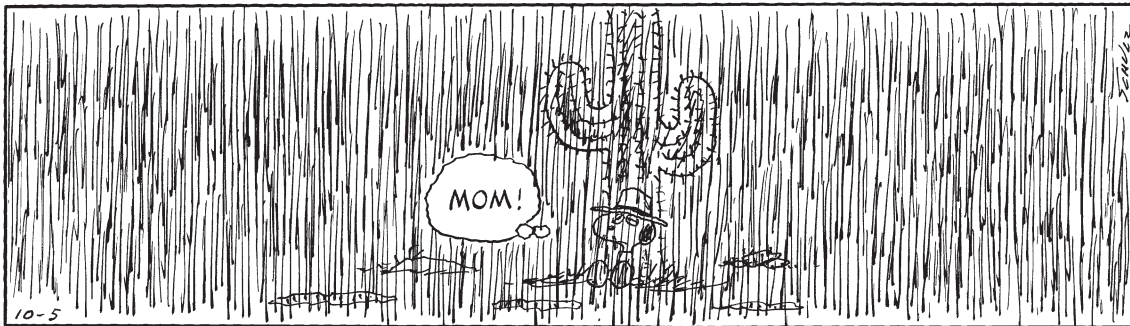
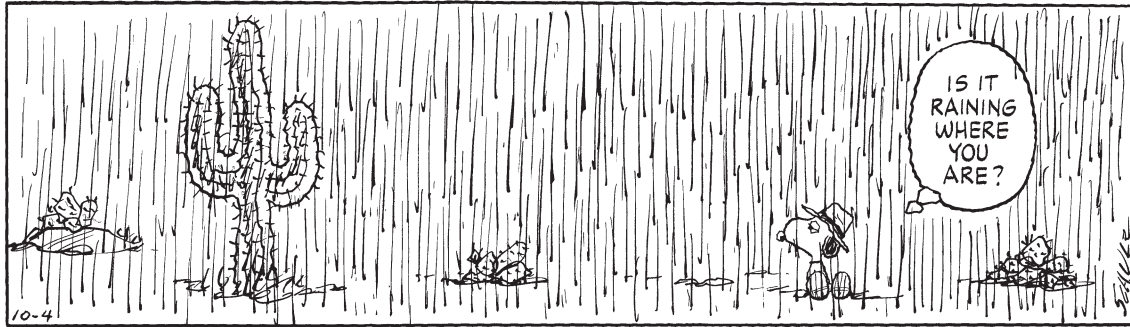

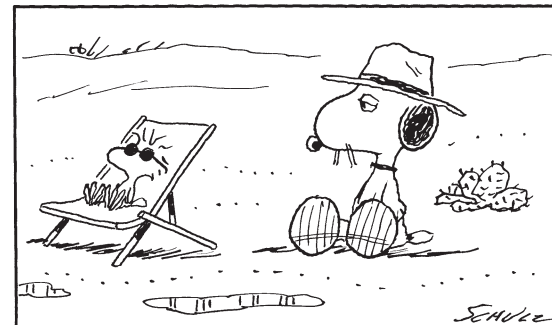
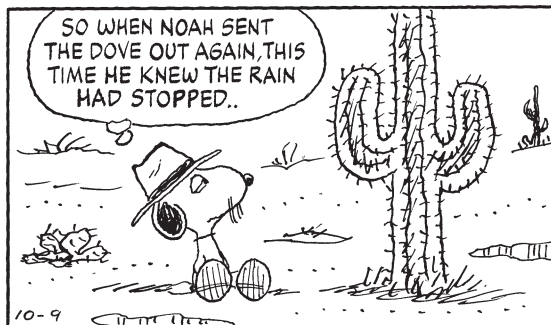
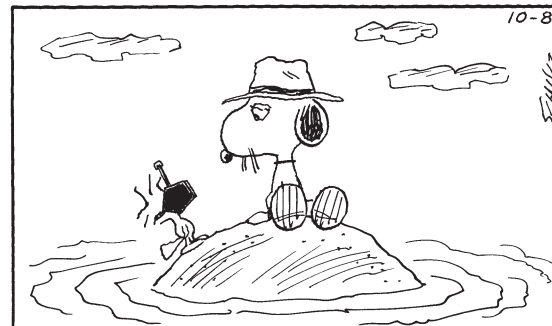
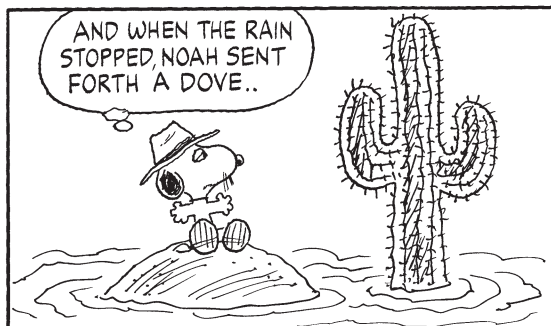
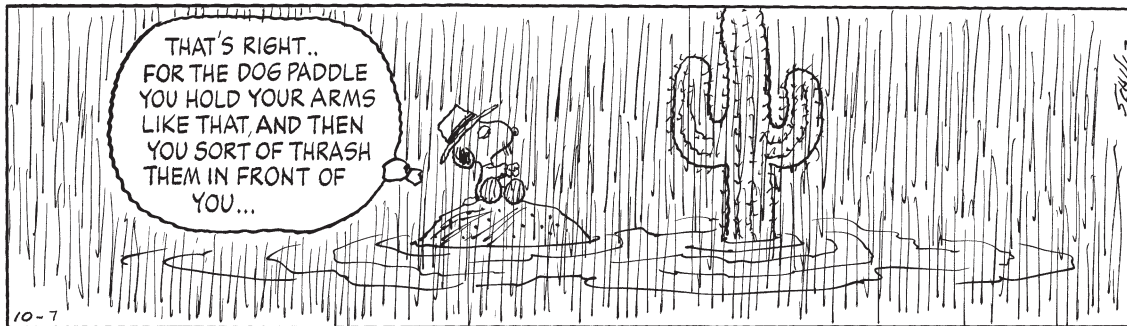

PEANUTS

by
SCHULZ

I CAN
DO THIS..

KICK!

IT'S CALLED
"KICK BOXING
MADE EASY"

JAB! PUNCH!
JAB! PUNCH!

ROUNDHOUSE!

KICK!

JAB!
JAB!
PUNCH!
PUNCH!

JAB! PUNCH!
ROUNDHOUSE!

KICK!

NO, ACCORDING
TO THIS, IT
DOESN'T MEAN
YOU WON..

10-10

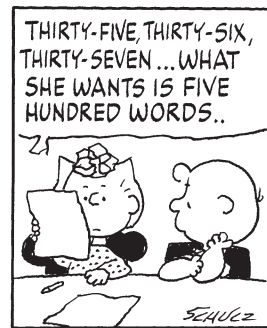
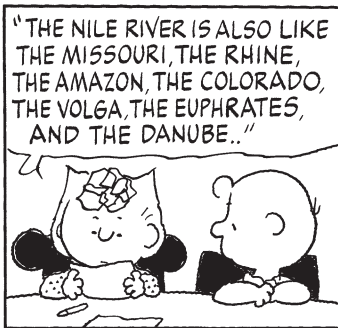
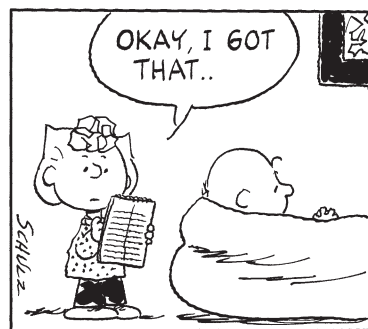
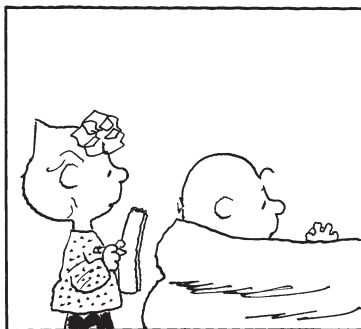
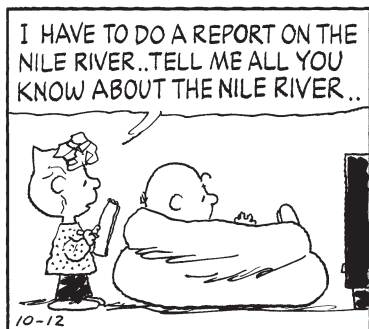
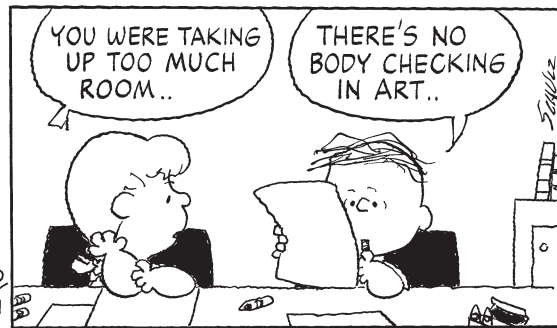
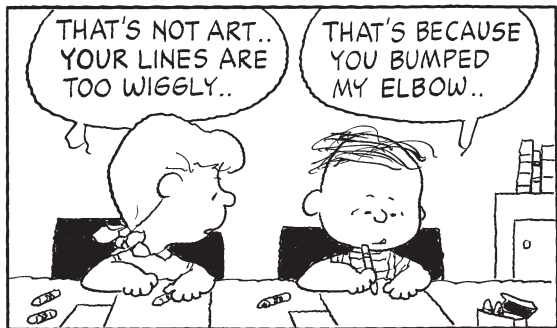

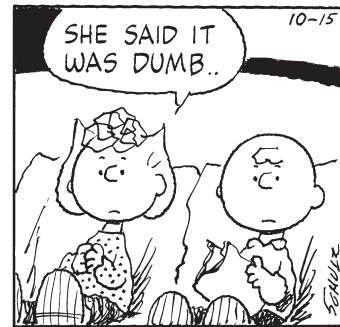
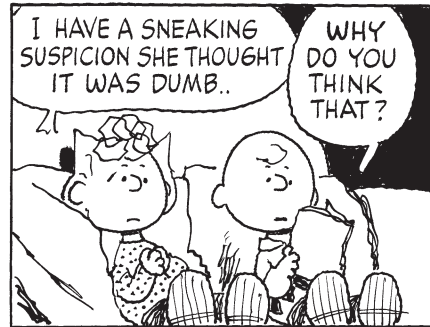

PEANUTS

by
SCHULZ

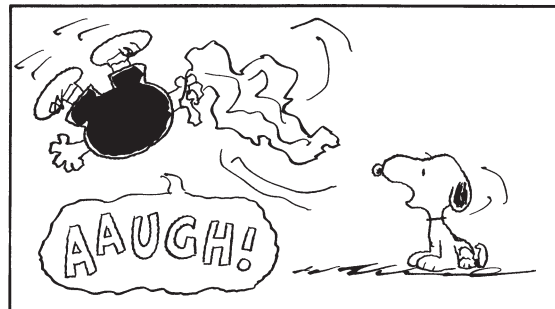
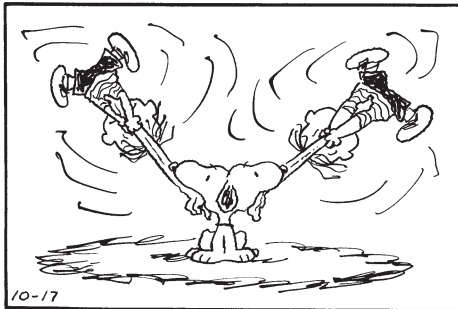
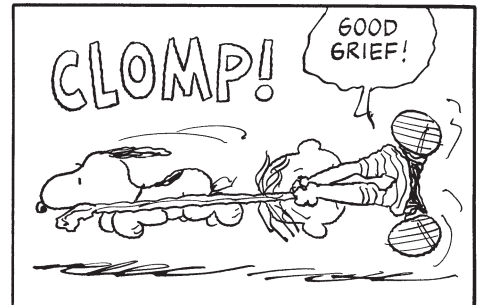
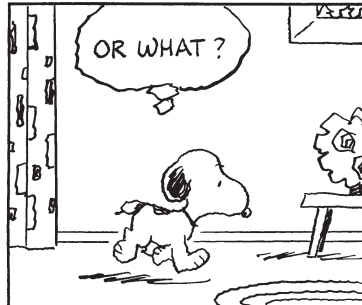
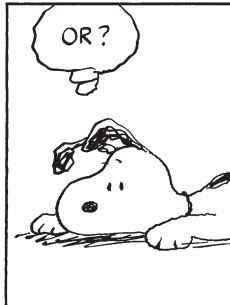
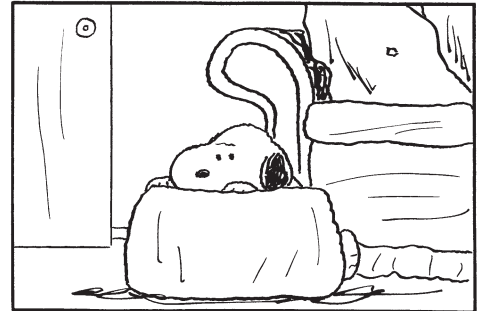

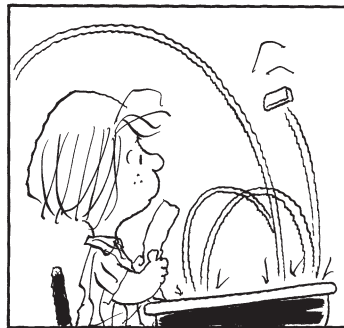
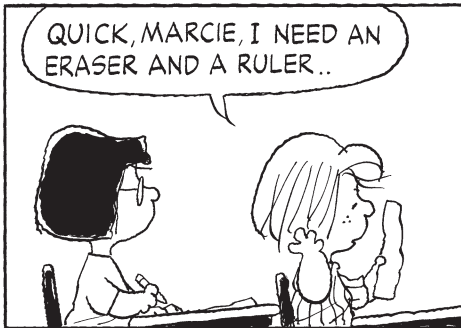

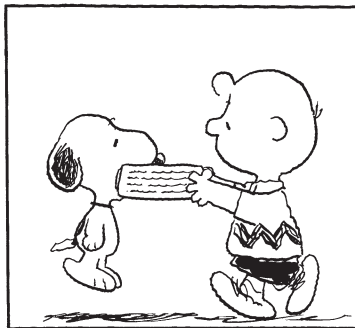
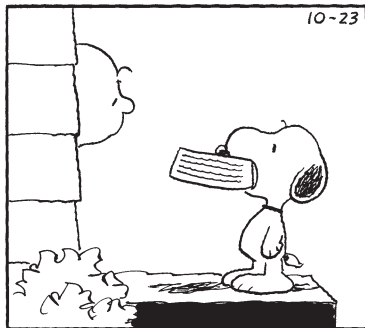
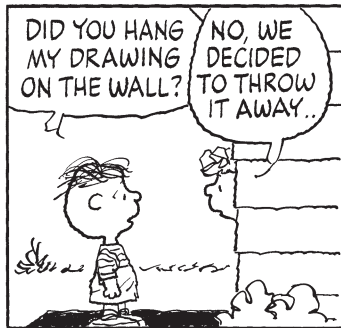
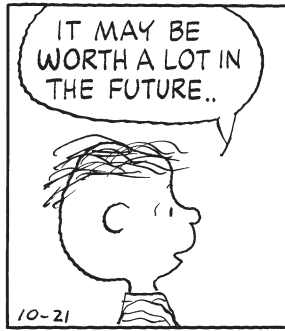

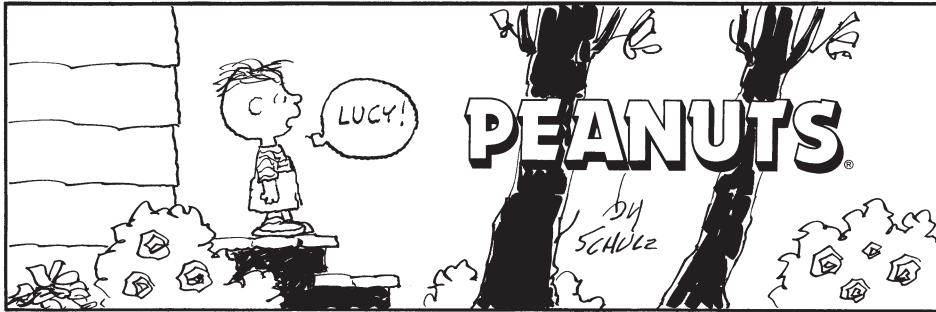

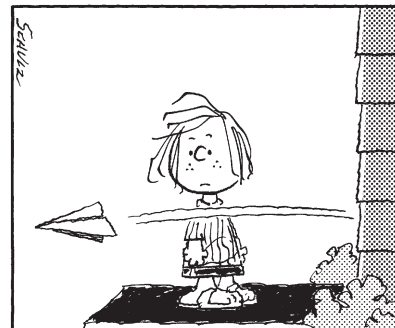
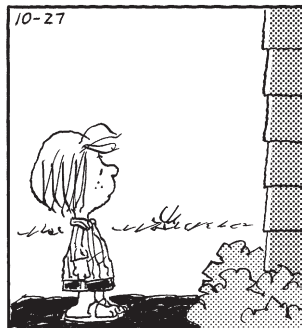
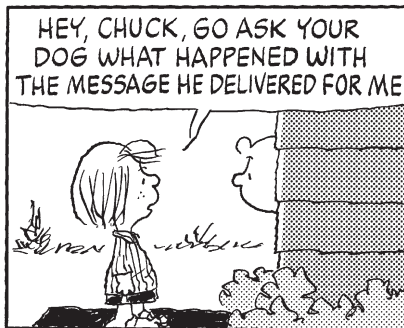
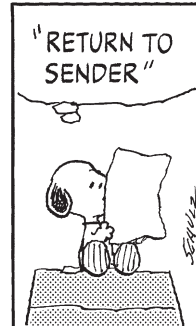
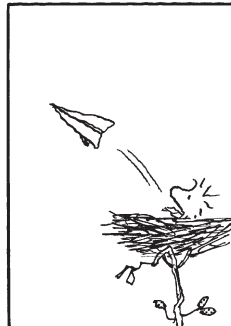
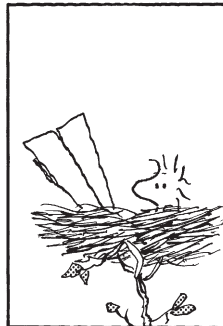
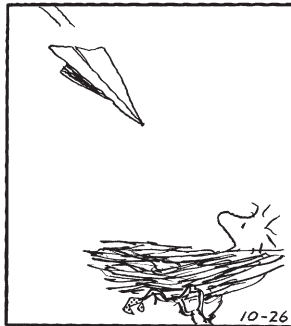
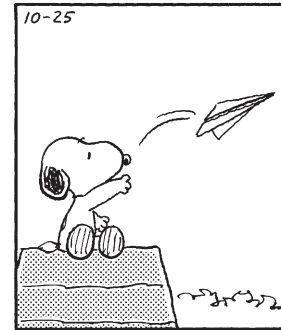
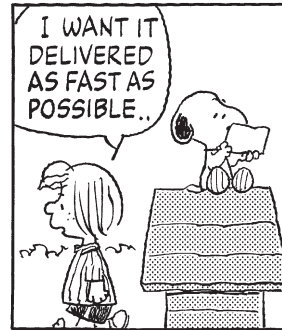
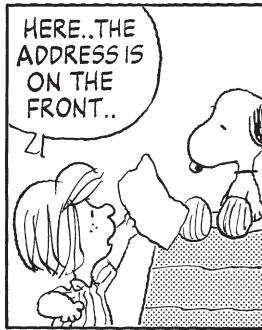
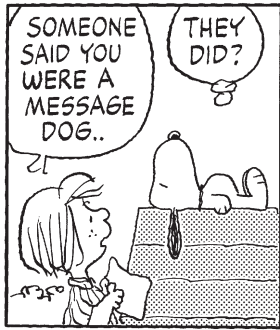

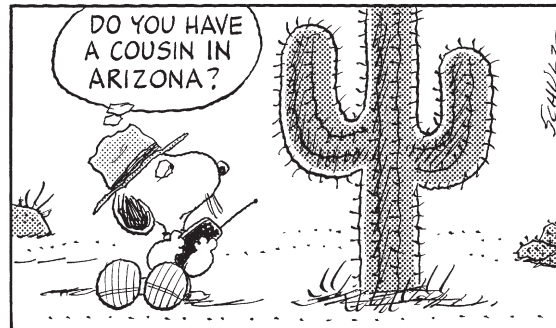
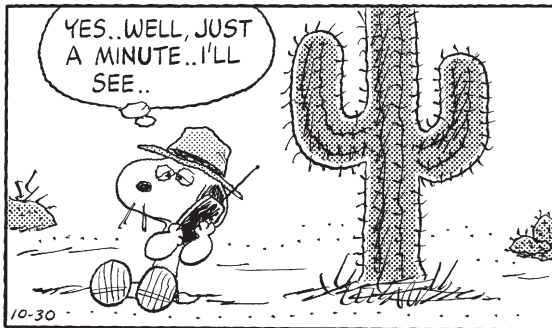
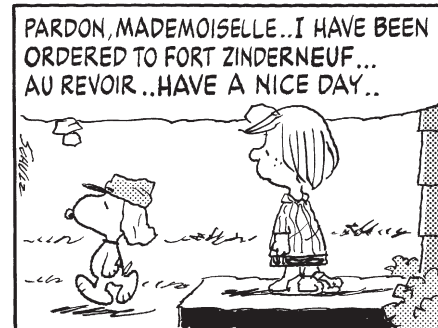
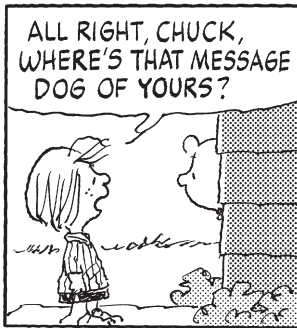

PEANUTS

by
SCHULZ

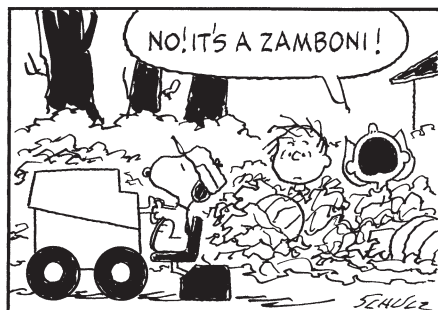
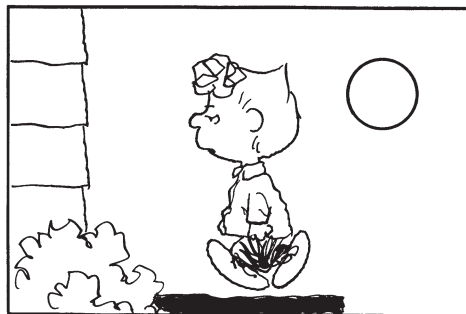

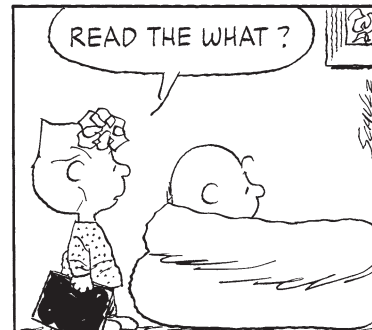
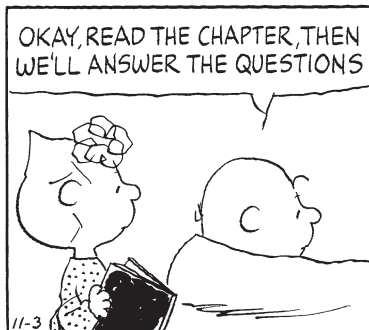
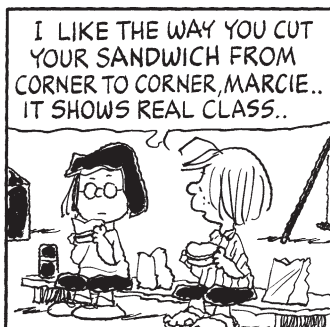
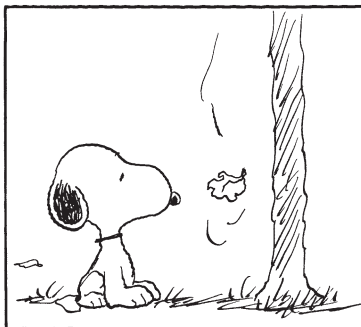

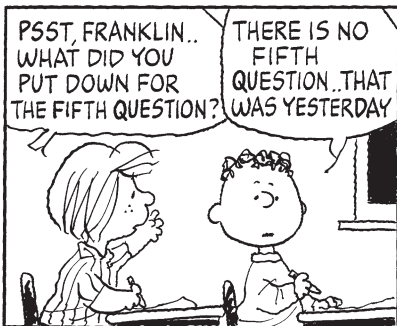
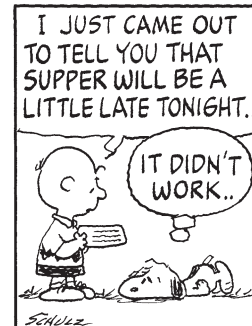
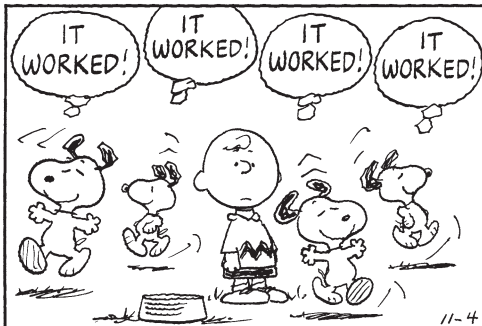

PEANUTS

by
SCHULZ

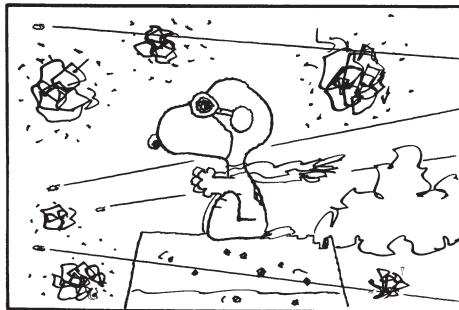
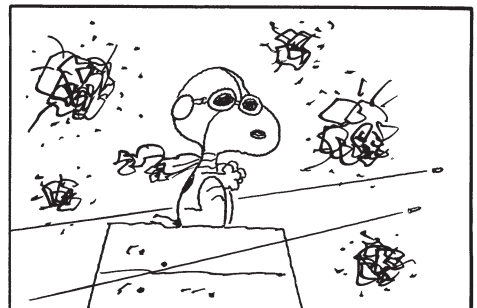
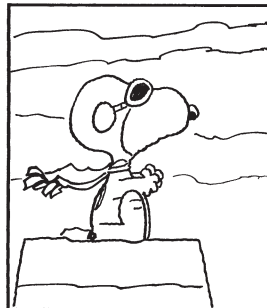
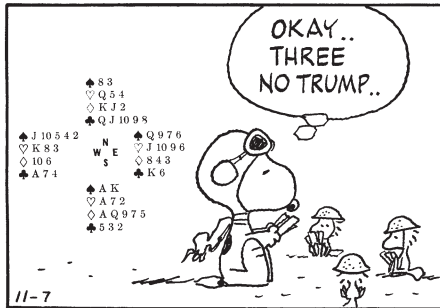
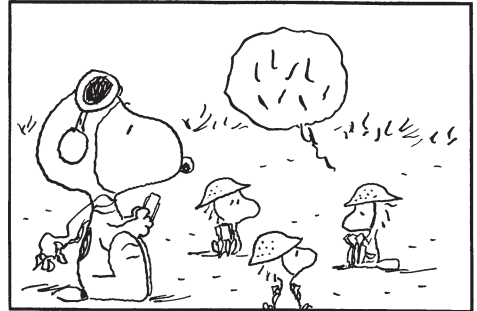
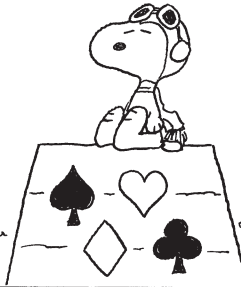

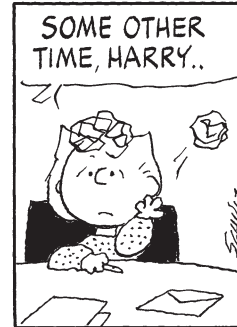
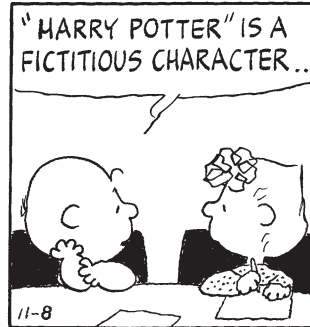
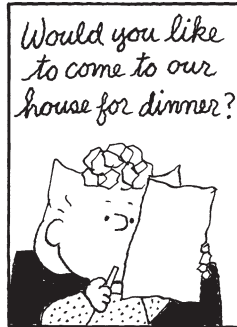
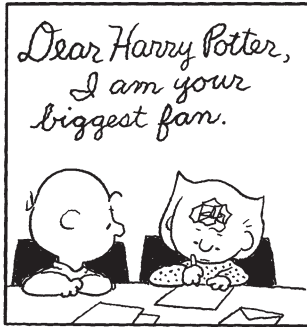

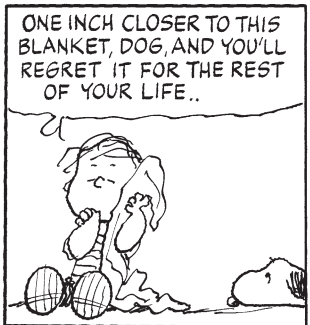
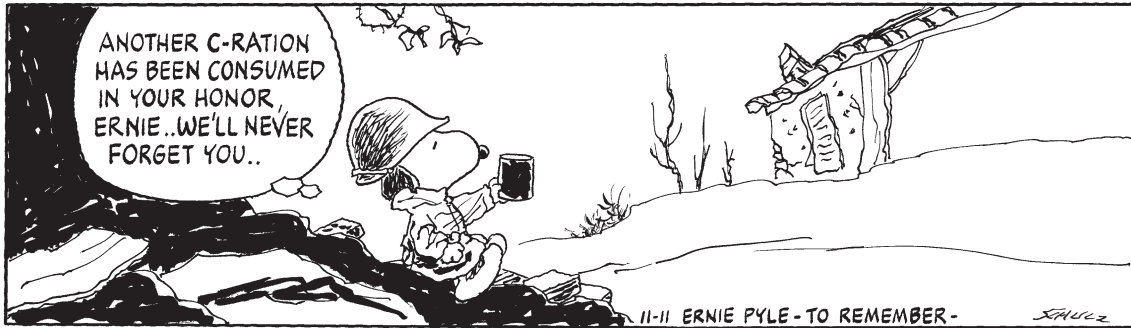

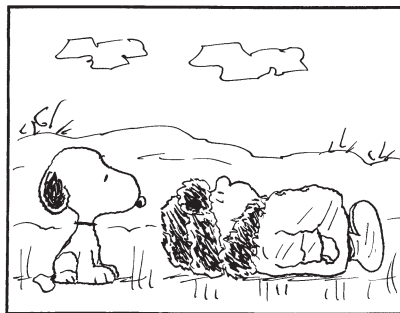
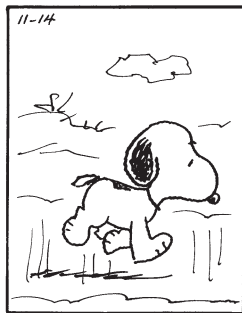
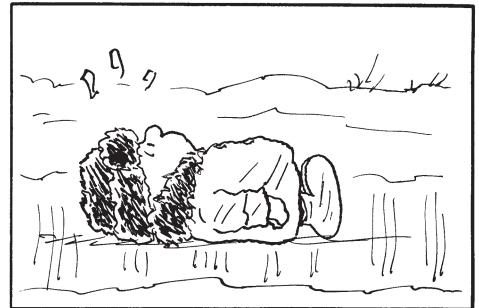
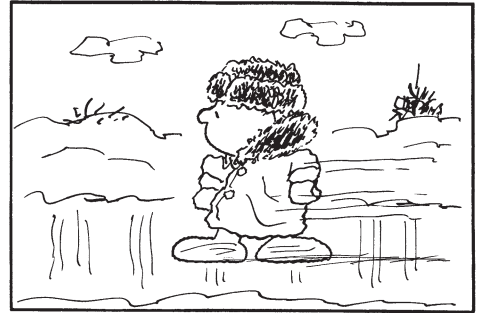
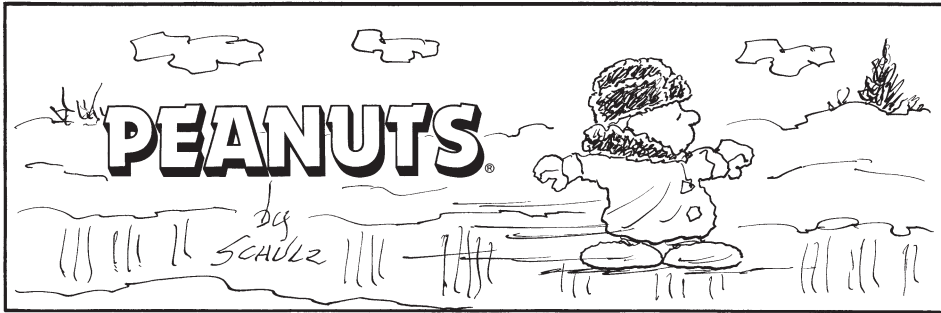

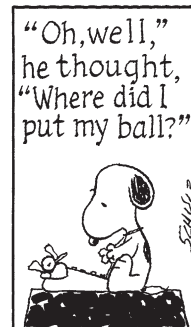
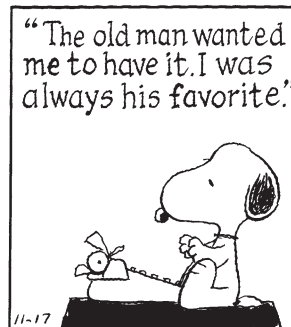
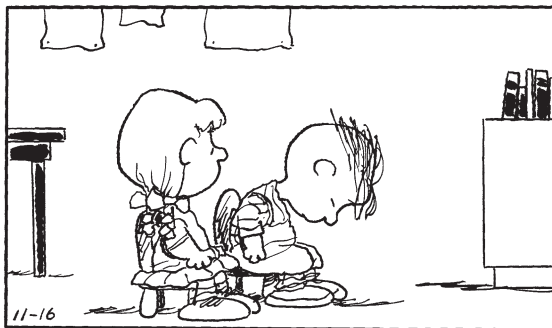
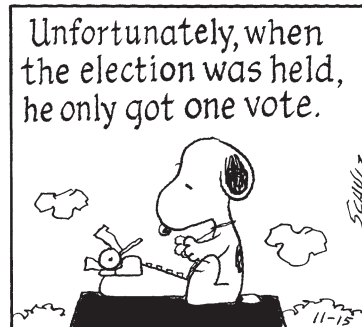
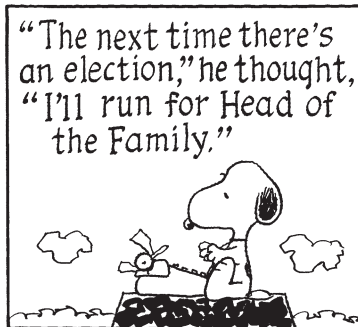

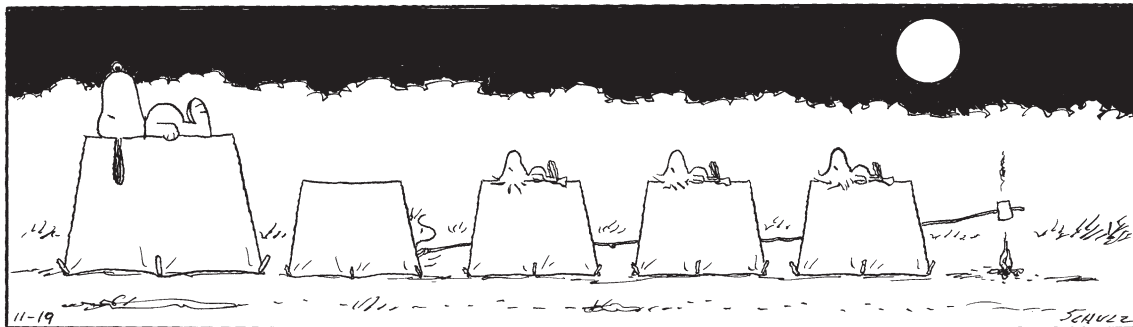
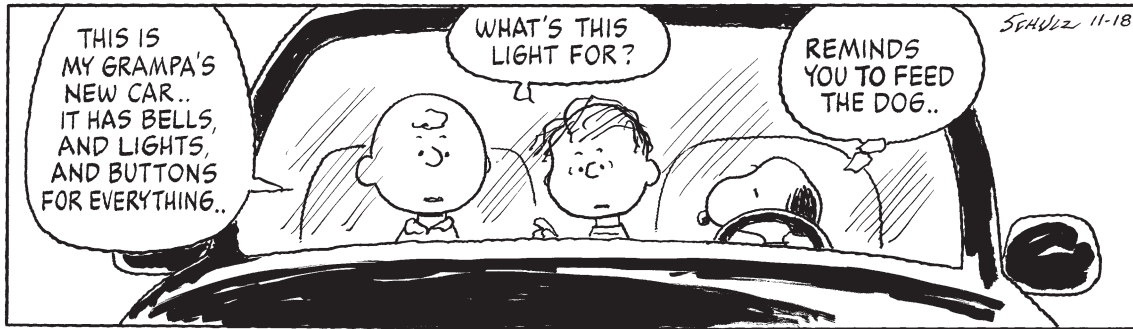

PEANUTS

by
SCHULZ

NO, I
THINK
HE'S
WRITING..

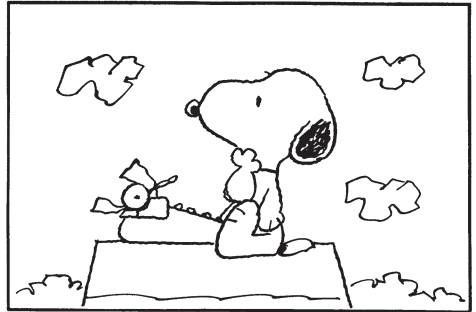
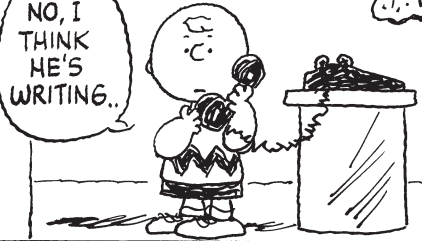

The Dog Who
Never Did
Anything



"You stay home
now," they said, "and
be a good dog."



So he stayed home,
and was a good dog.

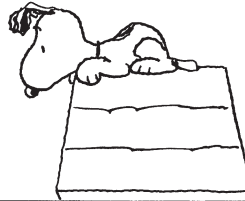

Then he decided to be even a
better dog so he barked at
everyone who went by.



And he even chased
the neighbor's cats.



"What's happened
to you?" they said.
"You used to be
such a good dog."



11-21

So he stopped barking
and chasing cats,
and everyone said,
"You're a good dog."



The moral is,
"Don't do anything,
and you'll be a
good dog."



SCHULZ

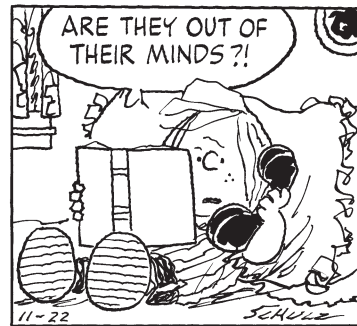
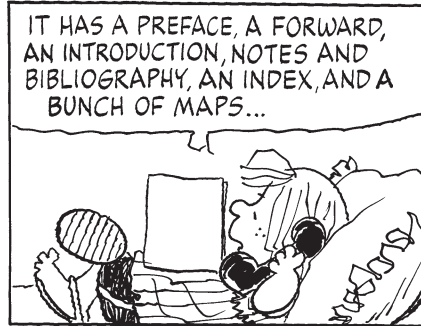

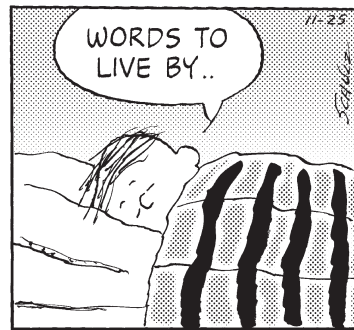

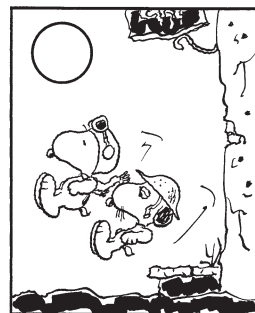
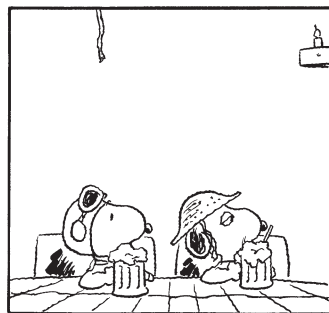
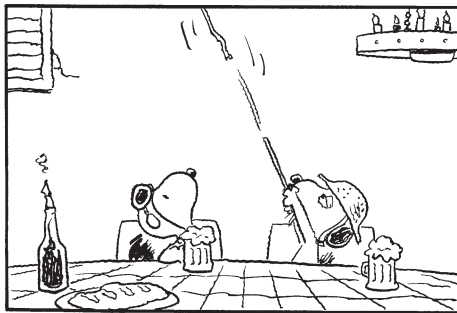
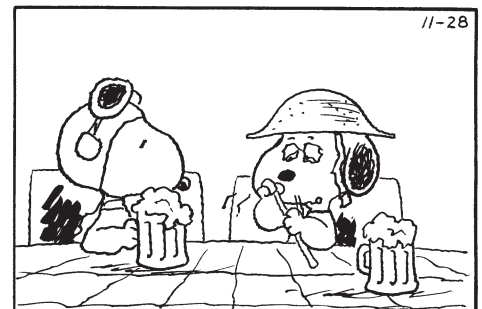
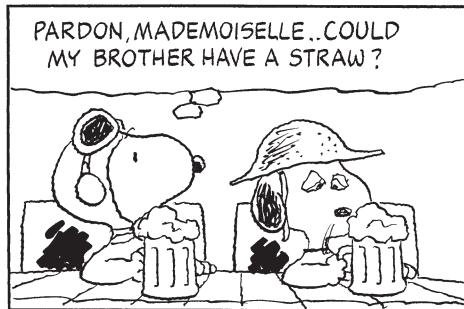
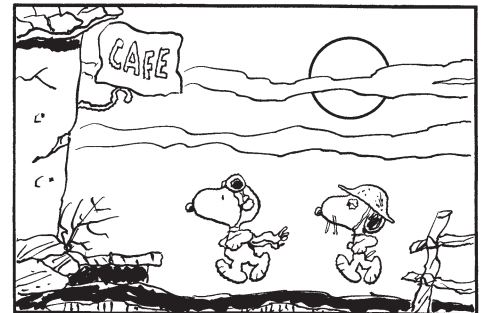
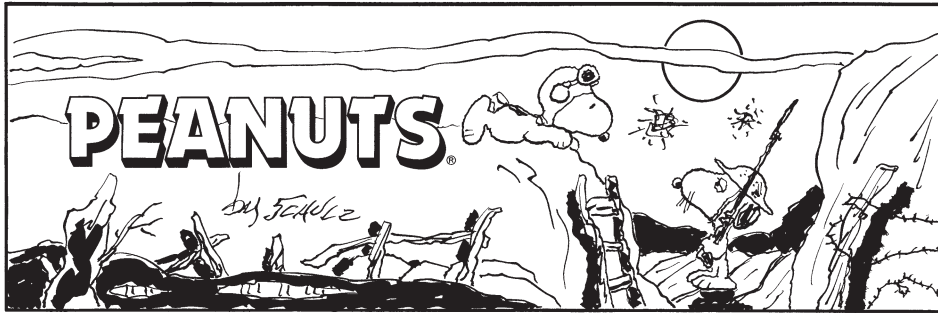

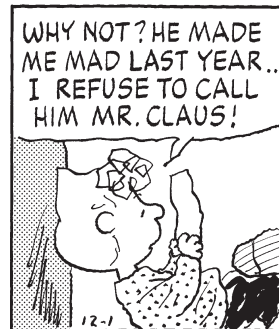
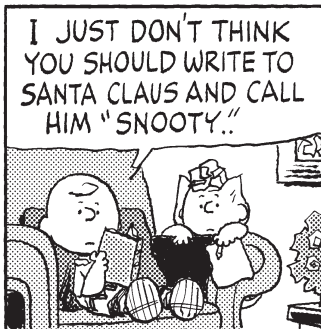
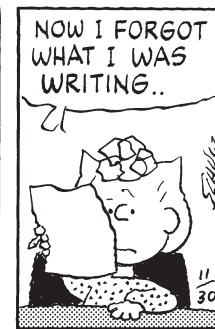
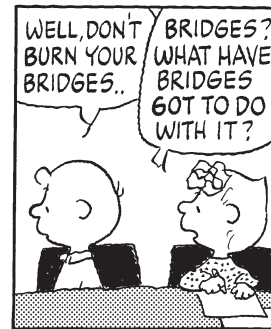
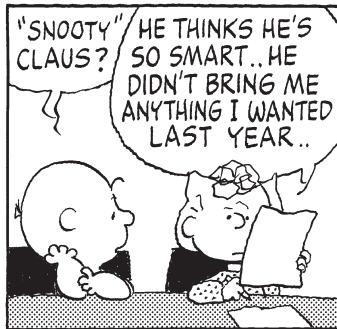
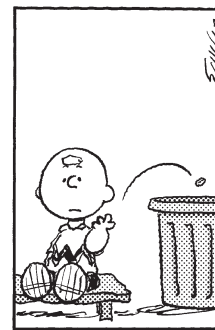

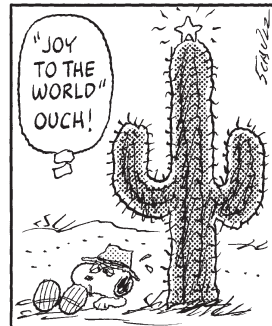
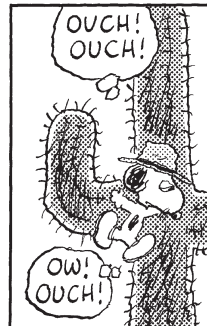
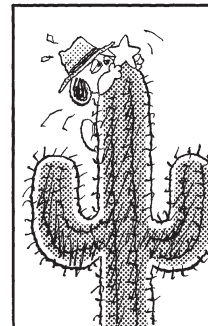
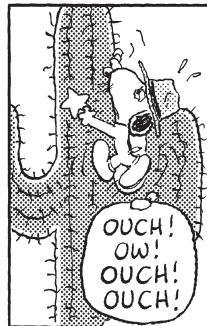
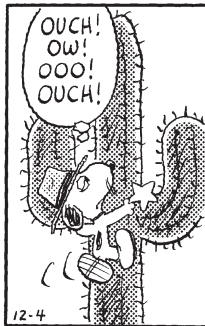
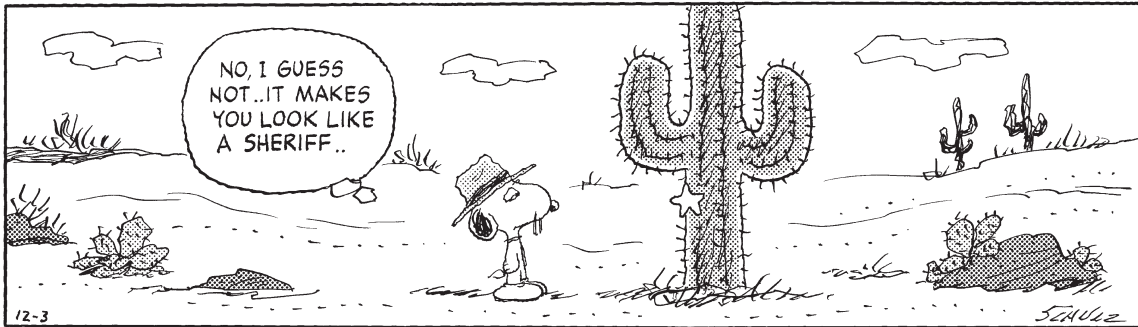
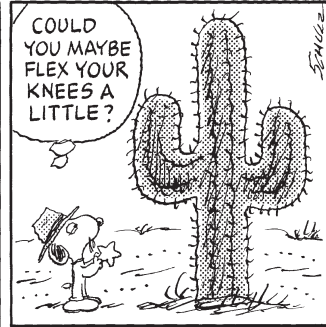
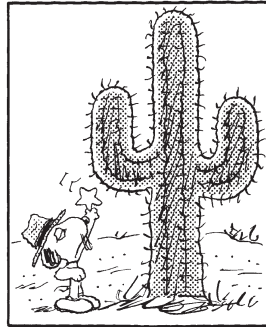

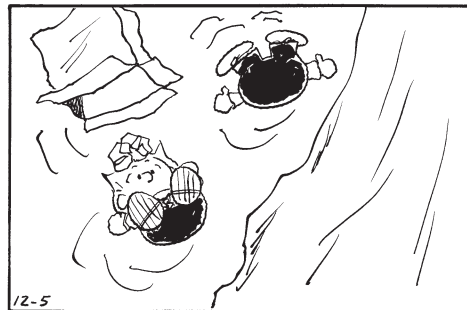
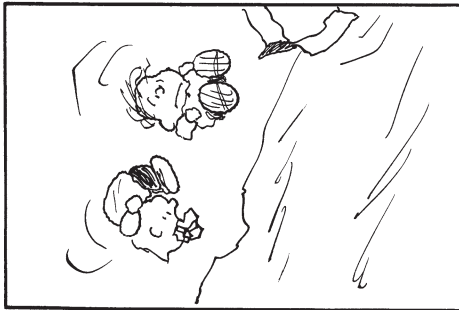
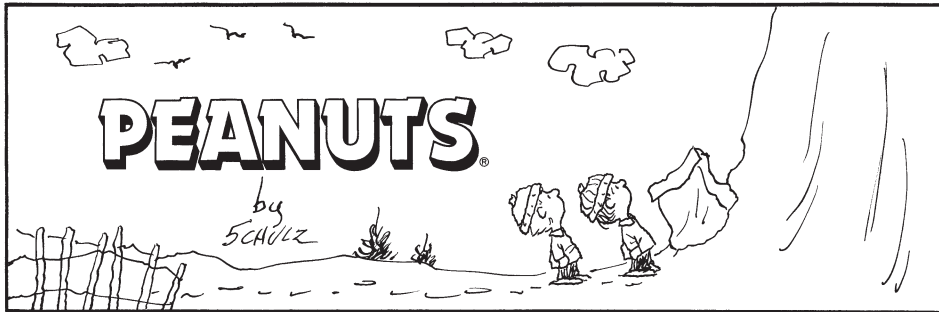

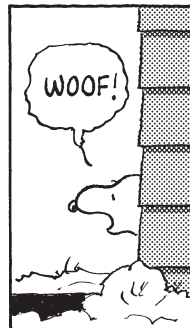
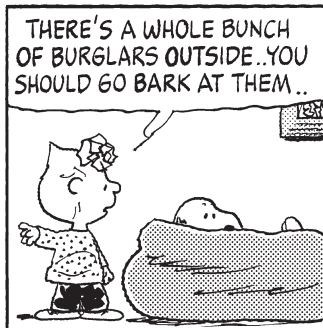
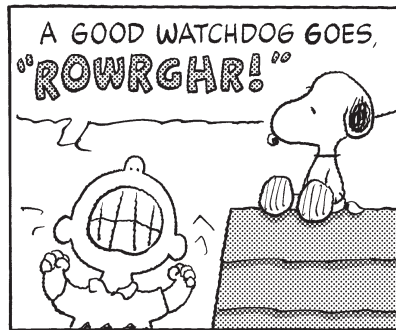
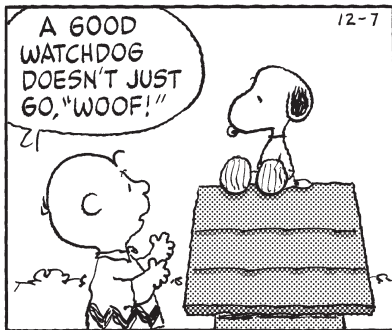
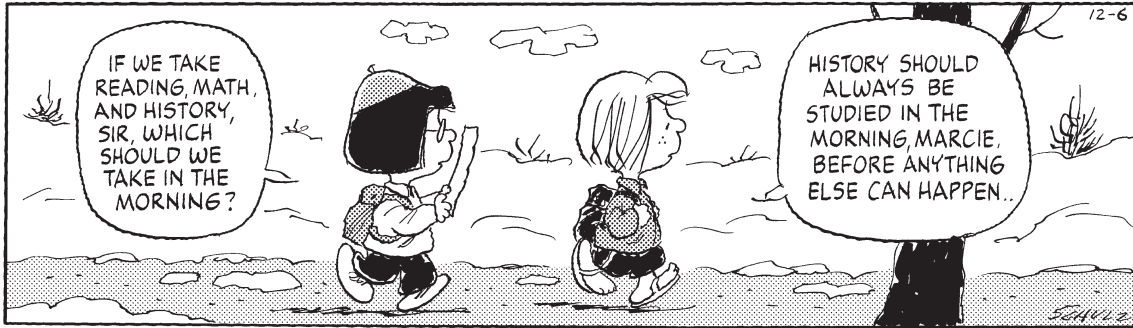

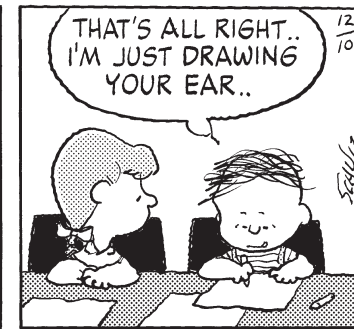
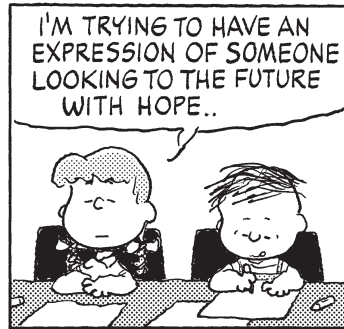
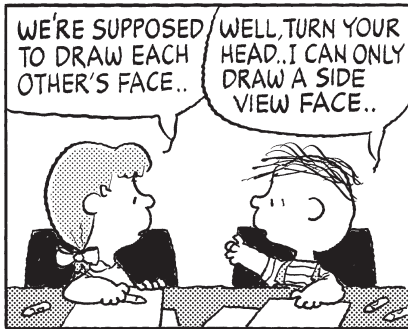

PEANUTS

by
SCAUZZ

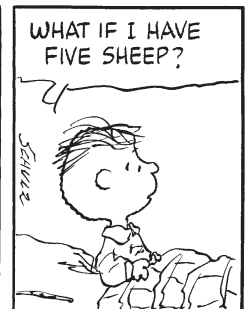
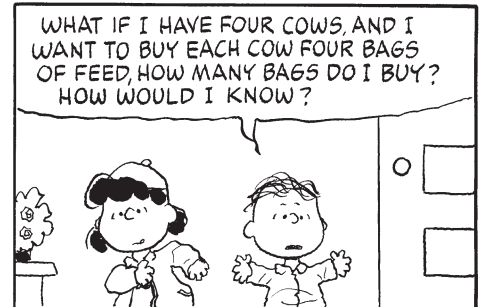
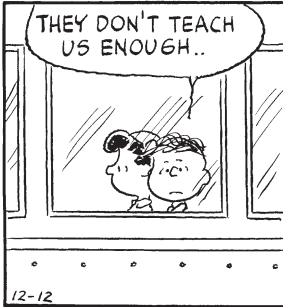
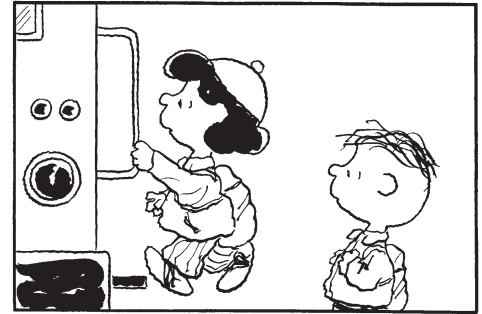
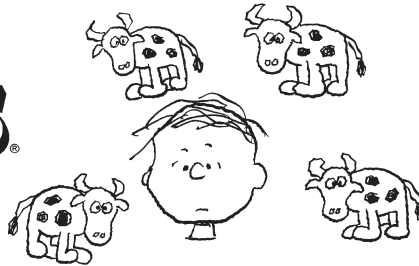

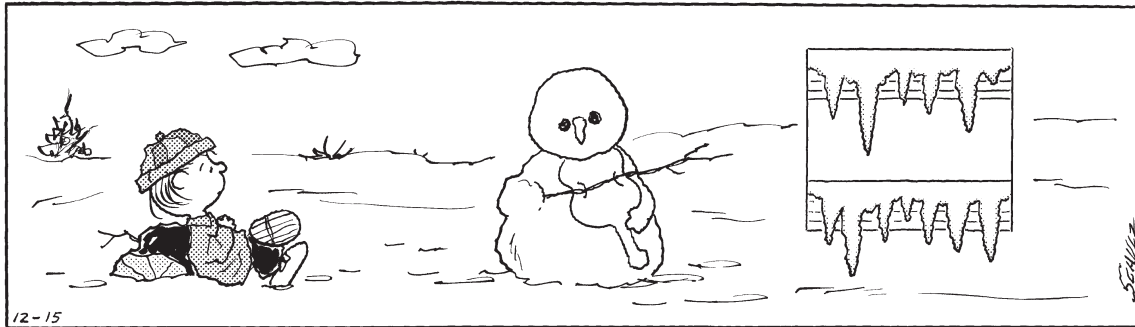
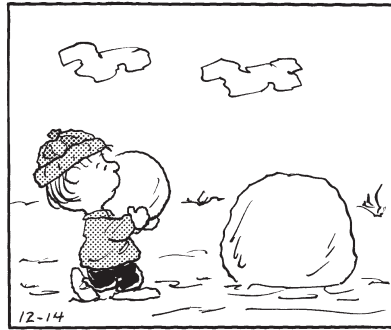
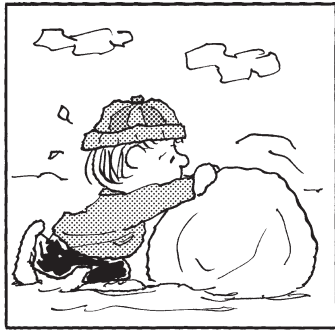

I WANT TO SEND MY TEACHER A CHRISTMAS CARD, BUT I DON'T KNOW HER NAME..



12-15

HOW CAN YOU NOT KNOW HER NAME? DON'T YOU EVER TALK TO HER?



12-15

WHEN SHE CALLS YOUR NAME IN CLASS, WHAT DO YOU SAY?



12-15

"WHO, ME?"



12-16

Two people and a dog walking through the snow.



12-17

She removed one of her mittens, and placed her hand in his.



12-17

He touched her cheek.



12-17

"Sooner or later," the dog thought, "one of them is going to forget and drop the leash."



12-17

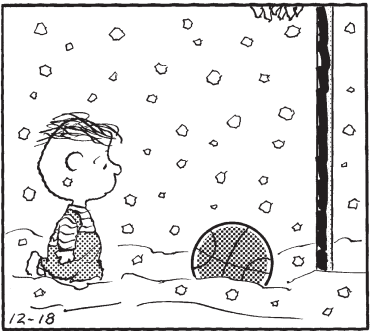

12-18

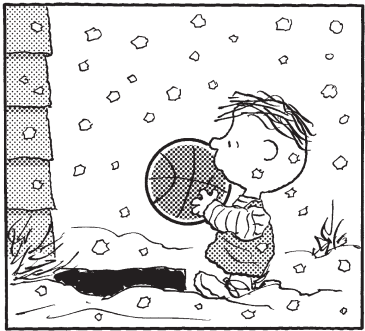

12-18

SO WHEN YOU GET OLDER, MAYBE I'LL TAKE YOU TO A NICE WARM GYMNASIUM..

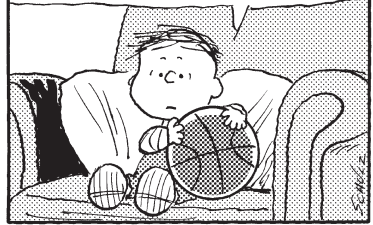

12-18

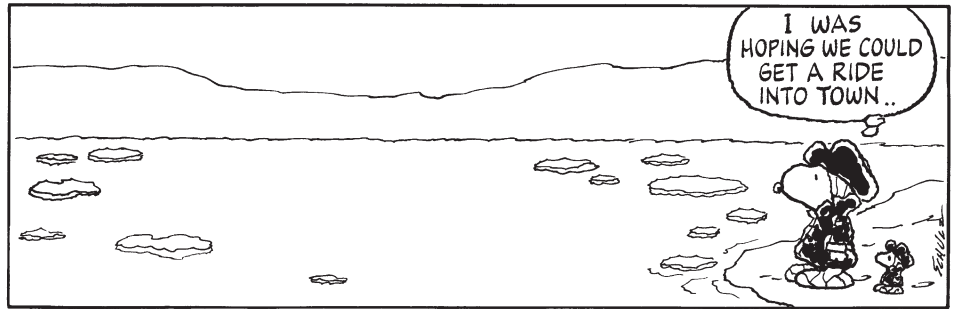
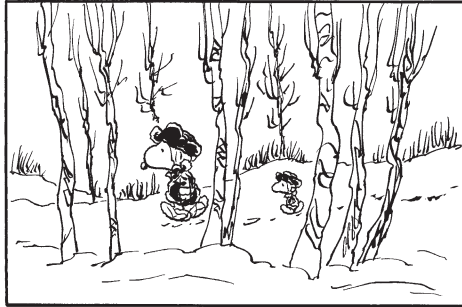
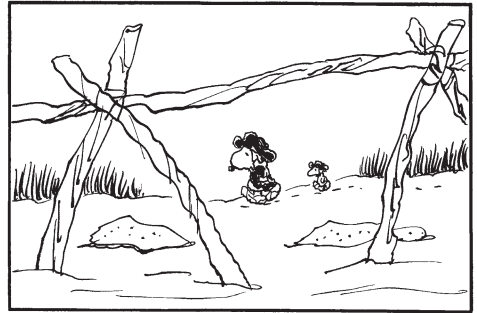
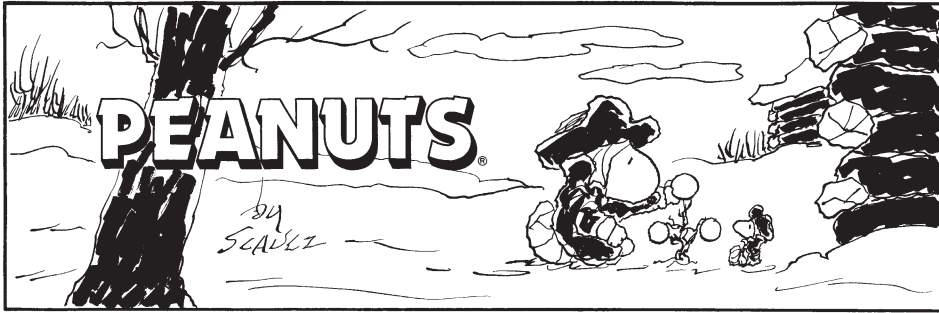

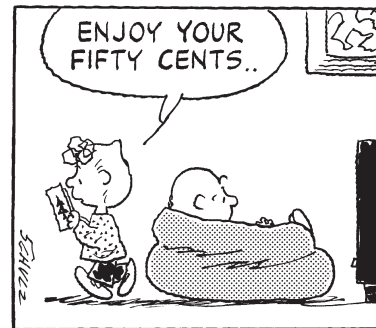
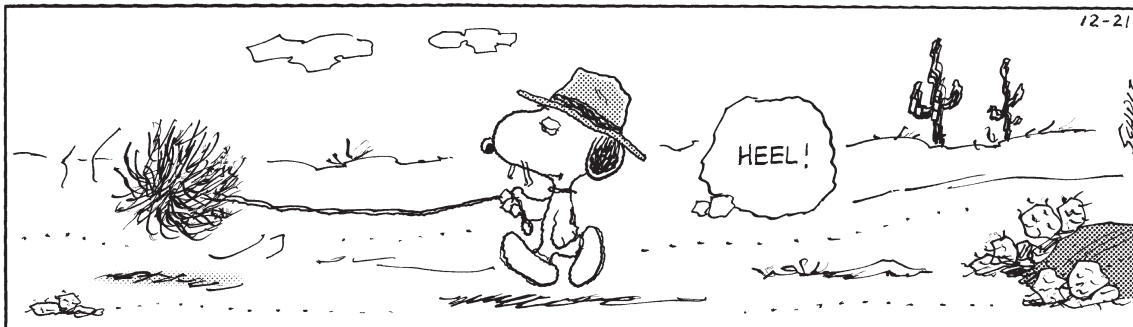

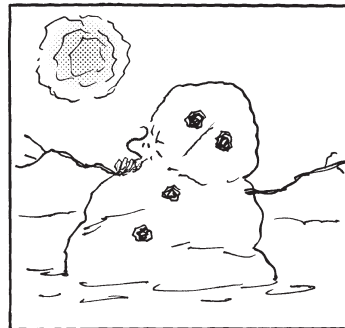
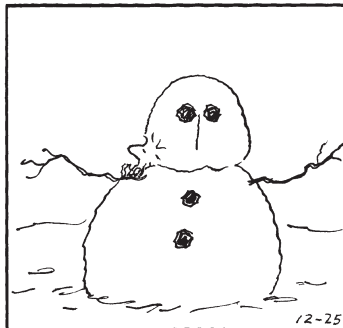
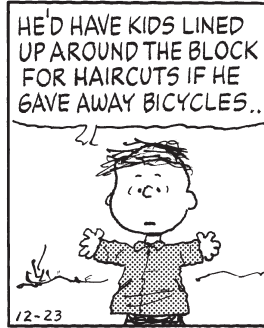

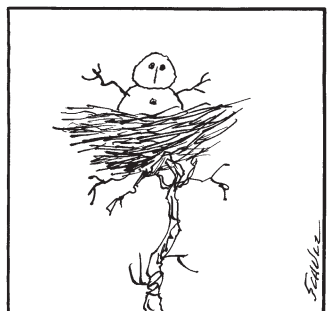
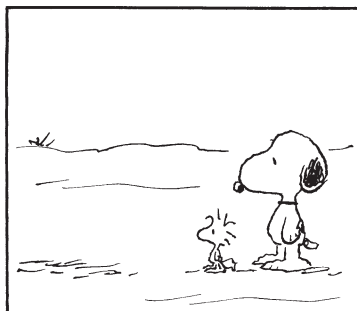
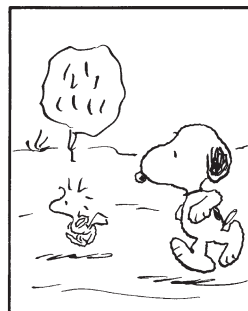
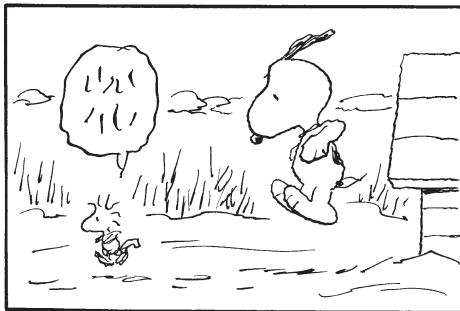
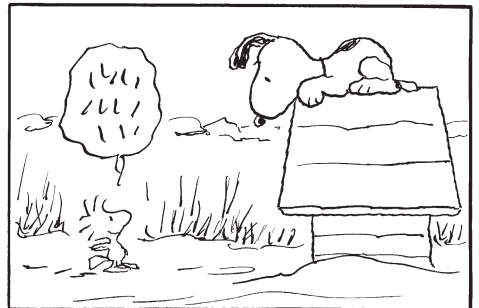
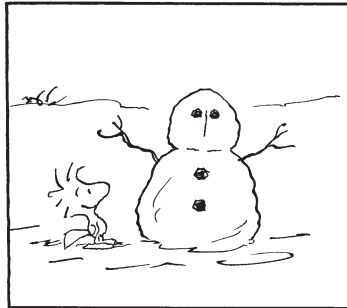
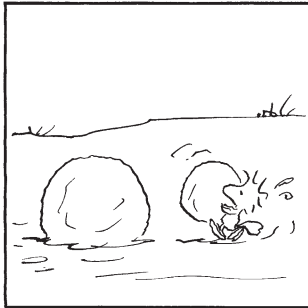
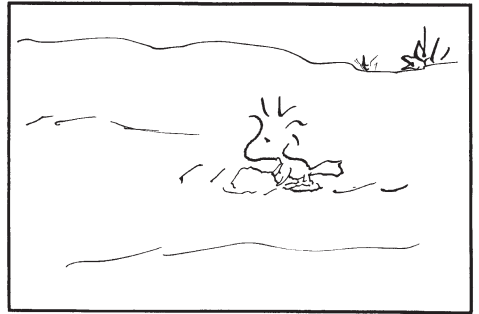
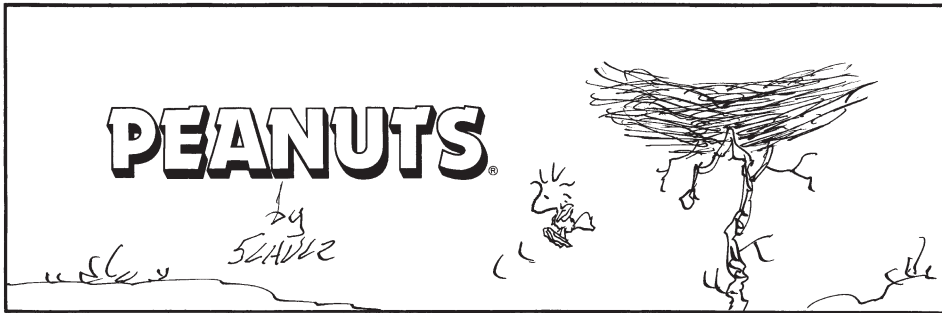

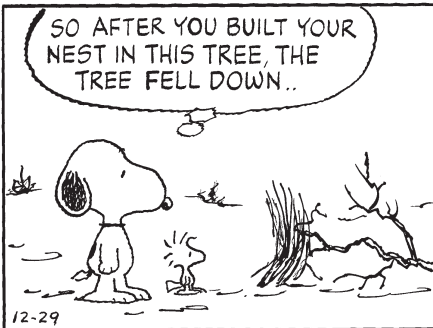
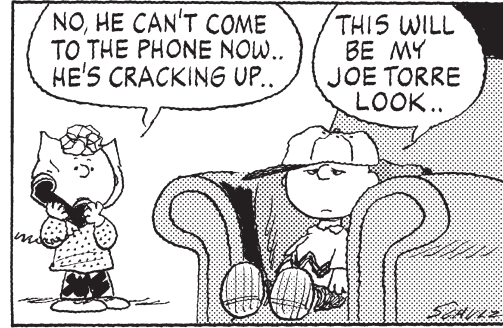

SOMETIMES IF YOU SIT IN THE RAIN, A RICH LADY WILL COME BY IN A LIMOUSINE AND TAKE YOU HOME..



RICH LADIES IN LIMOUSINES DON'T DRIVE THROUGH OUR BACK YARD..



12-30

IF YOU SIT OUT FRONT BY THE CURB, THEY SPLASH WATER ALL OVER YOU..



SCHULZ

THAT PHONE CALL WAS FOR YOU.. I TOLD THEM YOU DON'T TAKE PERSONAL CALLS..

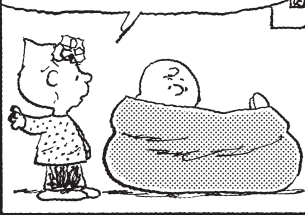

I TOLD THEM YOU LEAD A SECLUDED LIFE, AND PREFER NOT TO BE PART OF THE OUTSIDE WORLD..

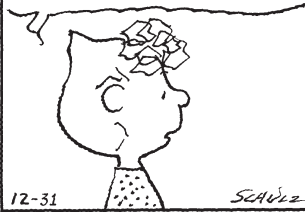

12-31

SCHULZ

I VOLUNTEERED TO BE THE ONE IN OUR FAMILY TO TAKE ALL THE PHONE CALLS..

I'D SAY SOMETHING, BUT I AM OUT OF THIS WORLD..

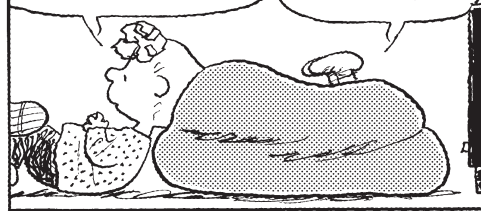

1-1-00

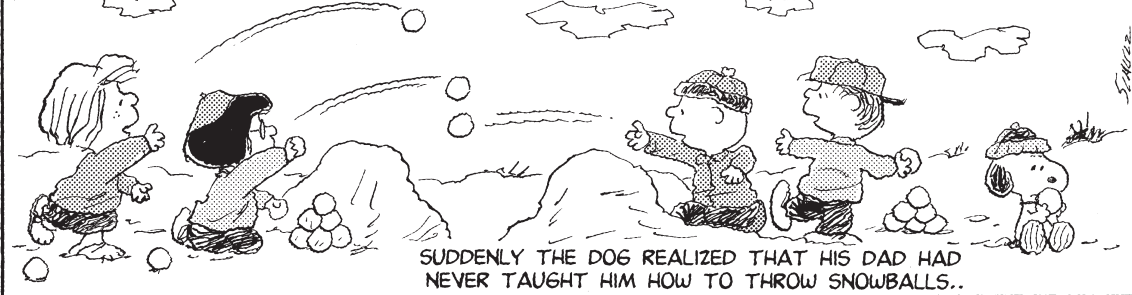

SUDDENLY THE DOG REALIZED THAT HIS DAD HAD NEVER TAUGHT HIM HOW TO THROW SNOWBALLS..

SCHULZ

PEANUTS

by
SCHULZ

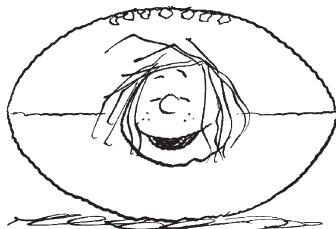

A LITTLE RAIN, A LITTLE MUD...
THIS IS WHAT IT'S ALL ABOUT..



HEY, CHUCK, IT'S
A GREAT GAME,
ISN'T IT?



WE'RE HAVING
FUN, AREN'T
WE, CHUCK?



IT'S STILL
YOUR BALL..



FOURTH DOWN..



WHAT ARE YOU
GONNA DO, CHUCK?



YOU GONNA RUN
OR PASS?



EVERYBODY'S GONE
HOME, SIR..



YOU SHOULD
GO HOME, TOO..
IT'S GETTING
DARK..



WE HAD
FUN,
DIDN'T WE,
MARCIE?



YES, SIR..WE
HAD FUN..

NOBODY
SHOOK HANDS
AND SAID,
"GOOD GAME"



PEANUTS

by
SCHULZ

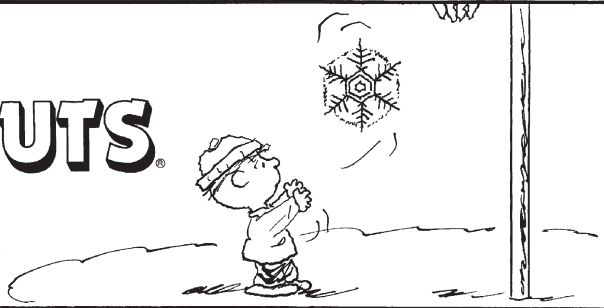

ASK YOUR DOG IF HE WANTS TO
COME OUT AND ROMP IN THE SNOW,
AND LAUGH, AND ACT LIKE WE DON'T
HAVE THE SENSE WE WERE BORN WITH..

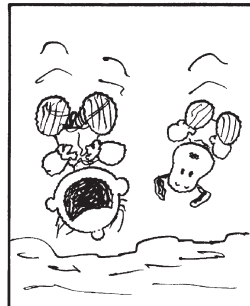
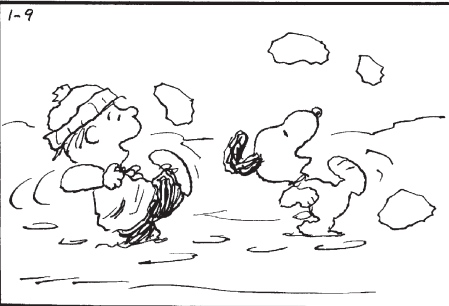
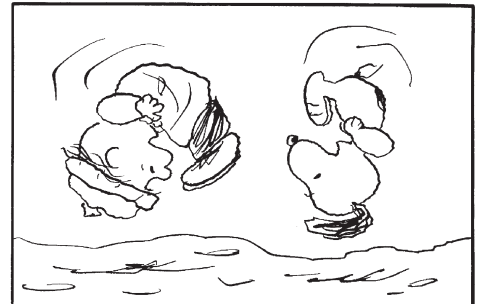
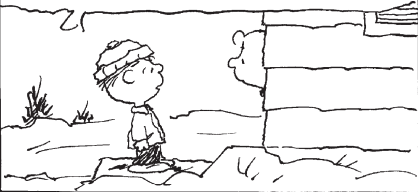

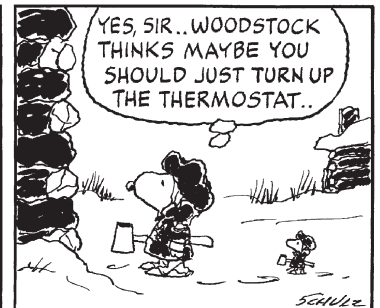
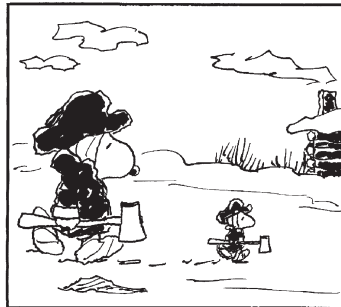
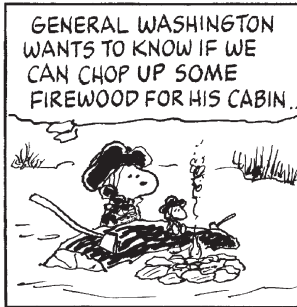
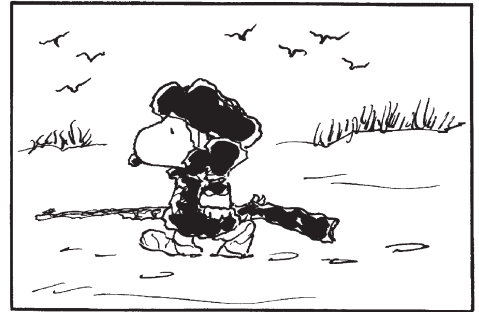
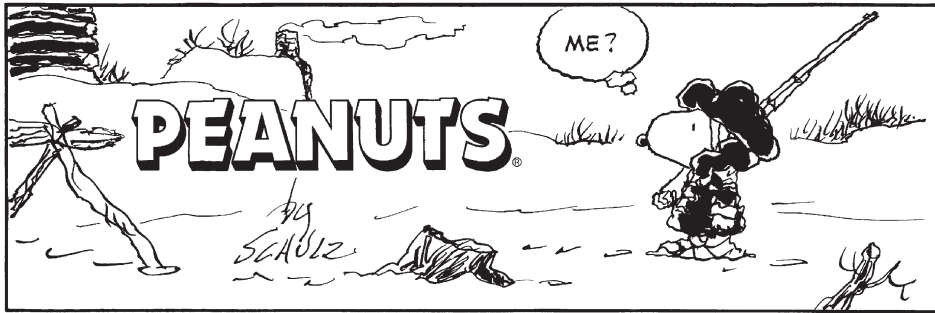

PEANUTS

by
SCHULZ

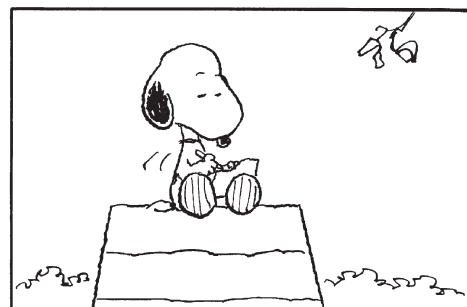
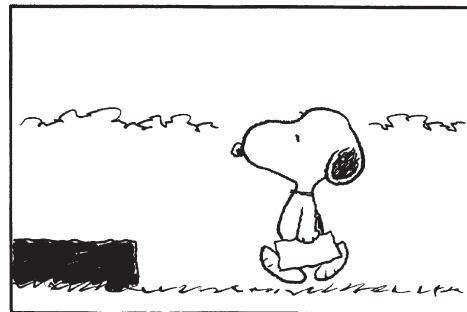

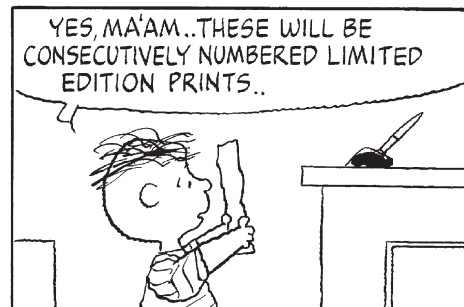
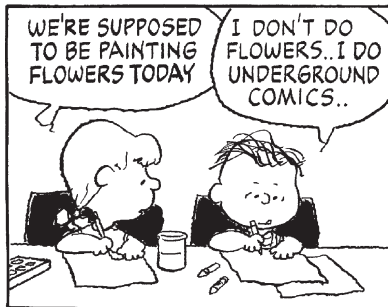
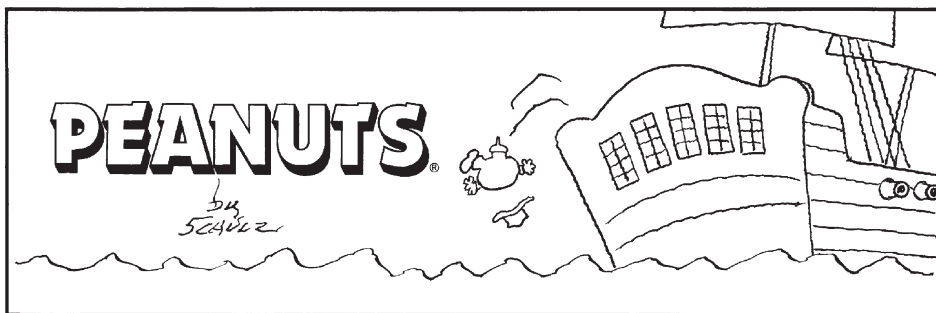

PEANUTS

by
SCHULZ

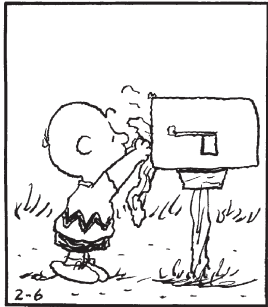
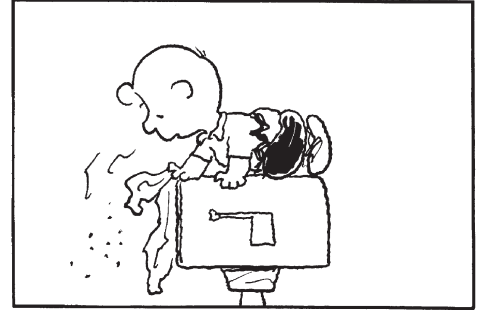
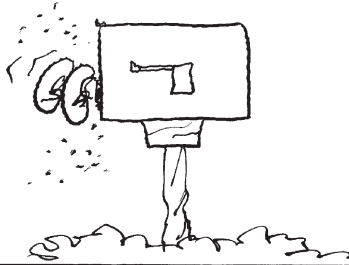

2-6

THE INSIDE OF A
MAILBOX SHOULD ALWAYS
BE KEPT CLEAN IN CASE
YOU GET A LOVE LETTER..

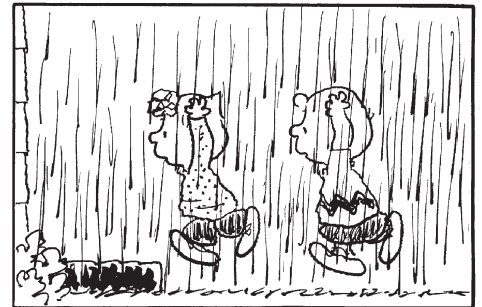
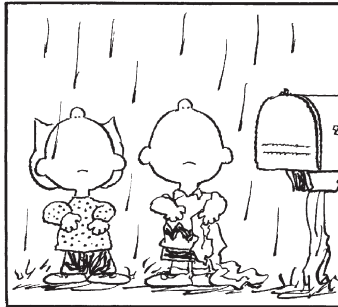
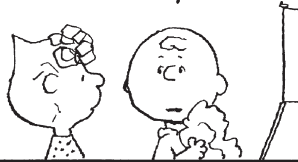

AREN'T YOU GOING OUT
TO GET THE MAIL?

NOT
WHILE IT'S
RAINING..



WHEN IT'S RAINING, THE
ONLY LETTERS YOU GET ARE
THOSE THAT SAY, "I NEVER
WANT TO SEE YOU AGAIN!"



YOU SEEM TO KNOW
A LOT ABOUT
LOVE LETTERS..



IF I EVER GOT ONE,
I DON'T KNOW
WHAT I'D DO..

SCHULZ

PEANUTS®

by
SCHULZ

NO, I
THINK
HE'S
WRITING..

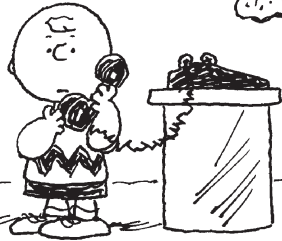

Dear Friends...



Dear Friends,

I have been fortunate to draw Charlie Brown and his friends for almost 50 years. It has been the fulfillment of my childhood ambition.

Unfortunately, I am no longer able to maintain the schedule demanded by a daily comic strip. My family does not wish Peanuts to be continued by anyone else,

therefore I am announcing my retirement.

I have been grateful over the years for the loyalty of our editors and the wonderful support and love expressed to me by fans of the comic strip.

Charlie Brown, Snoopy, Linus, Lucy...how can I ever forget them...

Charles M. Schulz

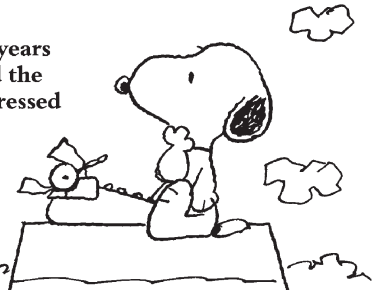

2-13-00

Dear Friends,

I have been fortunate to draw Charlie Brown and his friends for almost 50 years. It has been the fulfillment of my childhood ambition.

Unfortunately, I am no longer able to maintain the schedule demanded by a daily comic strip, therefore I am announcing my retirement.

I have been grateful over the years for the loyalty of our editors and the wonderful support and love expressed to me by fans of the comic strip.

Charlie Brown, Snoopy, Linus, Lucy...how can I ever forget them....

Charles M. Schulz

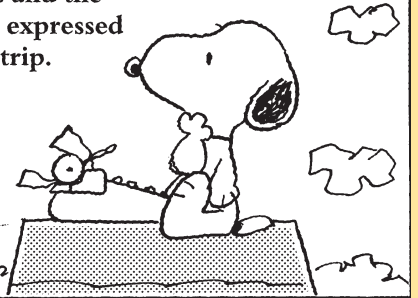

1-3-00

Charles Schulz died on the evening of February 12, 2000, mere hours before his final *Peanuts* strip ran the following day in over 2600 newspapers in 75 countries and was read by over 350 million people.

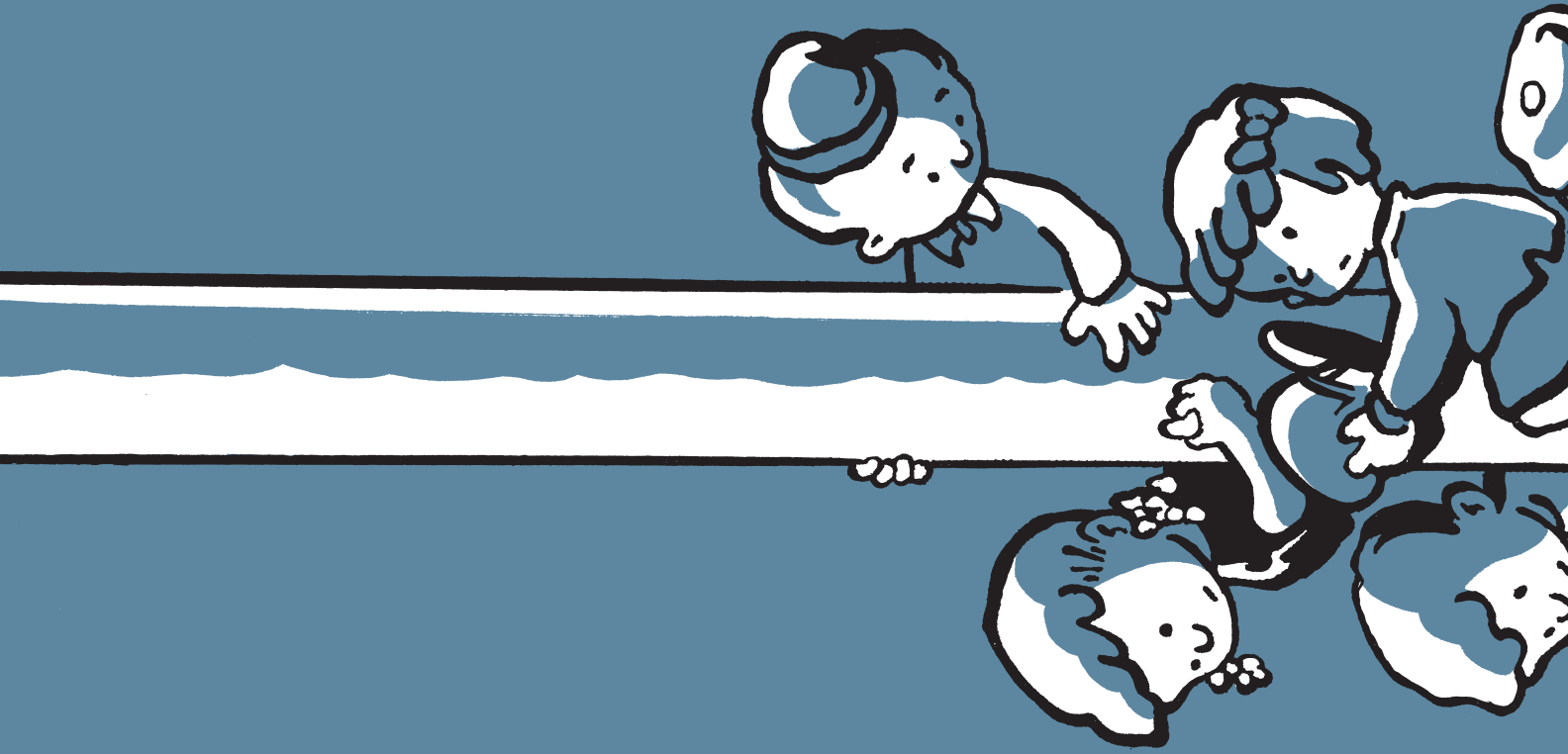

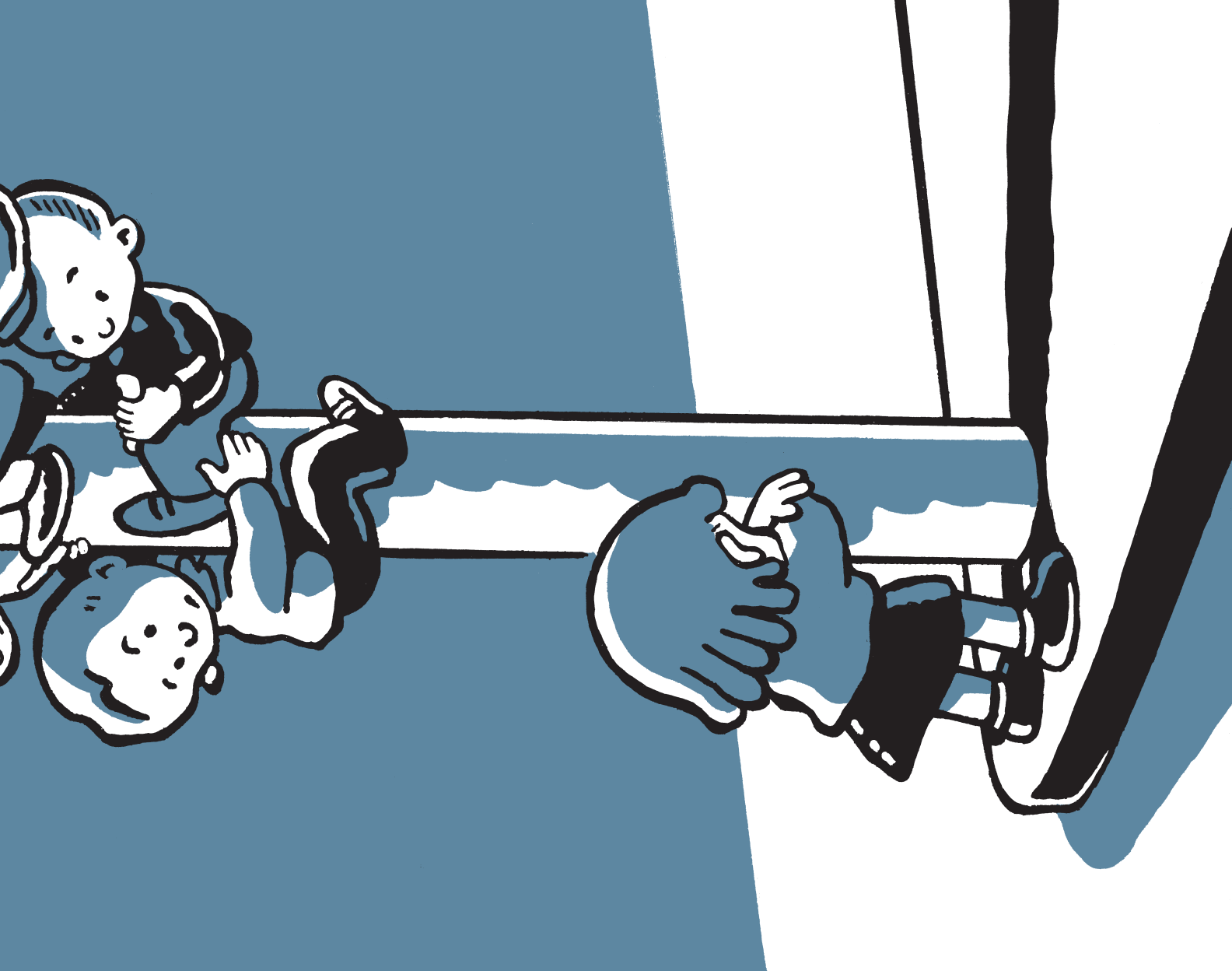

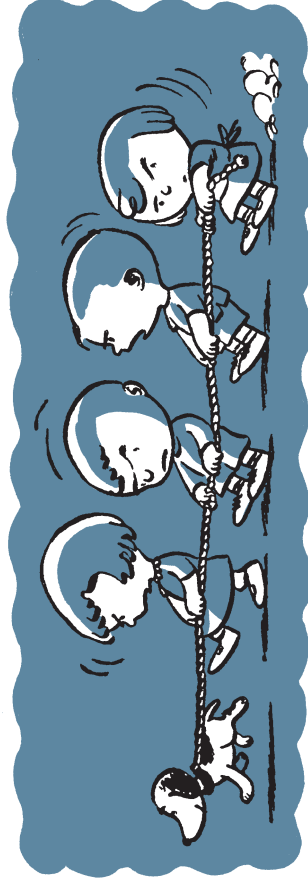

The *Peanuts* comic strip did not erupt full-blown from the mind of Charles Schulz on October 2, 1950. *Peanuts*, with its growing cast of characters and its recurring and evolving themes, was the result of Schulz's lifelong fascination with the comics form. He spent more than a decade of long hours and intense work obsessively learning every aspect of the craft of cartooning — from lettering to drawing to rendering to gag humor.

In 1946, Schulz was working at Art Instruction, Inc., an art correspondence school in Minneapolis, and submitting gag cartoons to the magazine market. He got his first big break with *Li'l Folks*. But even before *Li'l Folks*, he sold *Just Keep Laughing*... to a comic book called *Topix*, published by the Catechetical Guild Educational Society. *Topix* published two installments, Schulz said, but "the priest who was running the outfit didn't care for those, so that was the end of that."

But *Just Keep Laughing*... led to *Li'l Folks*: "One of the [*Just Keep Laughing*...] cartoons showed a small boy who looked prophetically like Schroeder sitting on the curb with a baseball bat in his hands talking to a little girl who looked prophetically like Patty. He was saying, 'I think I could learn to love you, Judy, if your batting average was a little higher.' Frank Wing, my fellow instructor at Art Instruction, said, 'Sparky, I think you should draw more of those little kids. They are pretty good.' So I concentrated on creating a group of samples and eventually sold them as a weekly feature called *Li'l Folks* to the *St. Paul Pioneer Press*."

Li'l Folks, a weekly gag feature composed of three or four independent panels, ran on the women's page. Schulz was paid \$10 per installment for writing and drawing it. After two-and-a-half years, he asked for a better location in the newspaper. He was told no. He asked to appear daily. No, again. Finally, he asked for a raise. No.

"When he turned me down on all three counts," Schulz said, "I suggested that perhaps I had better quit. He merely said, 'All right.' Thus endeth my career at the *St. Paul Pioneer Press*." *Li'l Folks* ran from June 22, 1947 to January 22, 1950.

Li'l Folks is the most fully realized creative antecedent to *Peanuts*, which, in Schulz's own words, "gave me a chance to develop my drawing and my creativity." One can see Schulz's cartoon universe taking shape throughout the *Li'l Folks* run. The gag panels included a genteel child pianist/violinist who loved Beethoven, a goofy little dog, a boy named Charlie Brown (the name of one of Schulz's fellow teachers at Art Instruction), the theme of unrequited love, an ongoing tension between boys and girls, and the conspicuous absence of adults. Speaking about *Li'l Folks* in 1987, Schulz commented, "Some of them are pretty good. I look at them, and they were all right, but it was a growing process." In fact, it grew into *Peanuts*.

For ten months after the last appearance of *Li'l Folks*, Schulz tried to sell it to a newspaper syndicate, finally submitting his proposal to United Feature Syndicate.

In order to increase his chances of selling the strip, he offered a second format option: he expanded the single-panel gags into a daily continuity strip, an exercise that certainly taught him about the visual rhythms of sequential storytelling.

When he visited the syndicate's offices, Schulz said, "I had brought along a new comic strip I had been working on rather than the panel cartoons which United Feature Syndicate had seen [earlier]. I wanted to give them a better view of my work. They decided they would rather publish the strip than the panel. That made me very happy, for I really preferred the strip to the panel."

That single editorial decision in 1950 gave a young cartoonist the artistic latitude he needed to create one of the most phenomenal comic strips of all time.

This volume of *The Complete Peanuts* prints the last *Peanuts* strip that Charles Schulz drew. It is appropriate now, as we come full circle, to also present *Li'l Folks*, the cartoon strip that immediately presaged *Peanuts* and started it all.

—Gary Groth

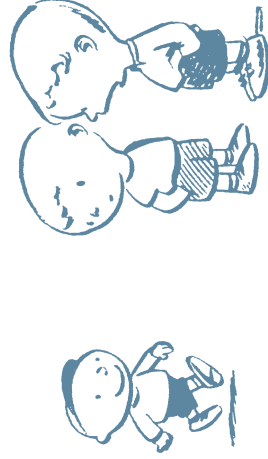

Sparky's L'il Folks



"Boy, I was almost late again . . . I had to run all the way!"

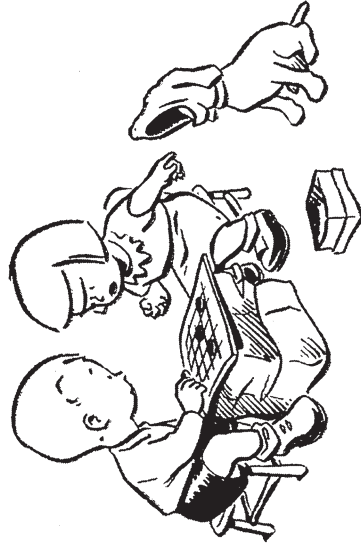

"If he yawns just once more, I'm going home!"

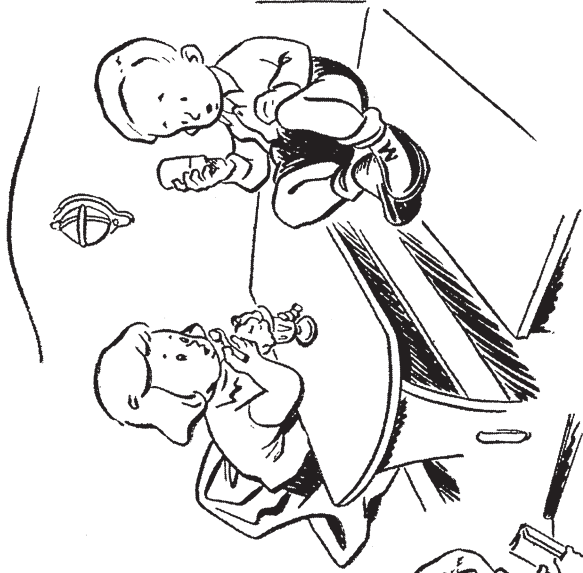

"Yes, sir, there's nothing like a good, cold drink of water."

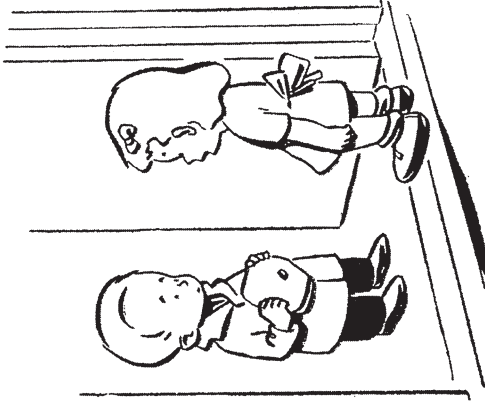

"Mom says you can come in if you'll promise not to wrestle any more with Grandma."

Sparky's Lil' Folks

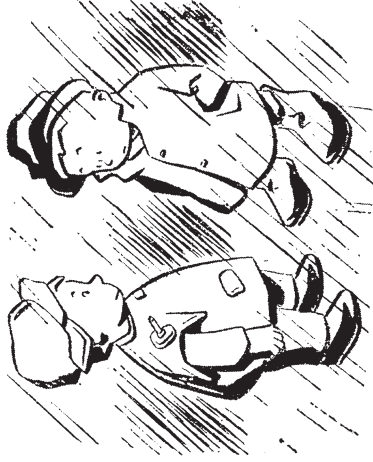

It's a pretty good raincoat even though Ma did make it out of an old innertube."

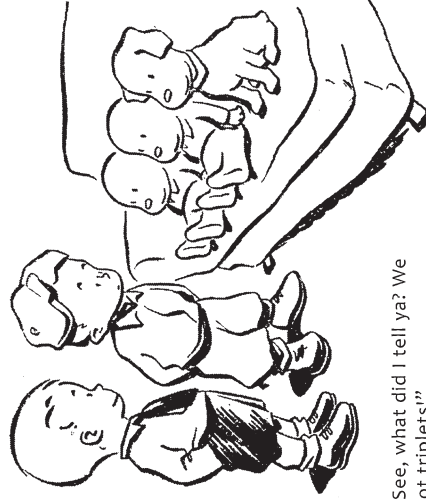

"See, what did I tell ya? We got triplets!"

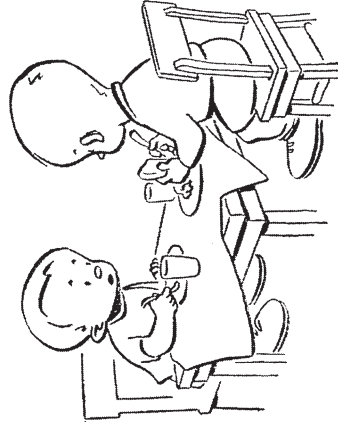
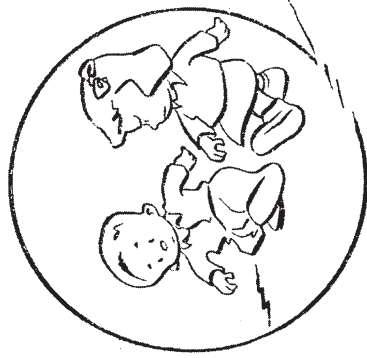

"if you don't like the meatballs, save them and we'll throw 'em at the kid next door."

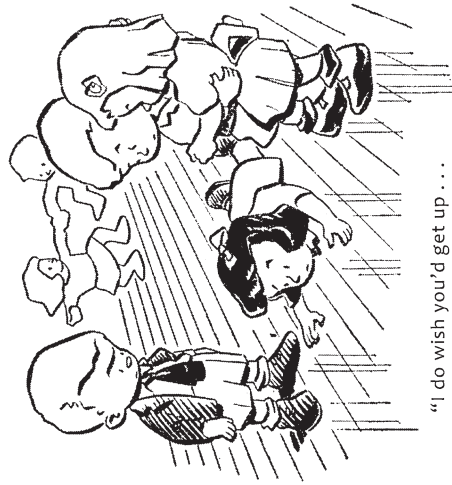

"I don't see why you have to carry all those marbles in one pocket."

"I do wish you'd get up . . . You're embarrassing me."

Lil' Folks

BY SPARKY

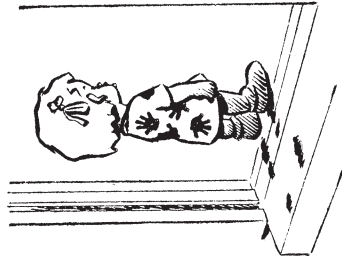

"We been playin' tag."

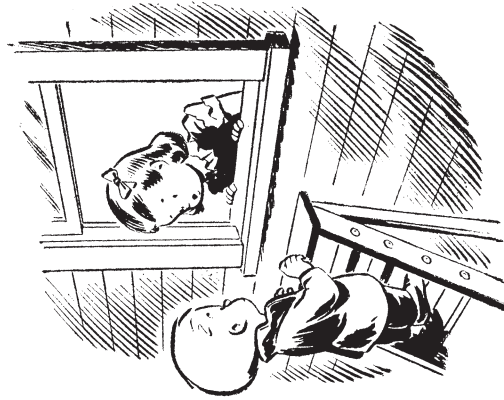

"Mom says I can't elope with you tonight . . . I've got too much homework to do."

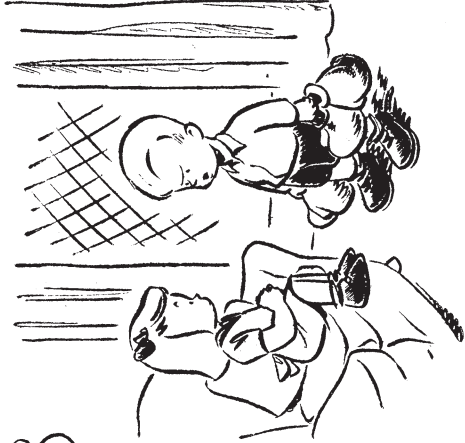

"Oh, rats, you never want to do anything."

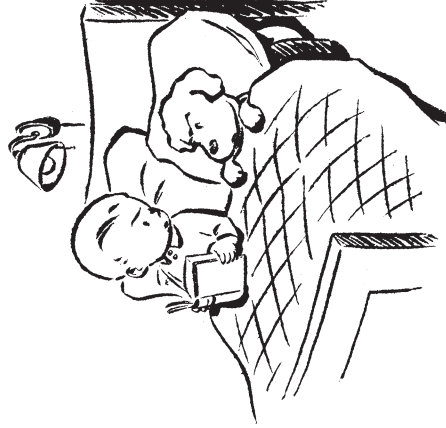

"I always read in bed so might just as well get used to it!"

Lil' Folks

BY SPARKY



"Twenty - two, eleveny - six, twelvy - four . . ."

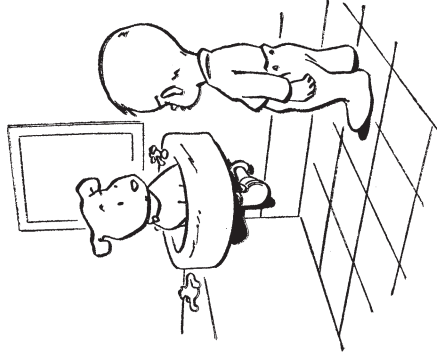

"Now look here . . . I don't care if you are scared of mice . . . you have to go to bed sometime!"

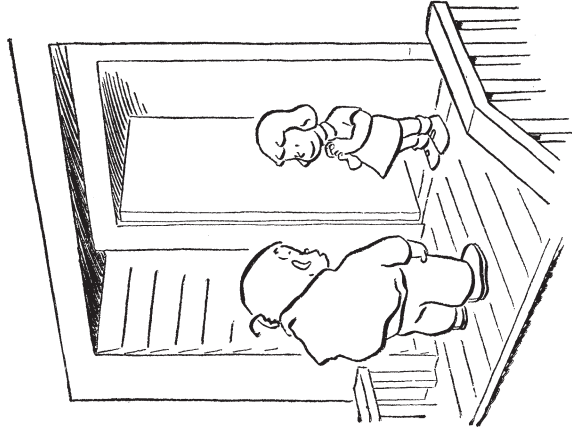

"What makes you think I get so excited over coming to see you?"

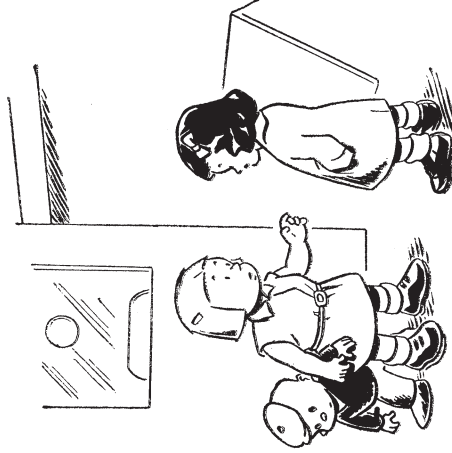

"Are you sure you can get in for twelve cents with all that lipstick on?"



Lil' Folks

BY SPARKY

"And then we'll have ice-cream, an' cake, and lots of presents for everybody so you go ask your mother if you can come."



"You might as well turn around. You're not fooling anybody!"

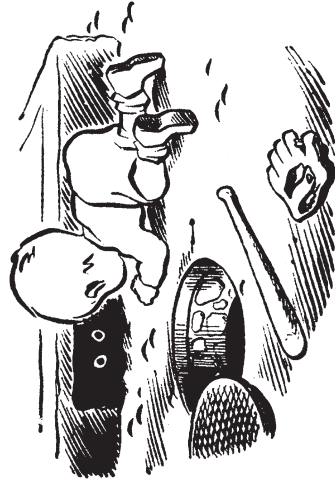

"Did you find the ball, Jimmy? . . . or aren't you Jimmy?"

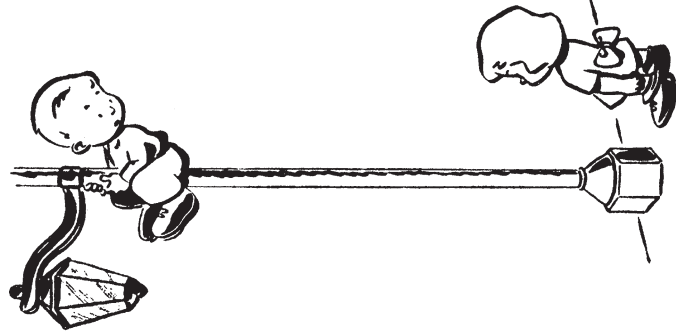

"I don't understand. . . . There's no lightswitch up here either!"

Lil' Folks

BY SPARKY

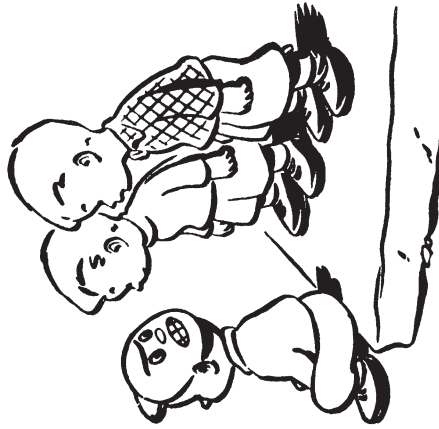

"We better lay off this guy. . . He looks plenty tough."

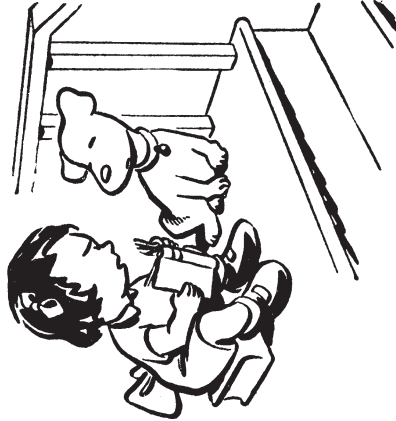
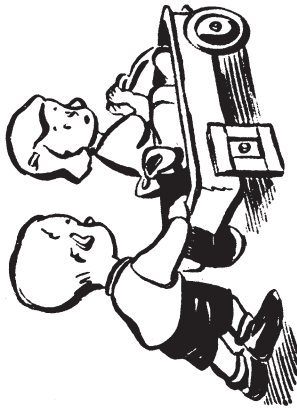

"Well, if you're gonna fall asleep all the time, I might as well stop reading."

"Y'know . . . This thing doesn't ride so well since you fixed it."



"Do you hear someone yelling?"

Lil' Folks

BY SPARKY



"Don't mind Jimmy. . . . He's sort of bashful."

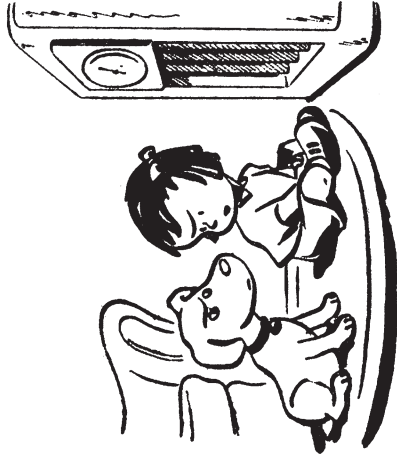

"Oh, stop looking so interested. . . . You don't even know who's talking!"

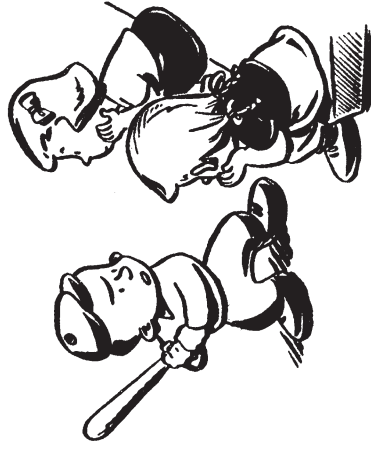

"And then I would have pitched a no-hit game, and hit three home runs, but I was too young to get in the game!"



"All right you guys. . . . Who put in the mothball?"

Lil' Folks

BY SPARKY

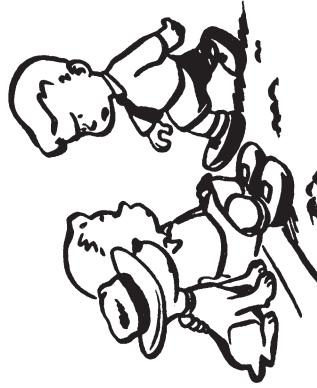

"If you're trying to make me jealous, you're wasting your time!"



"Did you ever have the feeling of impending doom?"

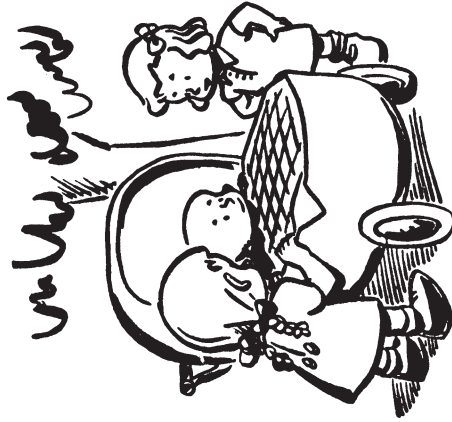

"I'm not sure, but I think we got him with cereal box-tops."

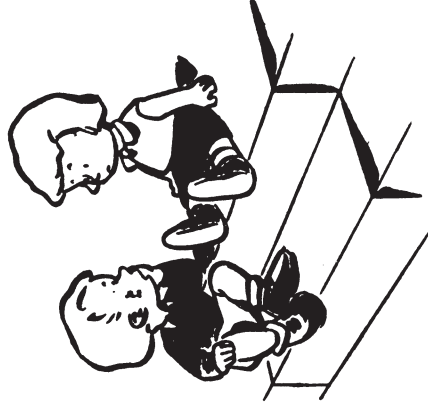

"... Your eyes... your hair... your new tricycle with the big red wheels..."

Lil' Folks

BY SPARKY

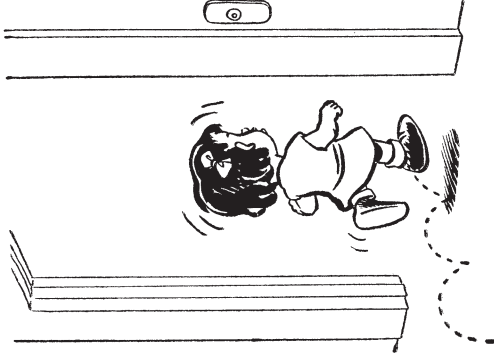

"We been playing hop-scotch."



"Well, it looks like our little game is about to come to an end!"

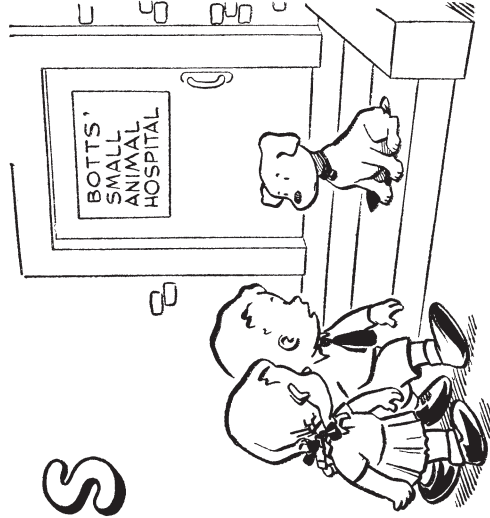

"That must be one of the interns."

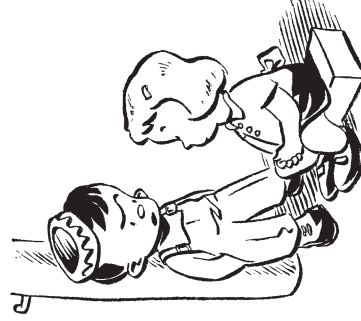

"Do you realize that I'm almost 6 years old? And what have I accomplished . . . Nothing!"

Lil' Folks

BY SPARKY

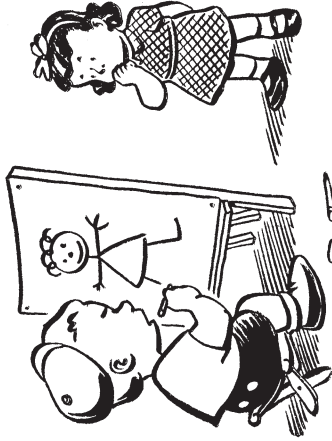

"You moved!"

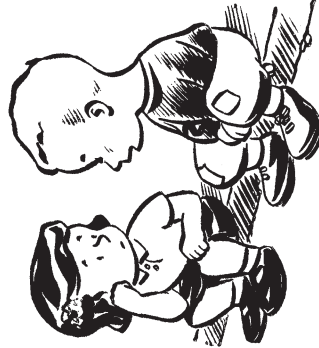

"Y'know, if you were sure that you and I were going to the same high school, I'd ask you to the senior prom."

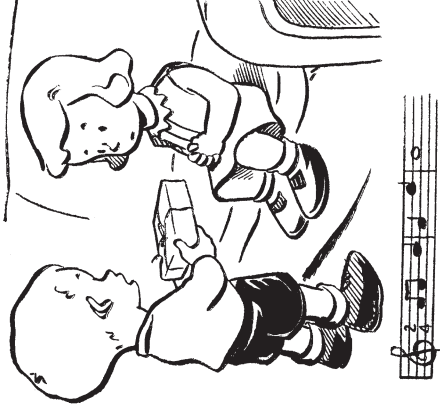

"Happy birthday to you . . .
"Happy birthday to you . . .
"Happy birthday, dear . . .
"What did you say your name was?"

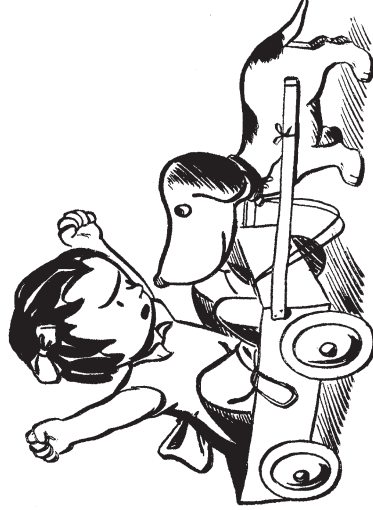

"No, no, no! . . . You don't seem to understand!"

Lil' Folks

BY SPARKY

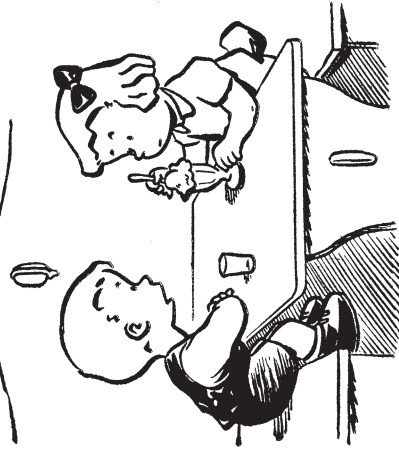

"Y' know, I've come to regard our meeting as being something almost symbolic."

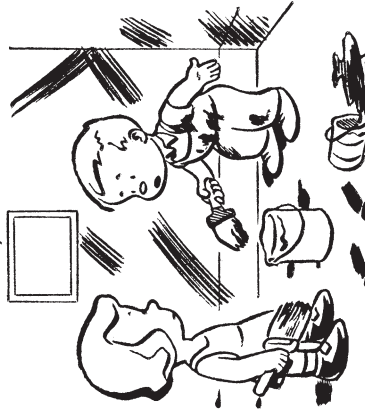

"Why should your mother get mad? I think it brightens up the place."

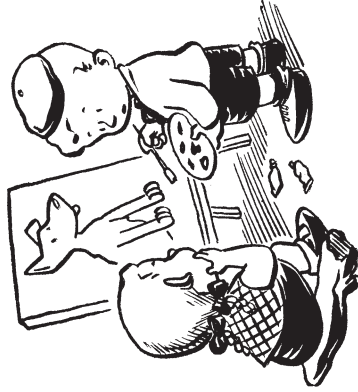

"This started out to be a Russian wolfhound, but due to the present world situation I've decided to change it to a collie."

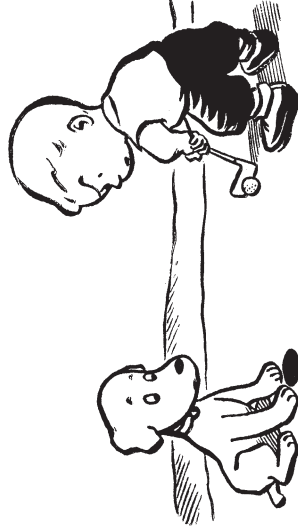

"There, that's fine . . . now don't move"

Lil' Folks

BY SPARKY

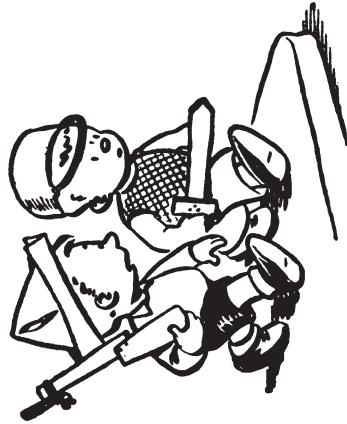

"I wonder if we could collect any terminal leave pay?"

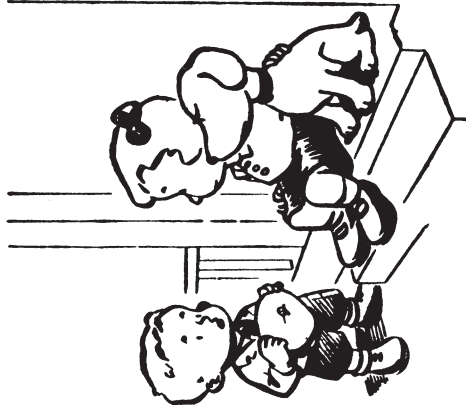

Oh, pardon me, I thought you were alone."

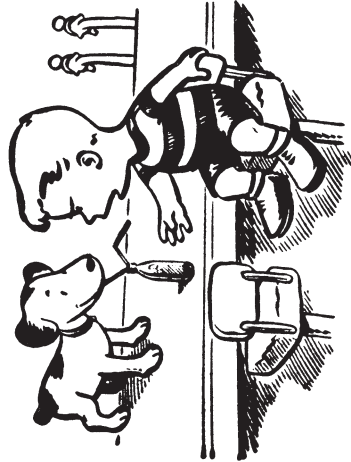

"For someone who doesn't like strawberry, you're drinking awfully fast!"

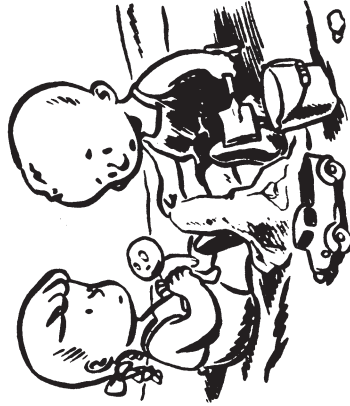

"I'd like to write short stories, and sell 'em to magazines, but I don't know how to write."

Lil' Folks

BY SPARKY

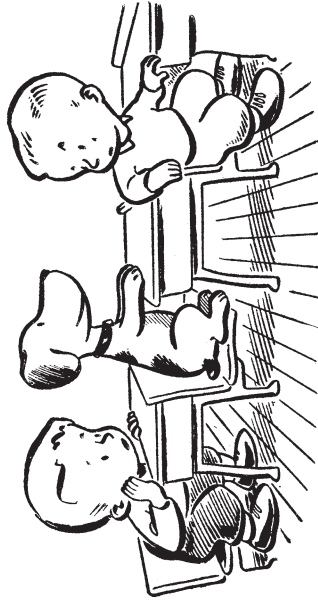

"I can hardly wait 'til she calls the roll."

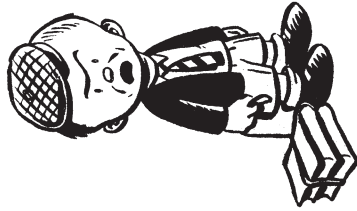

"I don't feel in the mood to say anything funny!"



"I'm positive this attitude you're taking is going to get you off to a bad start."

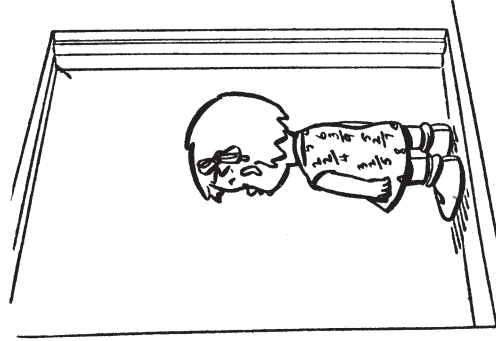

"Today we learned addition!"

Lil' Folks

BY SPARKY

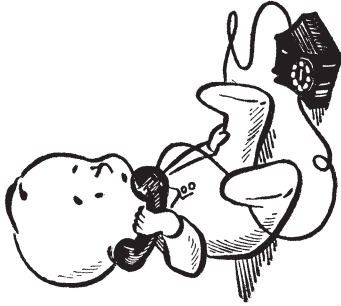

"Hello, operator? . . . Will you tell me a story?"

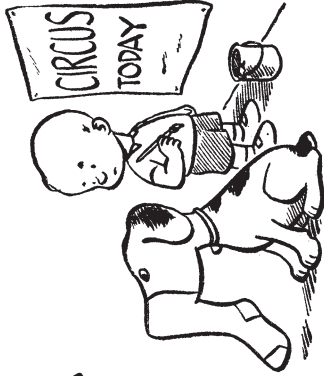

"What kind of sound does an elephant make?"



"But you can't trade me away for a tricycle! I'm your sister . . . don't you understand? Your own flesh and blood!"

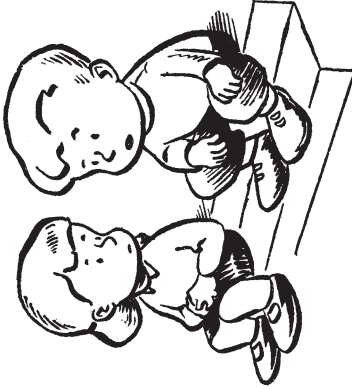
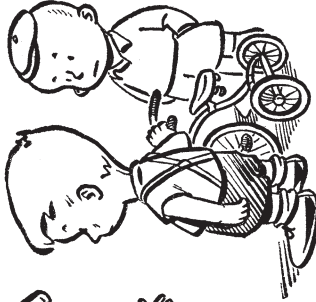

"Yes, sir, I certainly wish I were 5 again, and I knew what I know now."

Lil' Folks

BY SPARKY

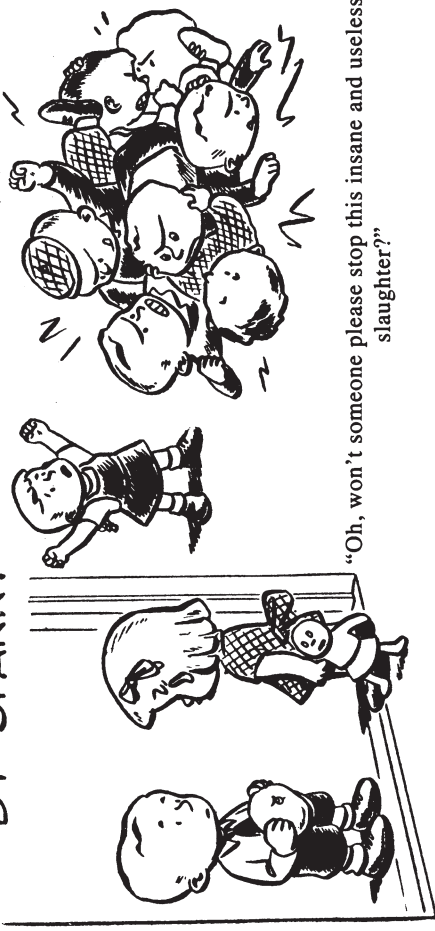

"It's not that I don't like you
... I just can't stand the sight
of you."



Lil' Folks

BY SPARKY

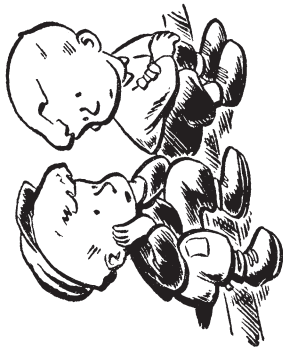

"Y'know, the girls of our generation fascinate me!"

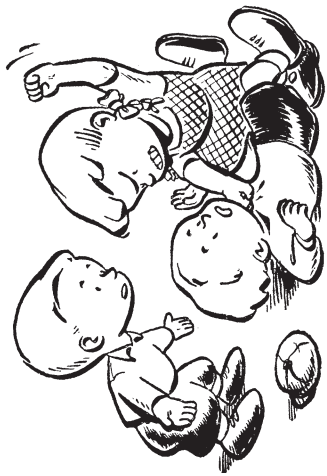

"But he's a boy, and boys are bigger than girls. They're stronger, an' got more muscles an' . . ."

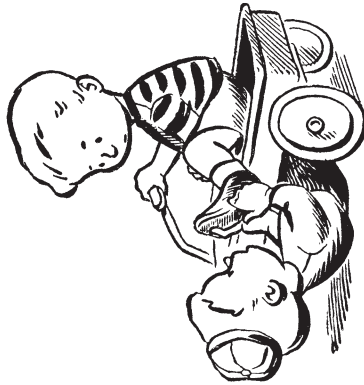

"I suggest you change to rubber soles. You'll get more mileage."

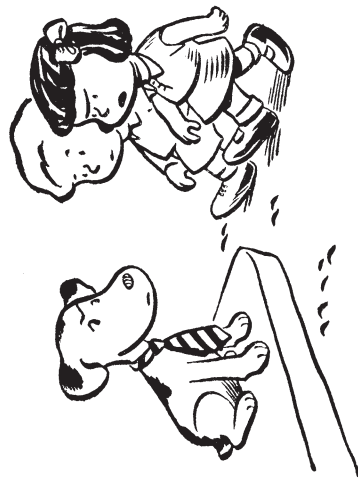

"Frankly, I think there's nothing that looks worse than a striped tie on a spotted dog."

Lil' Folks

BY SPARKY

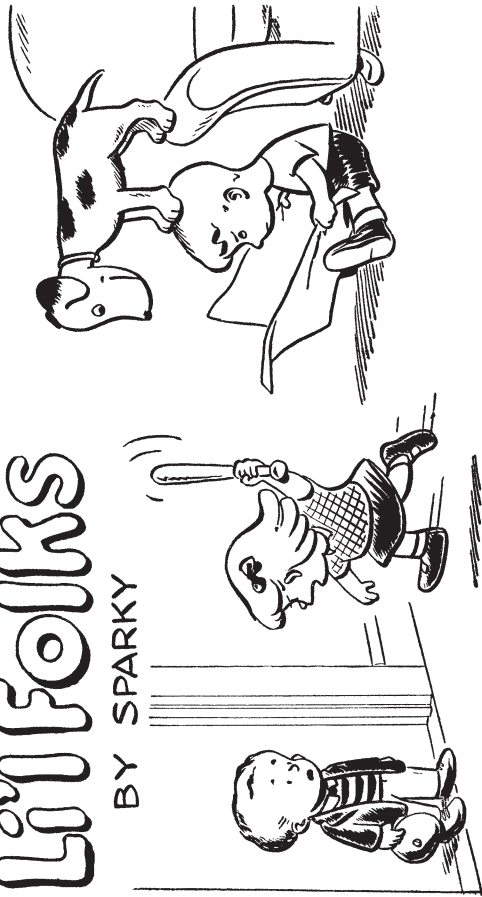

"Aren't you glad to see me?"

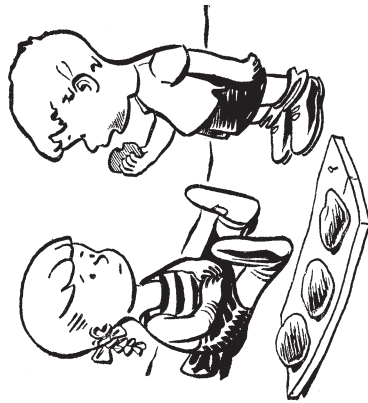

"I think I prefer Agnes' mud-pies . . .
Where she lives the earth is richer!"

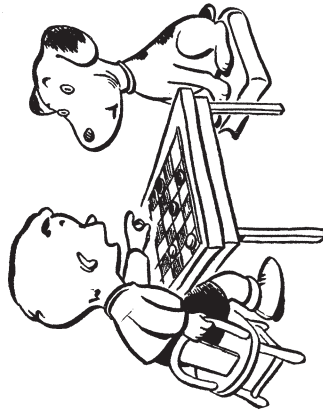

"Ha! I knew you'd think the black
ones were licorice!"

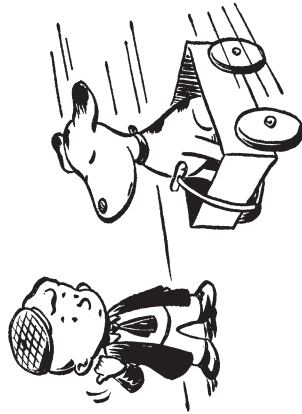

Lil' Folks

BY SPARKY

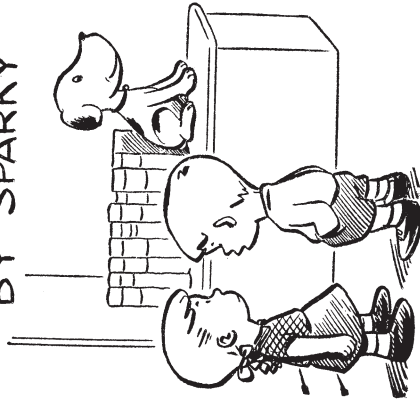

"He seems to like books so I thought I'd give him a suitable job."

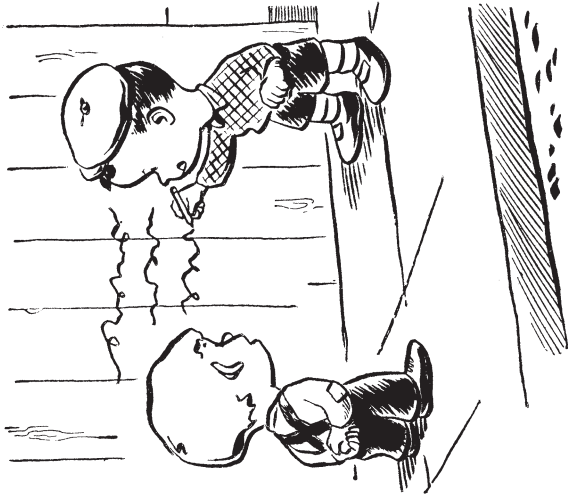

"I'm sorry I can't read . . . that certainly looks interesting!"

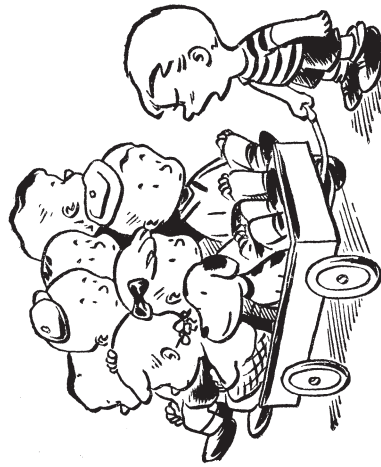

"All right, who's draggin' his feet?"

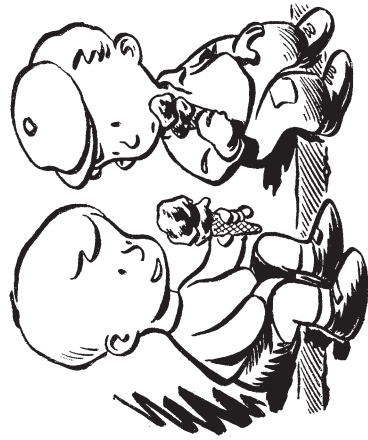

"Y' know, I think I like ice cream even better than I do girls!"

L'il Folks

BY SPARKY

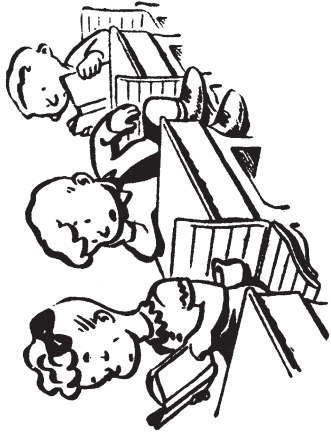
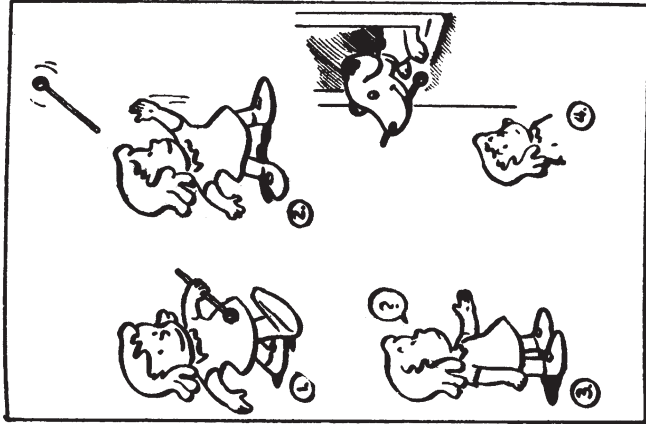

"Oh, for the good old days of pigtails and inkwells."

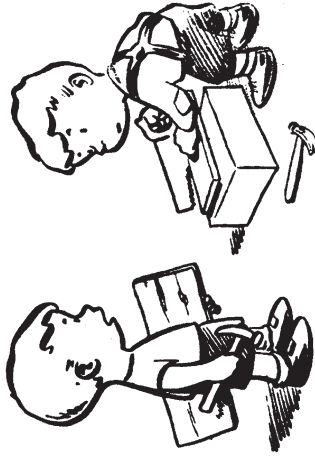

"I'd like to build myself a workbench, but I haven't got a workbench to build it on."

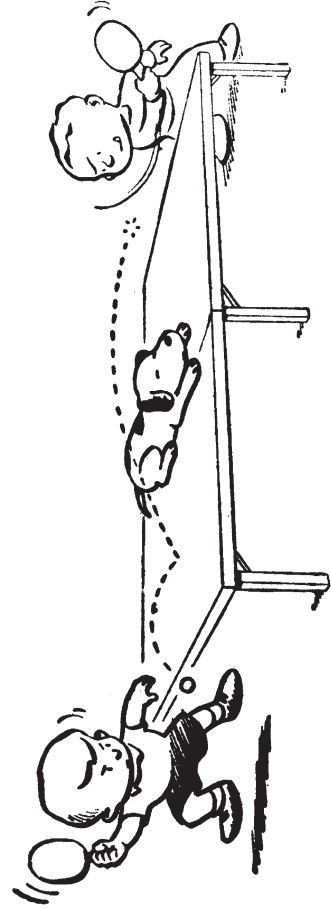

Lil' Folks

BY SPARKY

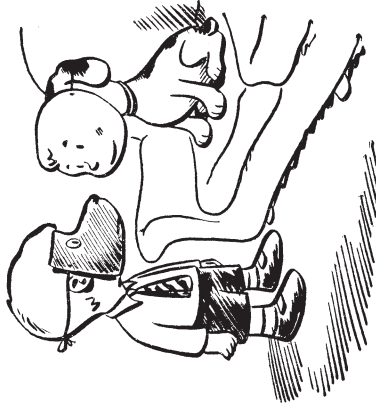

"Boo!"

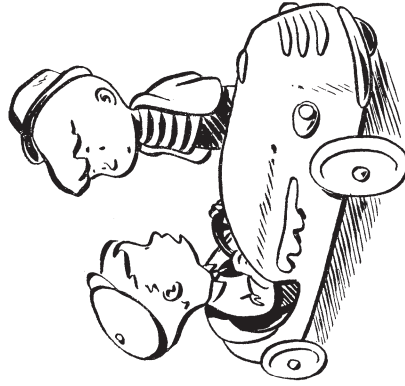

"Frankly, I thought I'd never get it. I've been on a waiting list since January!"



"This is sort of an intimate gift. I had to blow on it three times!"

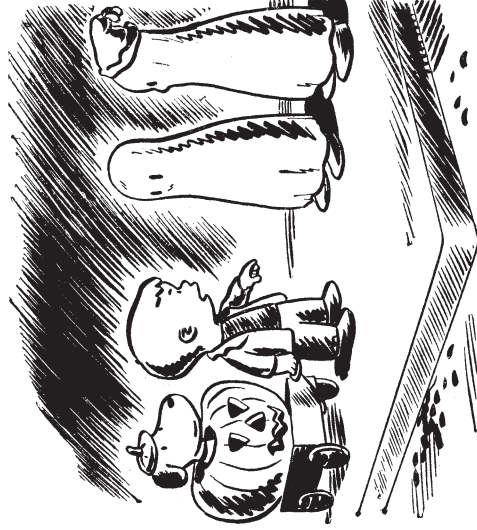

"You guys better hurry home. . . . It's Grandma's bedtime, and she says she's not going to sleep on the bare mattress!"

Lil' Folks

BY SPARKY

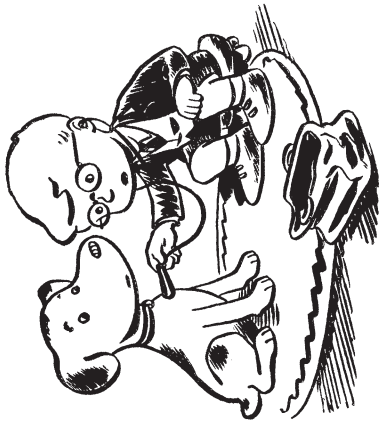

"SAY, 'WOOF!'"

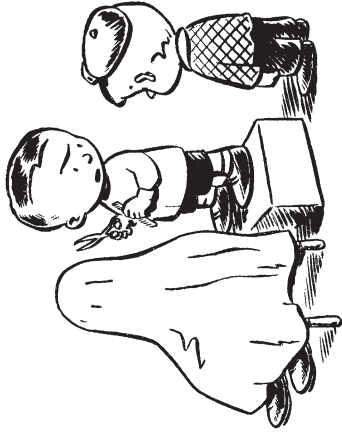

"..AND WHAT MAKES YOU THINK I'VE NEVER RUN A BARBER SHOP BEFORE?!"

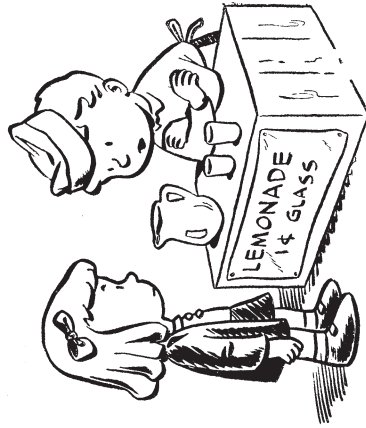

"OF COURSE I LOSE MONEY ON EACH GLASS, BUT I FIGURE I'LL MAKE MY PROFIT BY SELLING SO MANY!"

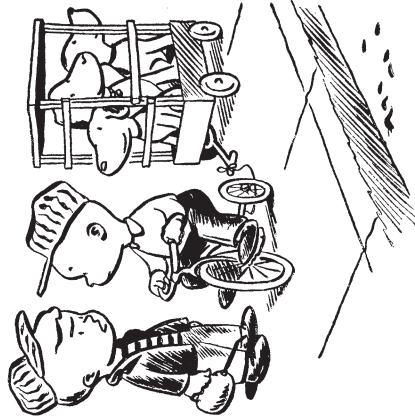

"HOW ABOUT LETTING ME BE THE ENGINEER FOR AWHILE?.. I'M TIRED OF RIDING IN THE CATTLE CAR!"

Lil' Folks

BY SPARKY

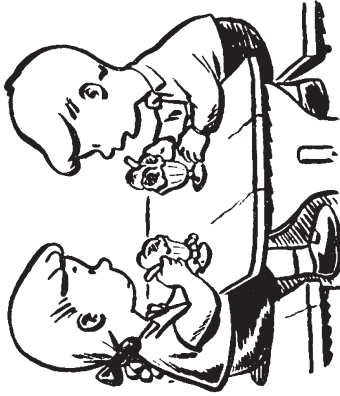

"I HOPE THIS MAKES ME DREAM TONIGHT... I GET BORED WITH JUST PLAIN SLEEPING!"

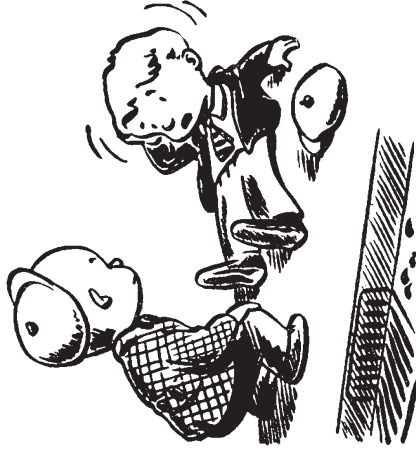

"...AND THE NEXT THING I KNEW, SHE HIT ME OVER THE HEAD WITH HER MAD-MONEY!"

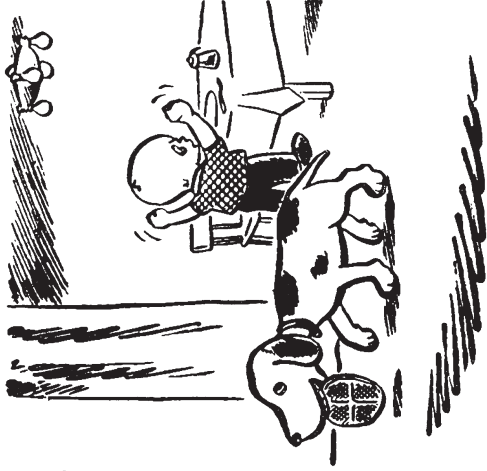

"WHO STOLE MY WAFFLE?!"

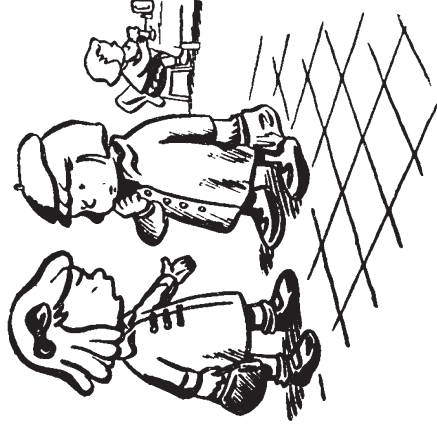

"BUT WE CAN'T SIT AT THE SAME TABLE WITH HER... WE WON'T HAVE ANYONE TO TALK ABOUT!"

Lil' Folks

BY SPARKY

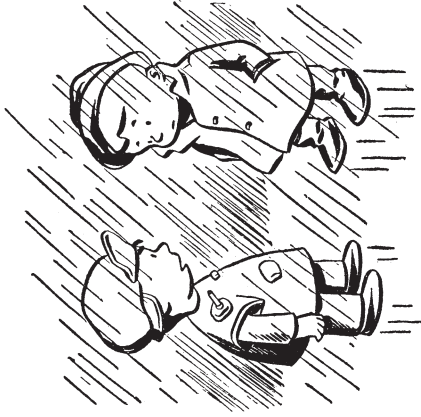

"IT'S A PRETTY GOOD RAINCOAT
EVEN THOUGH MA DID MAKE IT
OUT OF AN OLD INNER-TUBE!"

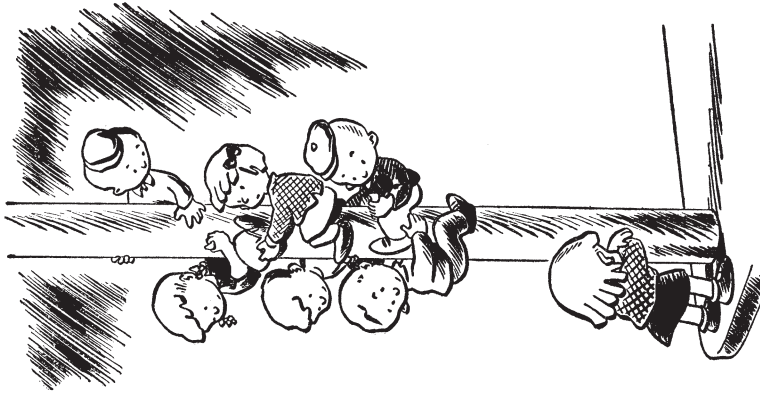

"NINETY-EIGHT...NINETY-NINE...ONE HUNDRED...
HERE I COME, READY OR NOT!"



"ALL RIGHT, I TAKE IT
BACK... YOUR GIRL FRIEND
HASN'T GOT LONG EARS!"

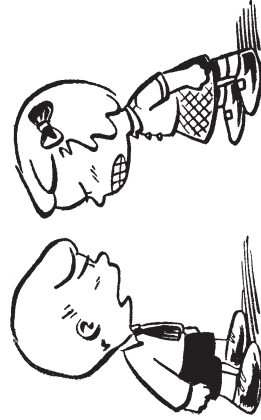

"YOU...YOU... YOU GIRL, YOU!!"

Lil' Folks

BY SPARKY

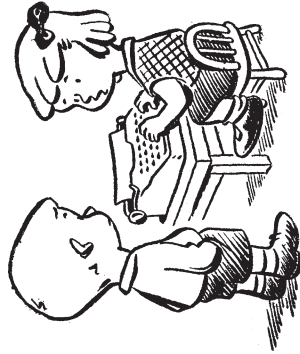

"I CAN TYPE TWO HUNDRED LETTERS A MINUTE, BUT I CAN'T MAKE 'EM INTO WORDS!"

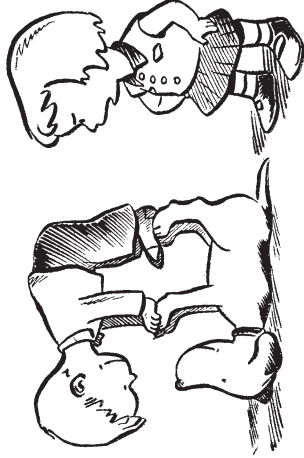

"..AND JUST WHAT DO YOU INTEND TO DO IF RINGLING BROTHERS TURNS YOU DOWN?!"

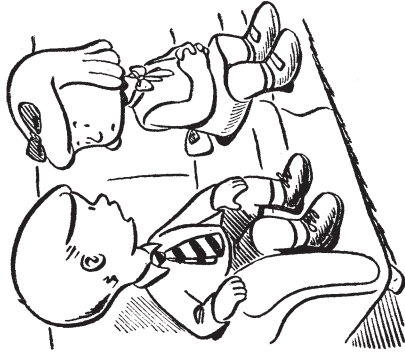

"I'M PROBABLY THE ONLY FELLOW YOU'LL EVER KNOW WHO CAN WHISTLE THE ENTIRE SCORE OF 'DIE FLEPERMAUS'!"

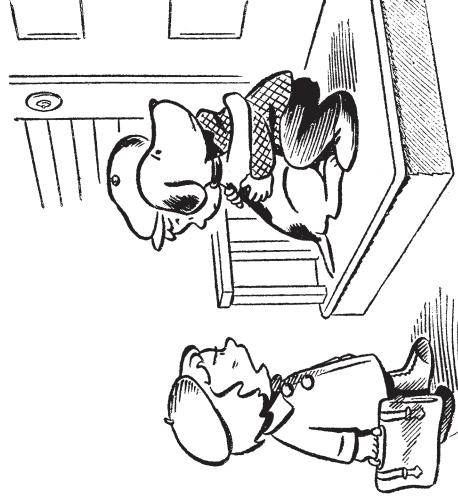

"I WISH YOU TWO WOULD STOP THESE SAD FAREWELLS....AFTER ALL, SCHOOL LASTS ONLY A FEW HOURS!"

Lil'Folks

BY SPARKY

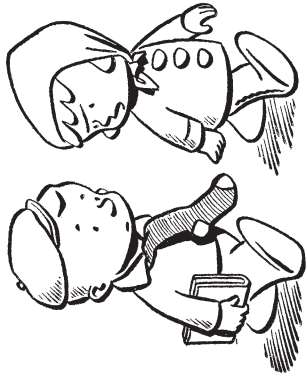

" I WOULD SUGGEST THAT YOU STOP TRYING TO DRESS IN THE DARK! "

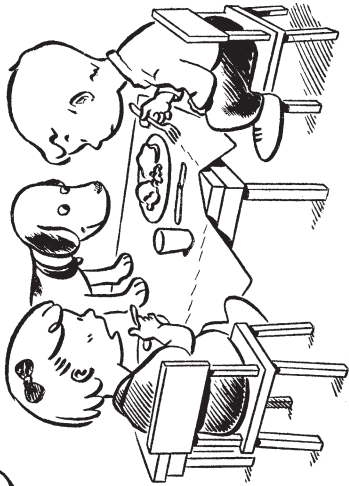

" I THINK HE'S BEING VERY IMPOLITE SO JUST IGNORE HIM! "

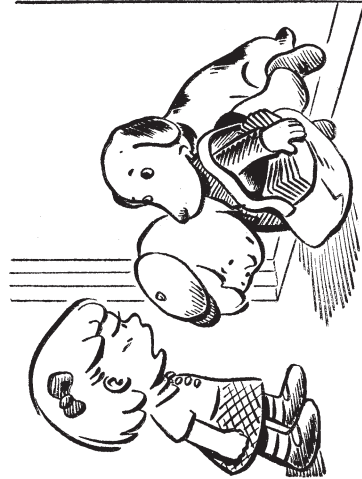

" HOW MANY TIMES DO I HAVE TO TELL YOU ?! JUST THE PAPER.... NOT THE WHOLE PAPERBOY !! "

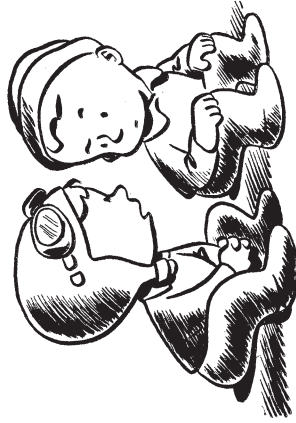

" NO, I DISAGREE WITH YOU... GIRLS ARE MORE THAN JUST A NECESSARY EVIL.. "

Lil' Folks

BY SPARKY

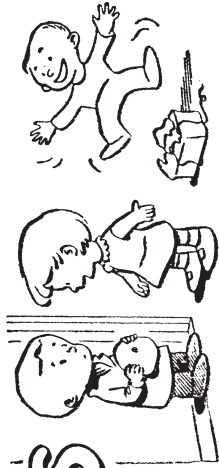

"COME ON IN... WE'RE PRACTISING OPENING CHRISTMAS PRESENTS!"

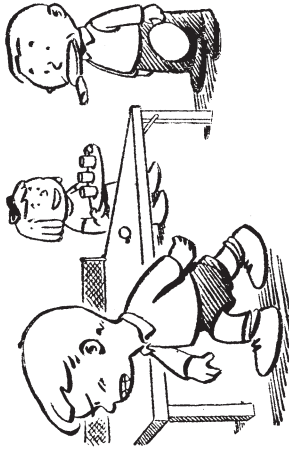

"WELL, WHO WON THE GAME?"

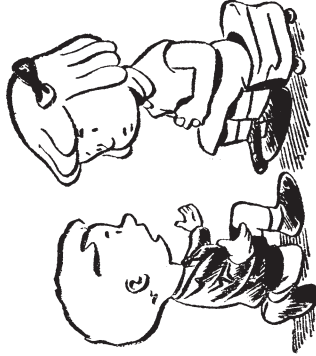

"..BUT I TELL YOU IT'S THE FUTURE THAT COUNTS...I DON'T CARE ANYTHING ABOUT YOUR PAST!"

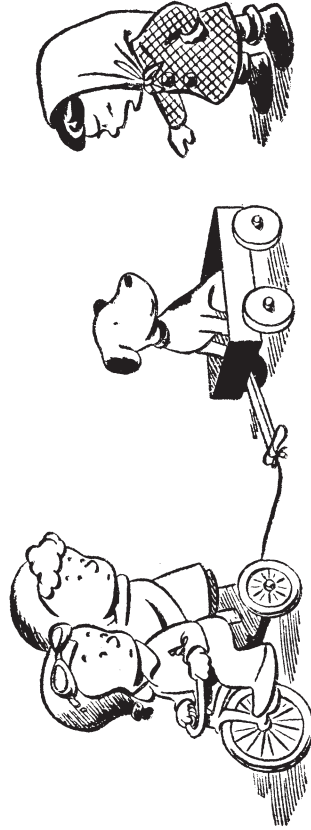

"WHAT KIND OF A BLIND DATE DO YOU CALL THIS?!"

Lil' Folks

BY SPARKY

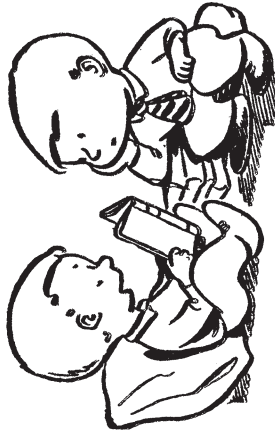

"HOW SHARPER THAN A SERPENT'S TOOTH IT IS TO HAVE A THANKLESS CHILD'... I THINK THAT MEANS YOU!"

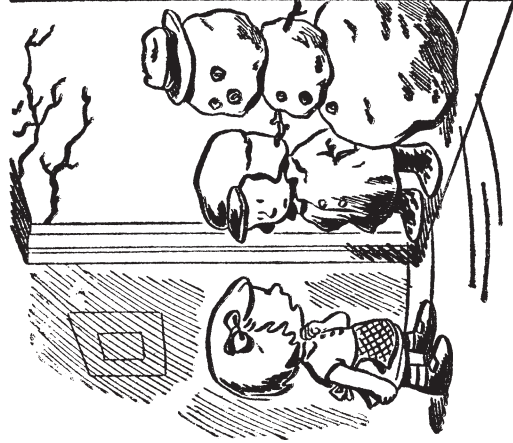

"MOM SAYS YOU CAN COME IN, BUT YOUR FRIEND WILL HAVE TO STAY OUTSIDE."

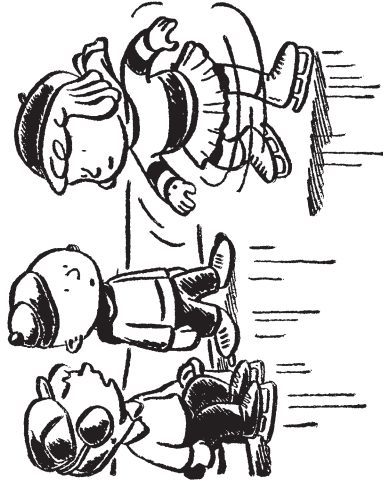

"IF YOU WANTED TO MEET HER I COULD INTRODUCE YOU, IF I KNEW WHO SHE WAS !"

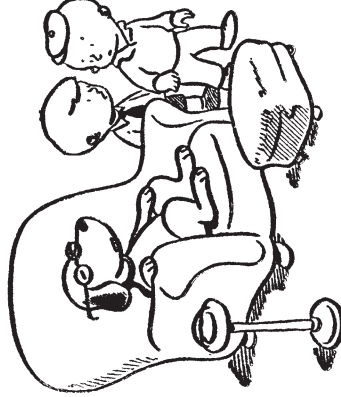

"IT'S SOMETHING ABOUT HIS BEING THIS MONTH'S DOG OF DISTINCTION!"

Lil' Folks

BY SPARKY



" I DON'T THINK HE HAS MUCH CONFIDENCE IN ME ! "

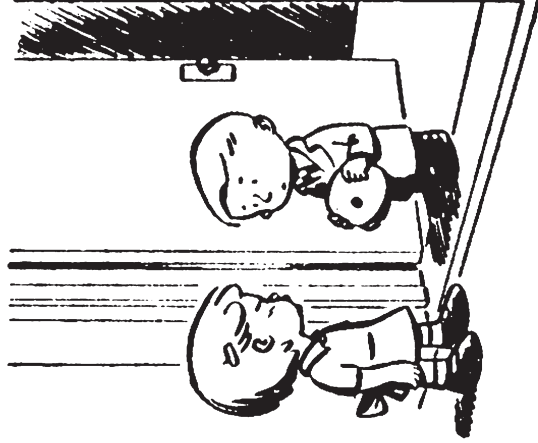

" OH, RATS! I THOUGHT IT WAS SOMEBODY IMPORTANT ! "

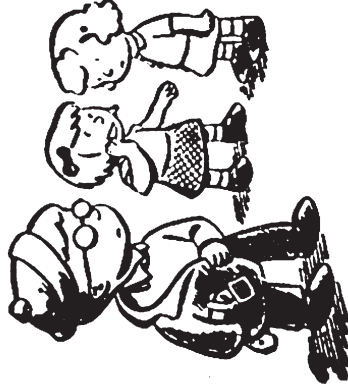

" QUICK ! INTRODUCE ME BEFORE HIS GLASSES UNFOG ! "

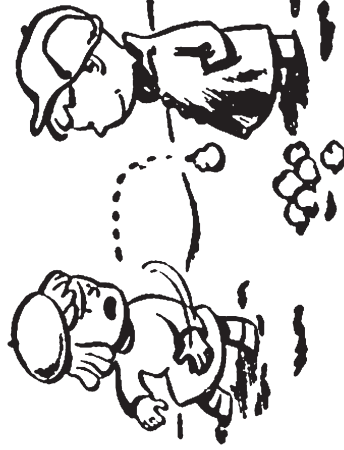

" YOU WOULDN'T ACT SO SMUG IF I COULD THROW FARTHER ! "

Lil' Folks

BY SPARKY

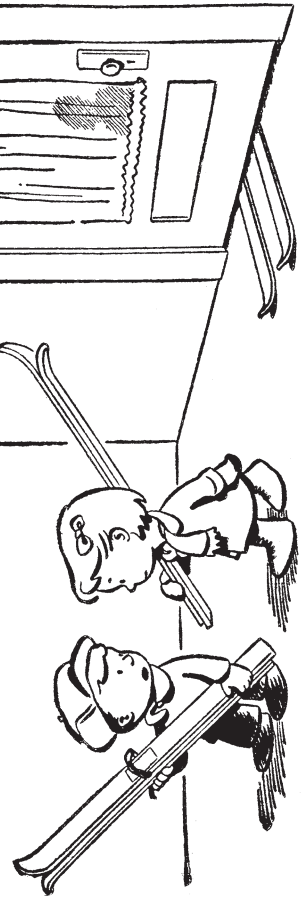

" WHAT HAPPENED TO EDDIE?...DIDN'T HE COME IN ? "

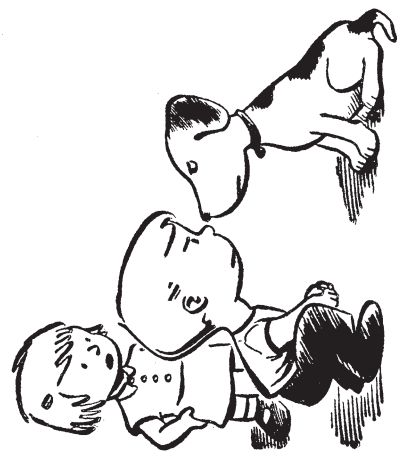

" THIS IS CERTAINLY GOING TO RUIN THE OLD 'MAN OVER BEAST' THEORY ! "

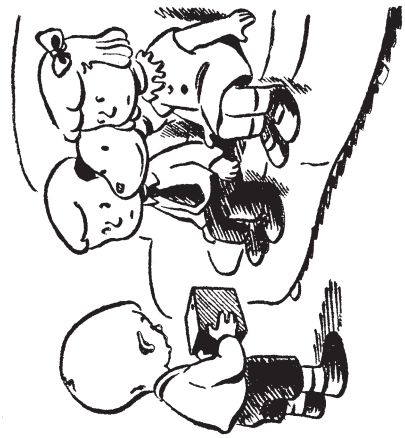

" HOW COME I SEE THREE FACES BUT ONLY FOUR LEGS ? "

Lil' Folks

BY SPARKY

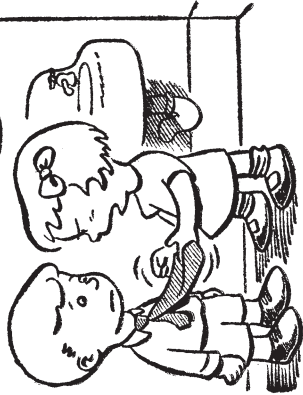

"OH, STOP COMPLAINING!
IF THERE'S NO TOWEL,
THERE'S NO TOWEL."

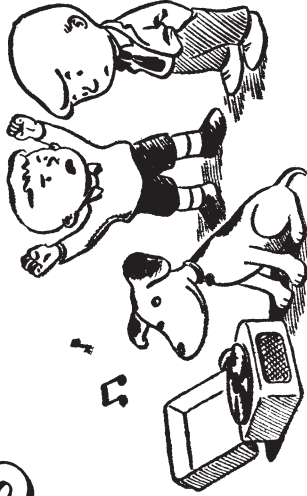

"THE WHISTLER AND HIS DOG!....
OVER AND OVER, DAY AFTER DAY....
IT'S DRIVING ME CRAZY!"

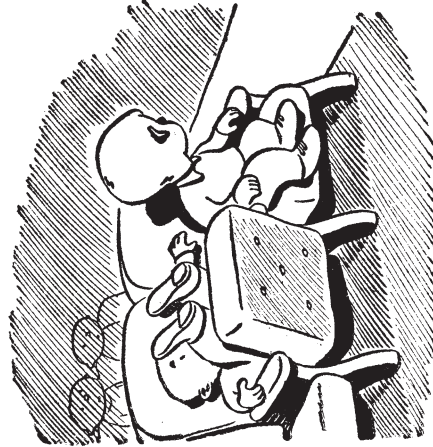

"BOY, I'VE NEVER SEEN
ANYONE LEAVE IN SUCH
A HURRY!"

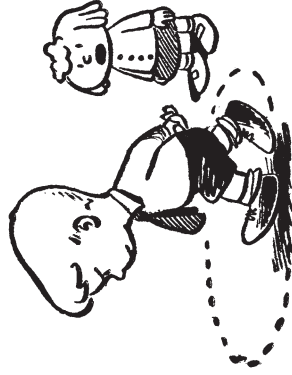

"IF YOU ASK ME, I SAY
STOP WORRYING ABOUT THE
YOUNGER GENERATION, AND
LET 'EM TAKE CARE OF
THEMSELVES!"

Lil' Folks

BY SPARKY

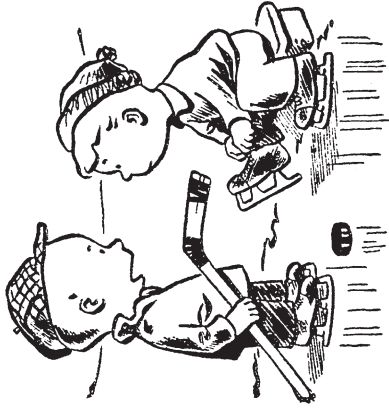

"THE GAME'S OFF....
GRANDMA BROKE HER
GOALIE STICK!"

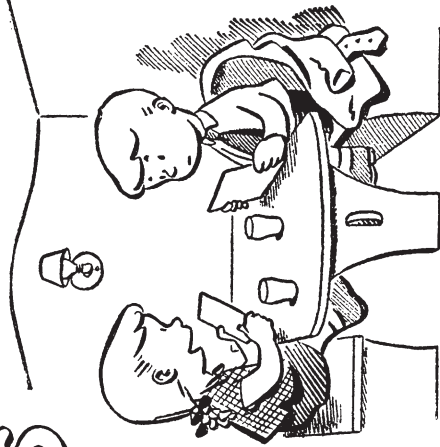

"HERE'S YOUR BIG CHANCE
TO IMPRESS ME!"

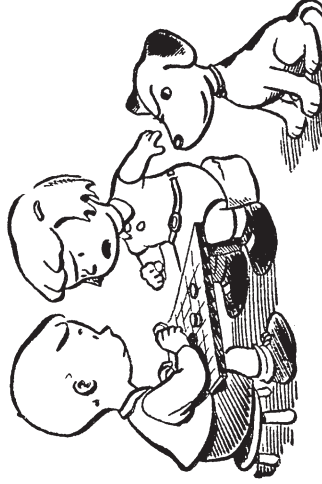

"CAN'T YOU MAKE HIM STOP
WINKING AT ME?!"

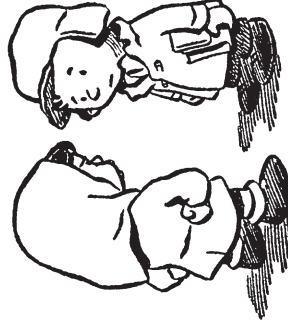

"YOU GO RIGHT IN
THERE, AND TELL YOUR
TEACHER SHE CAN'T TALK
THAT WAY ABOUT MY
FUTURE HUSBAND!"

Lil' Folks

BY SPARKY

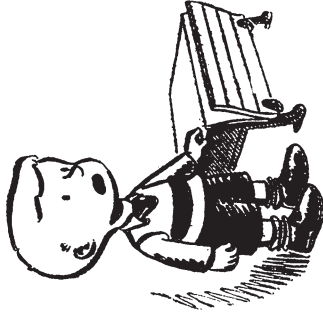

"THE WAY I SEE IT IS... IF AT FIRST YOU DON'T SUCCEED... QUIT!"

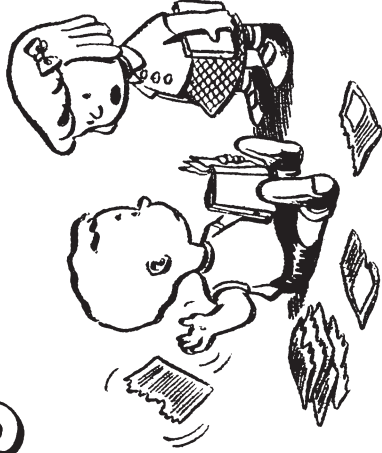

"I CAN SEE THAT YOU'RE GOING TO HAVE TO LEARN TO USE A BOOK-MARK!"

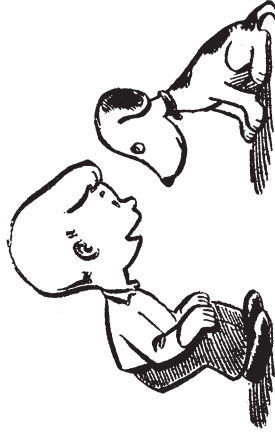

"A PENNY FOR YOUR THOUGHTS..."

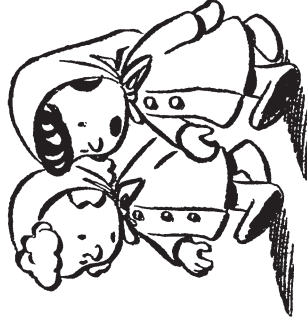

"I'M AFRAID THAT LEAP-YEAR WILL BE OVER BY THE TIME I GROW UP."

Lil'Folks

BY SPARKY

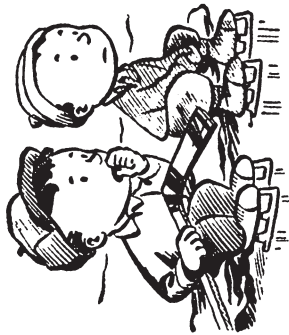

"OH, OH,... IT LOOKS BAD FOR OUR SIDE... GRANDMA JUST GOT A FIVE-MINUTE PENALTY!"

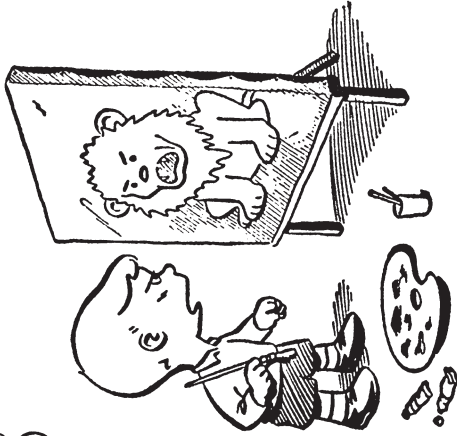

" GRR... RRR... ROWF....GRR.. "

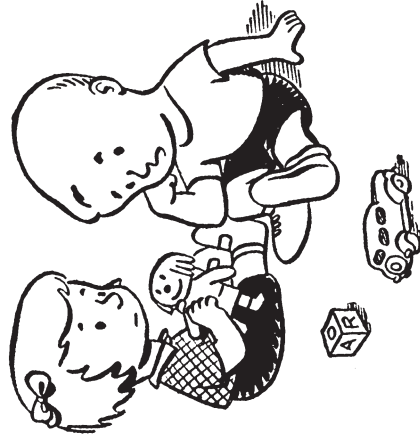

" I CERTAINLY DO DREAD THE COMING OF MY SECOND CHILDHOOD! "

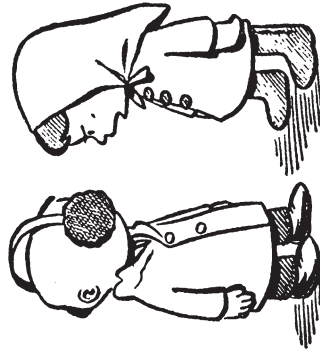

" WHAT DO YOU MEAN.. YOUR EARS ARE STILL COLD ?! "

Lil' Folks

BY SPARKY

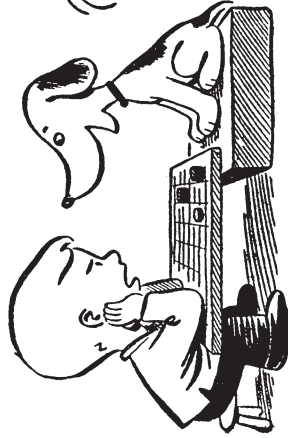

"DON'T LOOK SO HAPPY...
YOU HAVEN'T WON YET!"

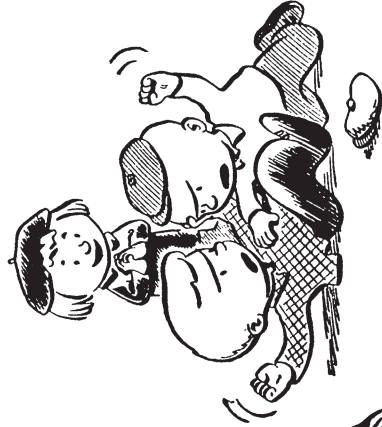

"DON'T FIGHT OVER ME,
BOYS....I'M NOT WORTH IT...
UNLESS, OF COURSE, YOU
REALLY WANT TO!"

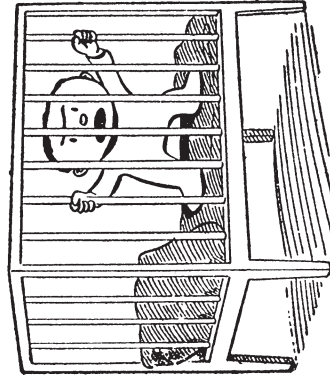

"LEMME OUT OF HERE!
I'M INNOCENT, I TELL
YA!....I DEMAND TO
SEE THE WARDEN!!"

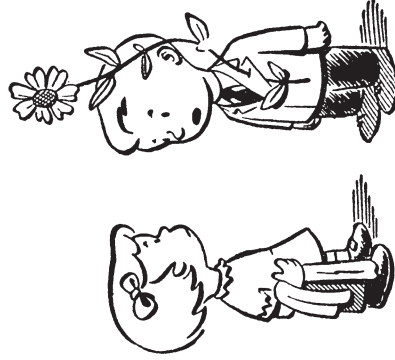

"WHAT'S THE MATTER?
IS IT THE WRONG
COLOR?"

Lil' Folks

BY SPARKY



"I REALLY BELIEVE SHE'S THE STRICTEST TEACHER WE'VE EVER HAD!"

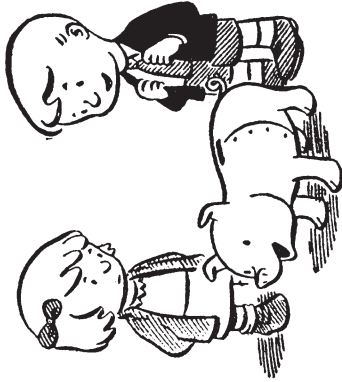

"IT'S MY OWN INVENTION... A NEW PIGGY BANK DESIGNED TO HOLD TEN THOUSAND DOLLARS!"

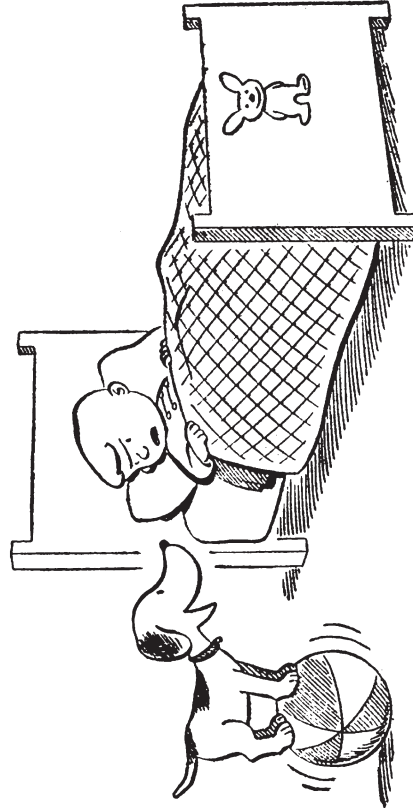

"ALL RIGHT, ALL RIGHT,...LET'S BREAK IT UP, AND GO TO BED!"

Lil' Folks

BY SPARKY



"THROUGH NO FAULT OF
MY OWN I WILL NOW PLAY
A CELLO SOLO ON THE
VIOLIN..."

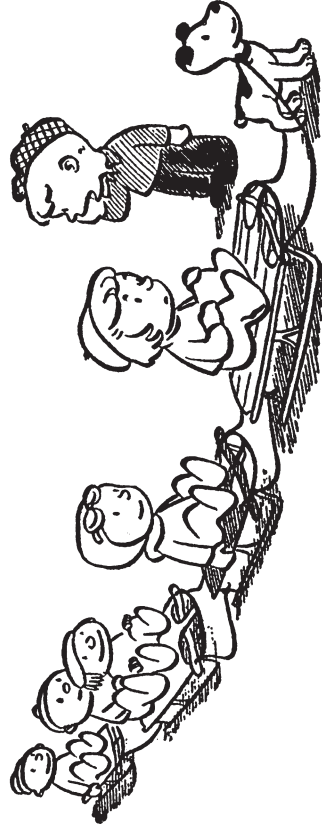
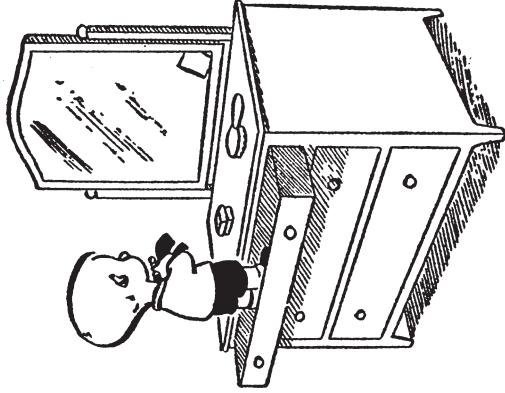

"ALL RIGHT,.. IS EVERYBODY READY NOW? HANG ON
TIGHT! WE DON'T WANT ANYONE HURT, YOU KNOW!"

Lil' Folks

BY SPARKY

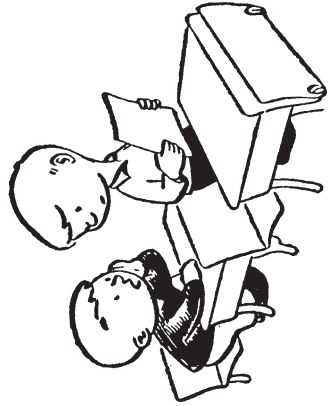

"I DIDN'T GET MY HOMEWORK DONE....SEE IF YOU CAN START A FILIBUSTER!"

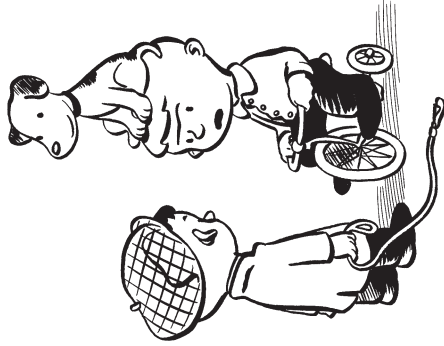

"DOG?... WHY, NO....
WHAT MAKES YOU THINK
I'VE SEEN YOUR DOG?"

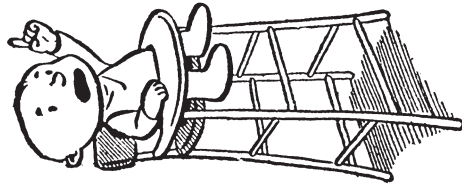

"GARÇON!"

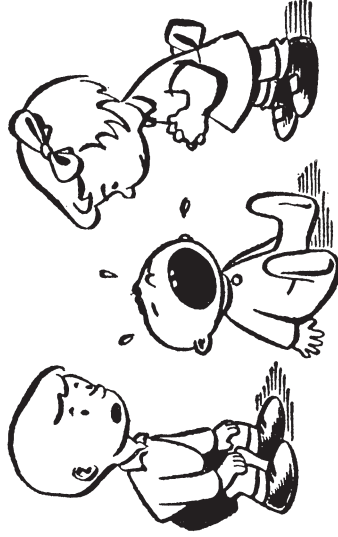

"DIDN'T ANY DIRECTIONS
COME WITH HIM?"

Lil' Folks

BY SPARKY

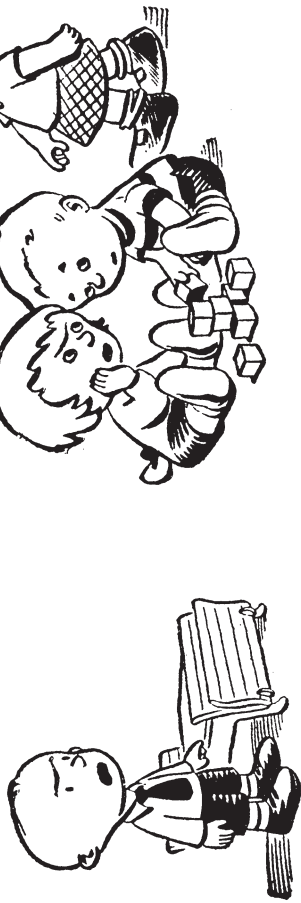

"FURTHERMORE, I REFUSE
TO ANSWER ANY QUESTIONS
UNTIL I'VE SEEN MY LAWYER!"

"WHO'S THAT OLD HAG?"

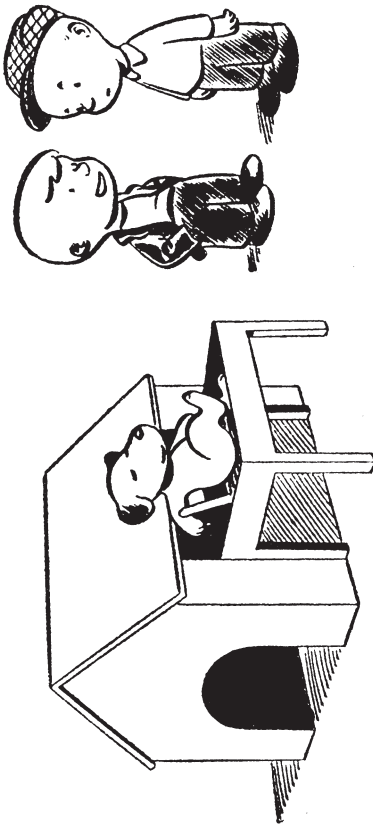

"ALL HIS LIFE HE'S WANTED A SUNPORCH!"

Lil' Folks

BY SPARKY

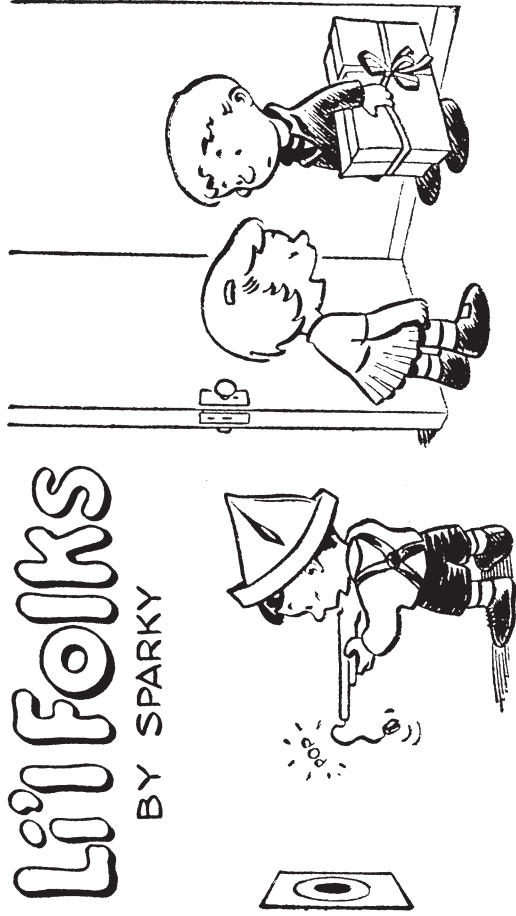

"HMM...MISSED AGAIN!"

"MY BIRTHDAY WAS
YESTERDAY, BUT BY ALL
MEANS COME IN!"



"LADIES AND GENTLEMEN, YOUR ATTENTION PLEASE!...
I HAVE HERE A MESSAGE FROM THE UNITED NATIONS!!"

Lil' Folks

BY SPARKY

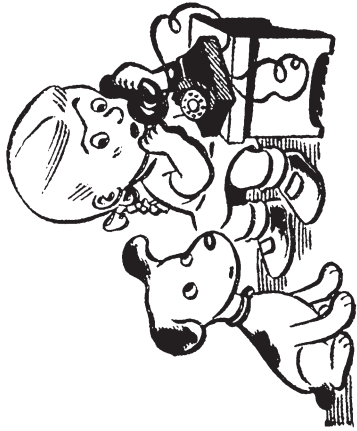

"I'LL HAVE TO TELL YOU LATER...
I CAN'T TALK NOW!"

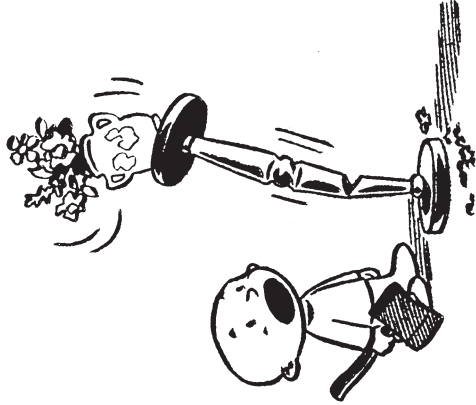

"TIMBER!!!"

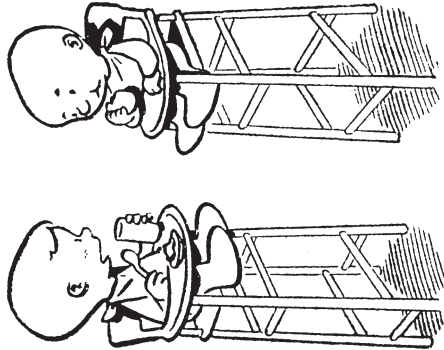

"I FIND THAT THIS HIGH
ALTITUDE DOES WONDERS
FOR MY APPETITE."

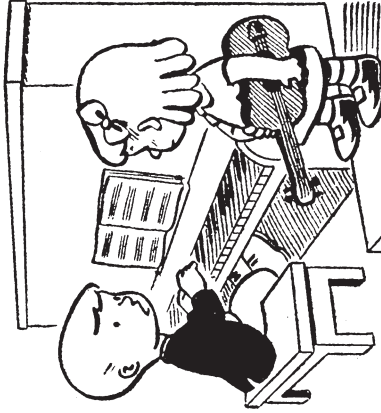

"I'VE HAD THE AWFUL FEELING
LATELY THAT BEETHOVEN
IS GOING TO KILL ME!"

Lil' Folks

BY SPARKY

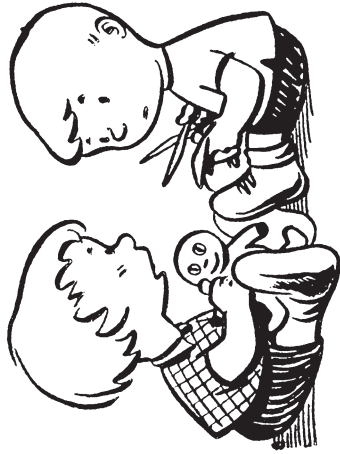

"DO YOU HAVE TO GET MARRIED TO BE A MOTHER-IN-LAW?"

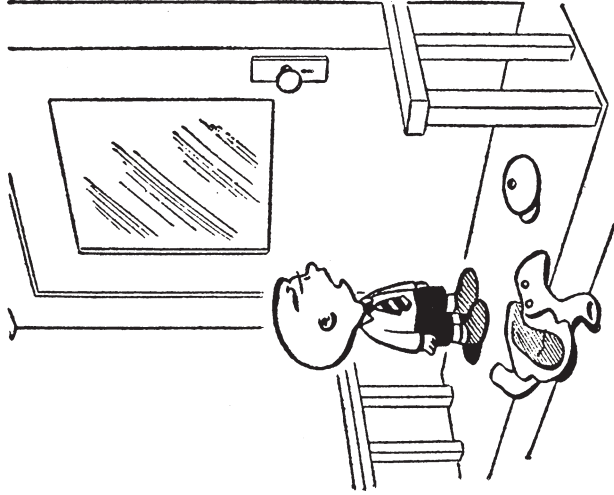

"NOW LOOK WHAT YOU'VE DONE... YOU'VE HURT MY FEELINGS!"

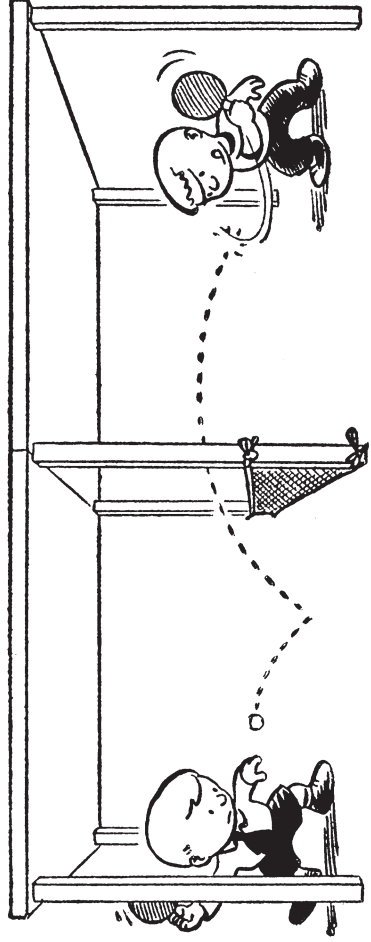

Lil' Folks

BY SPARKY

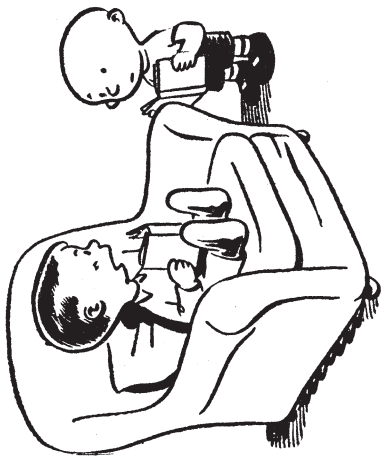

"ASK ME AGAIN SIX WEEKS FROM NOW... I'LL BE OLDER AND WISER THEN "

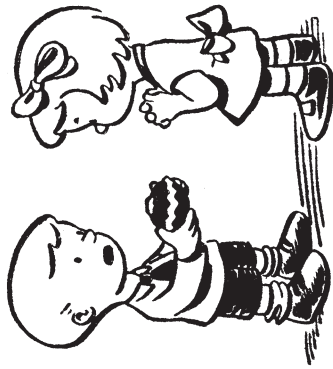

"HAPPY EASTER, AND DON'T EAT IT TOO FAST IT COST ME FIFTY CENTS!"

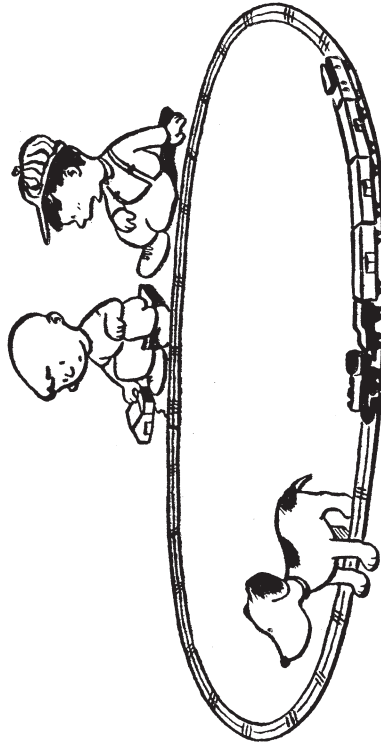

"KEEP YOUR EYE ON THE TUNNEL. I THINK IT'S GOING TO MOVE!"

Lil' Folks

BY SPARKY

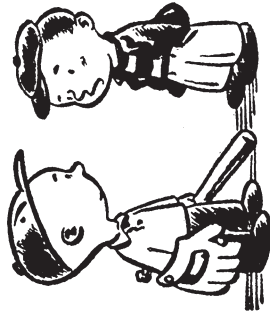

"BAD NEWS....GRANDMA'S MAD, AND WON'T LET US BORROW HER CATCHER'S MASK!"

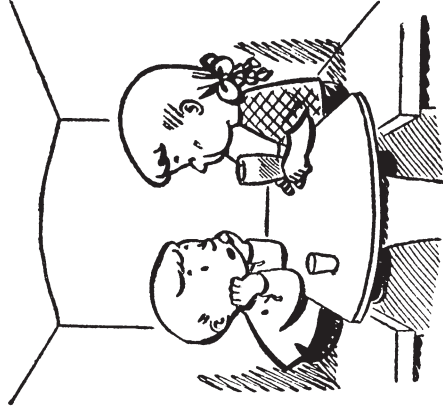

"ARE YOU STILL THE SAME PATRICIA SMITH THAT I USED TO KNOW SO WELL?"

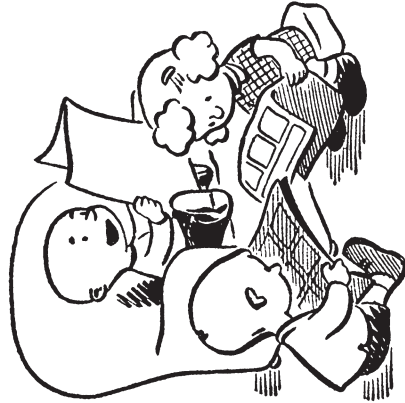

"I ALWAYS ENJOY READING 'LIL' FOLKS...IT GIVES ME A FEELING OF SUPERIORITY!"

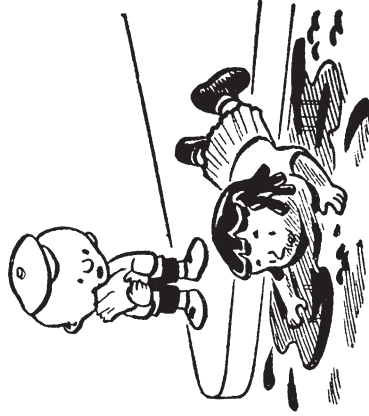

"BOY, WASN'T IT LUCKY I WAS CARRYING THE ICE CREAM?"

Lil' Folks

BY SPARKY

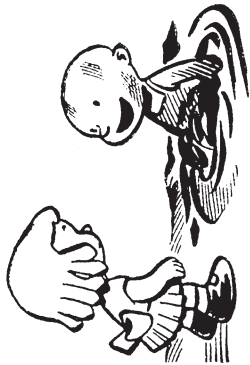

" YOU KNOW THE OLD SAYING, 'A LITTLE DIRT NEVER HURT ANYBODY!'"

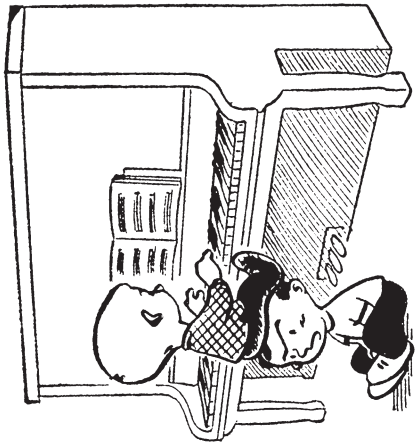

" YOU CAN'T IMAGINE HOW GLAD I'LL BE WHEN YOU GET THAT NEW PIANO STOOL!"

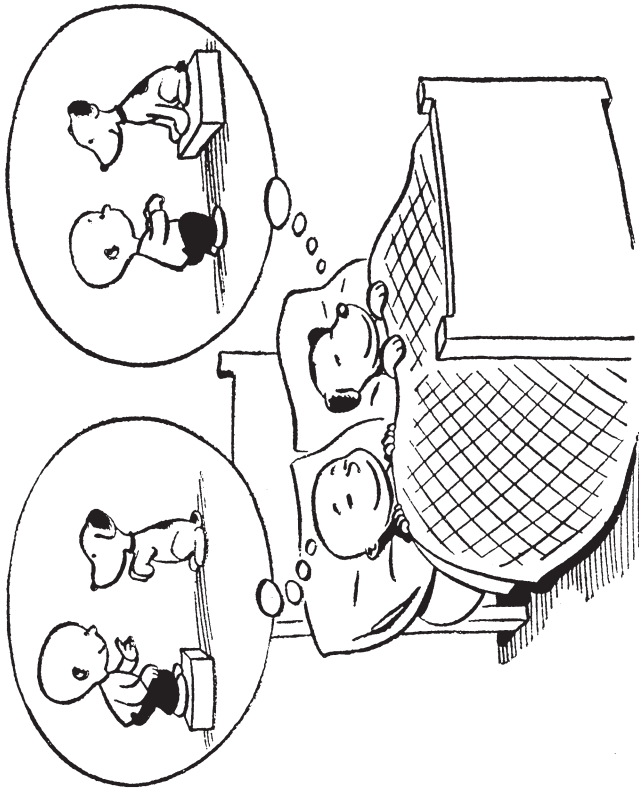

Lil' Folks

BY SPARKY

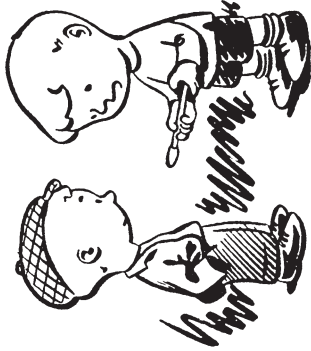
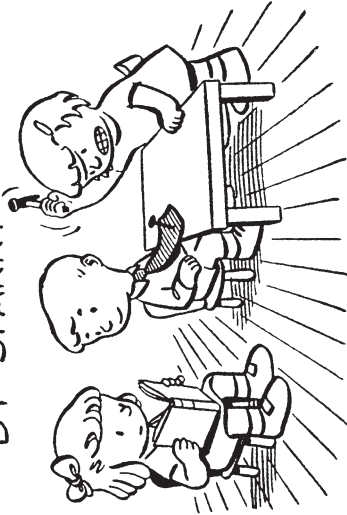

"BOY, THIS IS A
SWELL BEANSHOOTER.
DO YOU KNOW WHAT
CALIBER IT IS?"

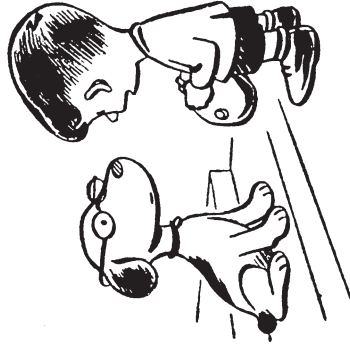

"YOU LOOK LIKE AN
INTELLIGENT FELLOW...
MAYBE YOU CAN GIVE
ME THE ADVICE I'M
SEEKING..."

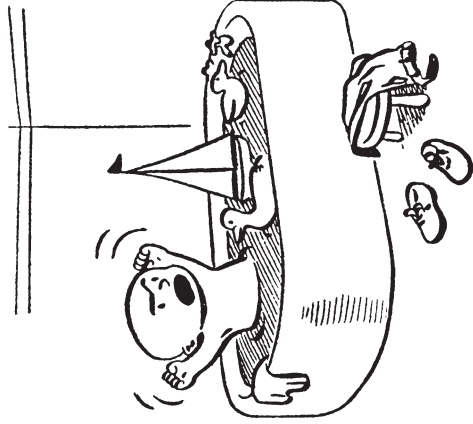

"DUCKS, BOATS, SWANS...
GREAT SCOTT! CAN'T A MAN
EVER HAVE ANY PRIVACY?!"

Lil' Folks

BY SPARKY

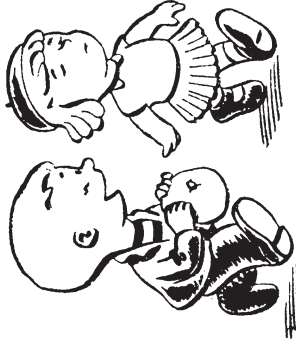

"HAVEN'T WE MET
SOMEWHERE BEFORE? PARIS,
VIENNA,...OR WAS IT THE
CORNER DRUGSTORE?"

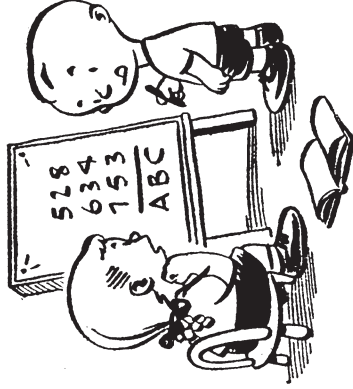

"WHAT GRADE DID
YOU SAY YOU WERE IN?"

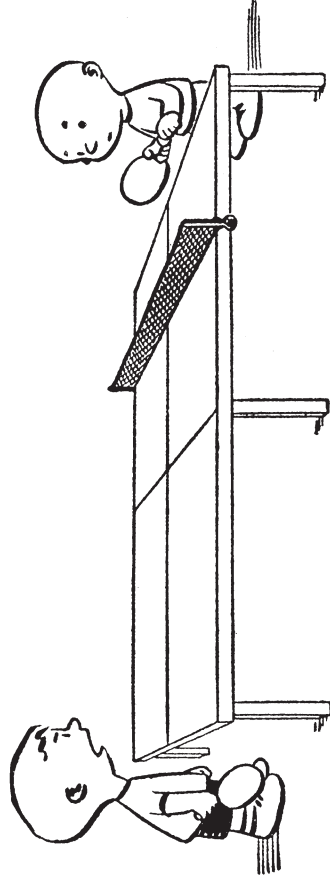

"BEFORE WE START THIS NEXT GAME, LET'S
HAVE ANOTHER LOOK AT THE RULE BOOK!"

Lil' Folks

BY SPARKY

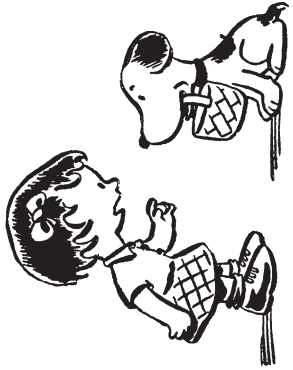

"AND IF YOU GET LOST, JUST STOP, AND ASK A POLICE DOG."

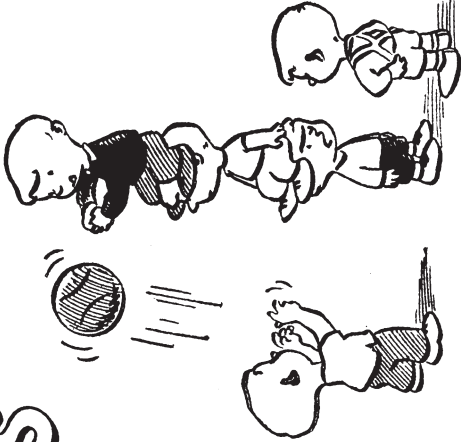

"THERE'S NO DOUBT ABOUT IT... WE'RE GOING TO HAVE TO CHIP IN, AND BUY SOME LUMBER!"

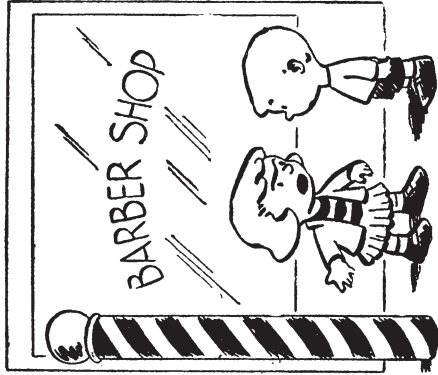

"ALL RIGHT THEN, PUT IT THIS WAY... DOES PEPPERMINT HAVE SLIVERS?"

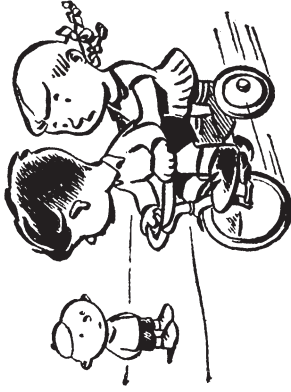

"WHAT DO I CARE IF SHE FALLS OFF? WE'RE NOT GOING STEADY!"

Lil' Folks

BY SPARKY

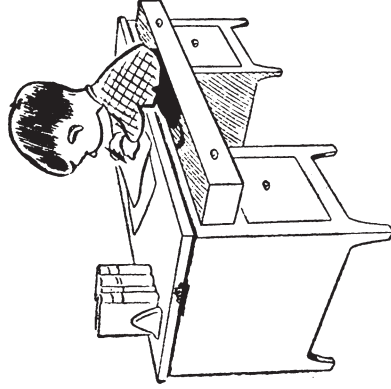
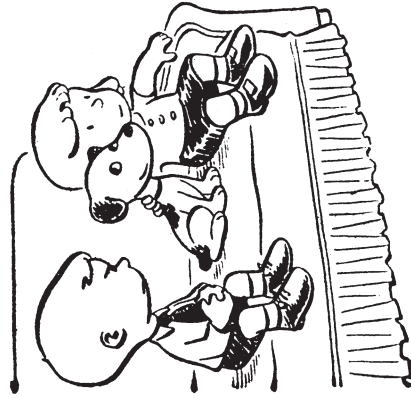
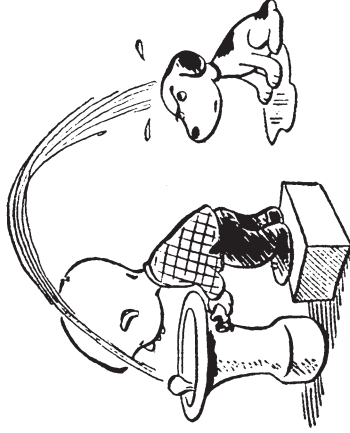
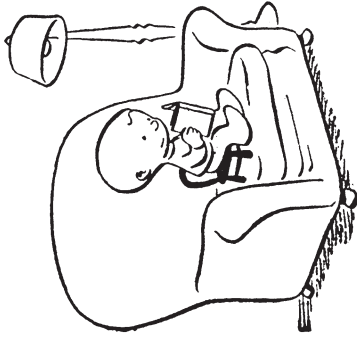

... AND A "HAPPY MOTHER'S
DAY" TO ALL MOTHERS OF
"LIL FOLKS!"

Lil' Folks

BY SPARKY



"HI!"

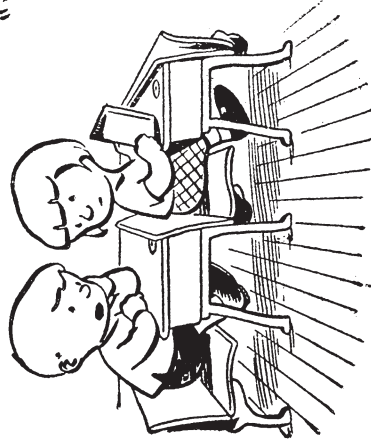

"IT GOES WITHOUT SAYING THAT MY WERE PRESENCE HERE INDICATES I MUST BE OUT OF MY MIND!"

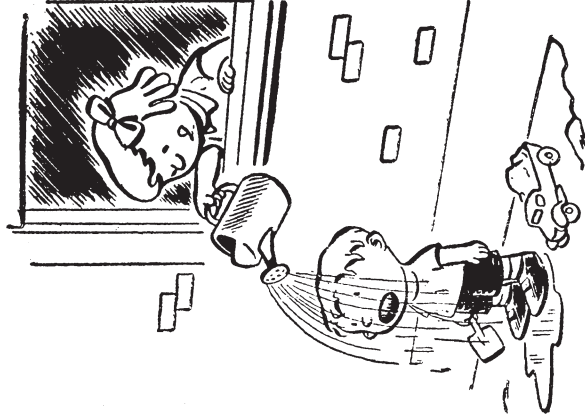

"...RAIN, RAIN, GO AWAY...COME AGAIN SOME OTHER DAY!"

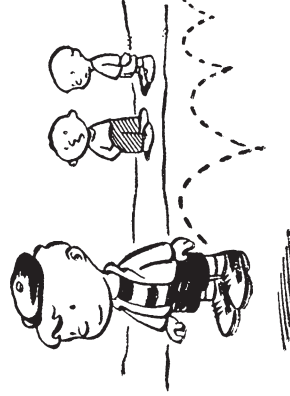

"I'VE ALWAYS ADMIRER HIM... HE'S SO CAREFREE.."

Lil' Folks

BY SPARKY

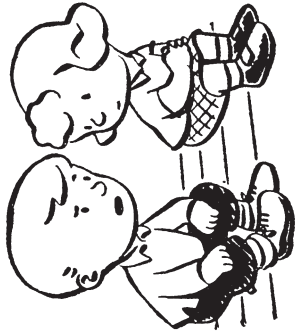

" THEN AGAIN, SOMETIMES
I THINK GROWNUPS AREN'T
EVEN HUMAN ! "

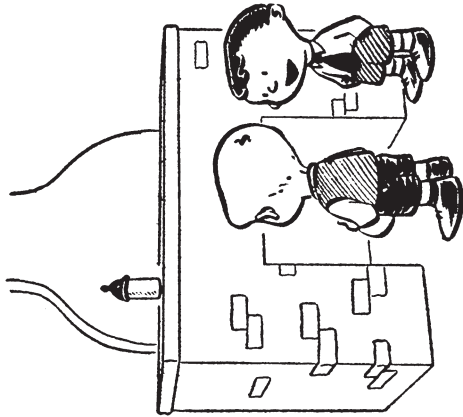

" I JUST KEEP IT AS
A REMINDER...I REALLY
HAVEN'T HAD A DRINK
IN YEARS ! "

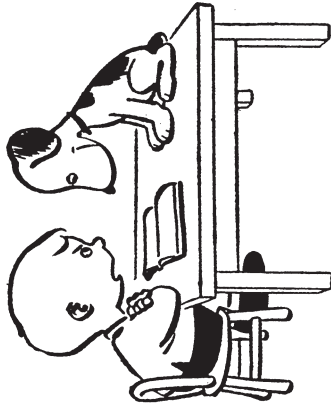

" STOP SMILING! THIS
IS A VERY SAD
STORY! "

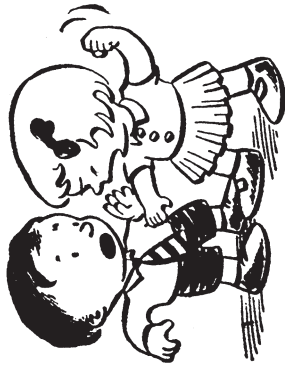

" DON'T HIT ME! JUST
SAY SOMETHING SARCASTIC! "

L'il Folks

BY SPARKY

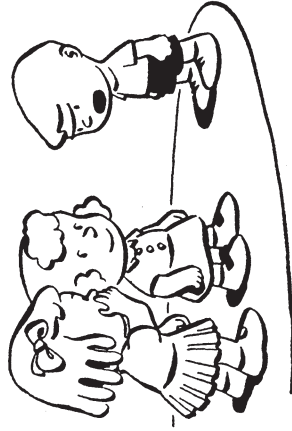

"MEOW,...MEOW,...MEOW!"

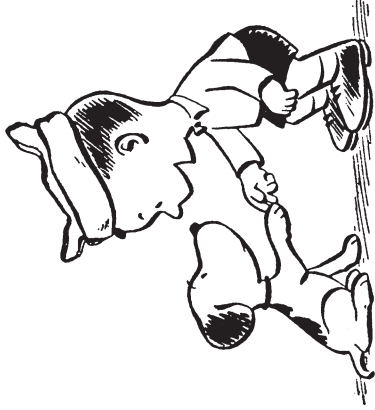

"BROWN'S THE NAME...
CHARLIE BROWN... ALWAYS
GLAD TO GREET A FELLOW
CONSTITUENT!"

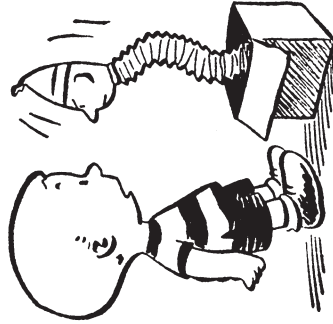

"WHOOPS!...
PARDON ME!"

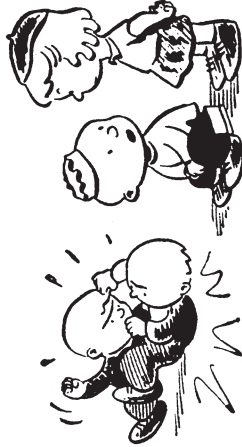

"IT ALL STARTED WITH AN
ARGUMENT OVER WHO HAD
THE WORST TEMPER"

Lil' Folks

BY SPARKY

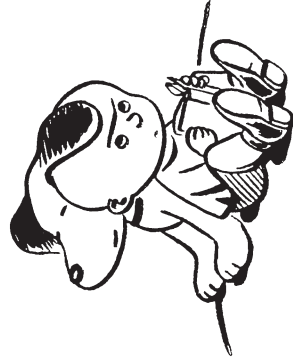
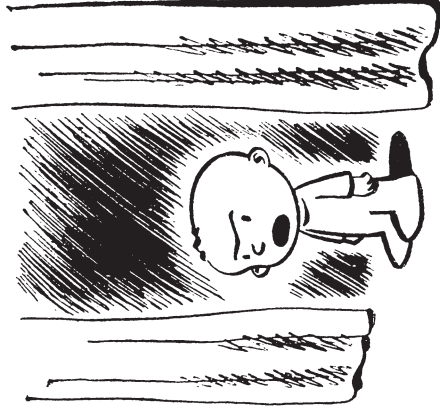

"THERE ARE EIGHT
COLLIES FIGHTING IN MY
BED.... I WISH YOU'D
HAVE THEM REMOVED!"

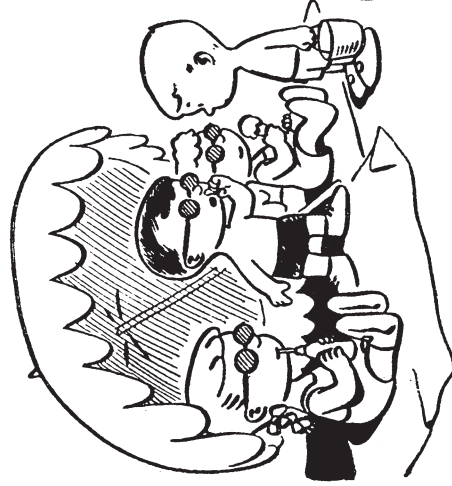

"SHH... DON'T GIVE
ME AWAY.... NEITHER ONE
KNOWS THAT THE OTHER
IS HERE!"

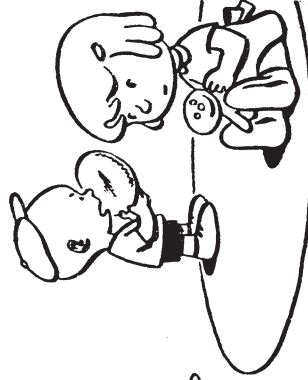

"WHO PUT PERFUME
ON MY CATCHER'S
MITT ?!"

Lil' Folks

BY SPARKY

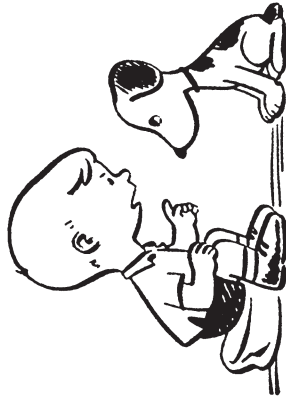

"YOU DON'T SEEM TO REALIZE THAT AS MAN'S BEST FRIEND YOU HAVE CERTAIN OBLIGATIONS TO FULFILL."

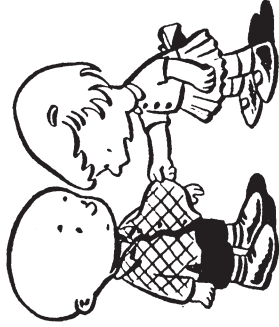

"THAT'S A VERY NICE LOOKING SHIRT ALTHOUGH IT WOULD PROBABLY LOOK EVEN BETTER ON ME!"

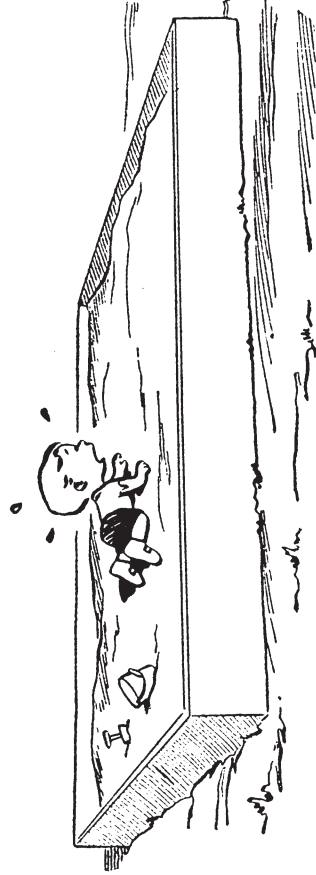

"WATER!...."

Lil' Folks

BY SPARKY



"WELL, DON'T JUST
STAND THERE....GROW!"

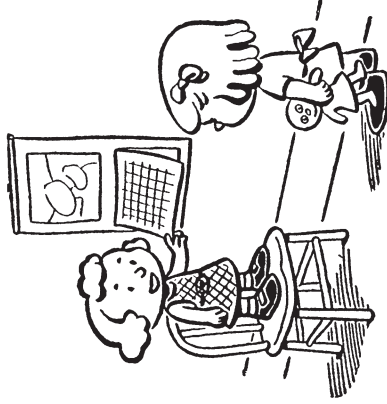

"MY NAME IS JUNE, I WAS
BORN IN JUNE AND MY
BIRTHDAY'S IN JUNE....
ISN'T THAT REMARKABLE?"

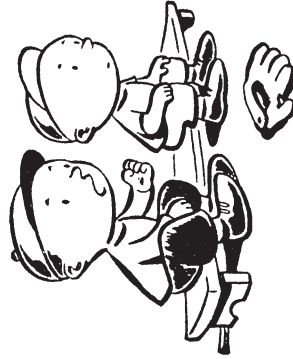

"WE'VE STILL GOT A
CHANCE...GRANDMA'S
GOING IN AS A
PINCH-HITTER!"

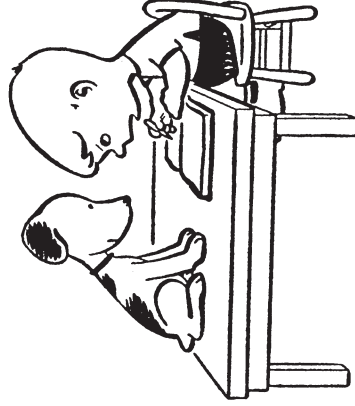

"APPARENTLY YOU
DON'T REALIZE THAT A
DIARY IS A VERY
PERSONAL THING!"

Lil' Folks

BY SPARKY

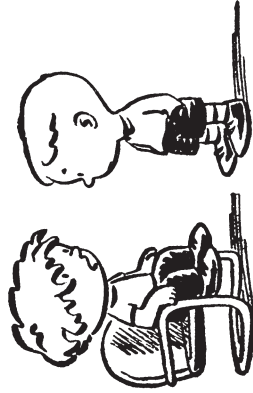

"I DON'T UNDERSTAND....
AS SOON AS I CAME IN
HERE, ALL THREE BARBERS
WENT OUT TO LUNCH!"

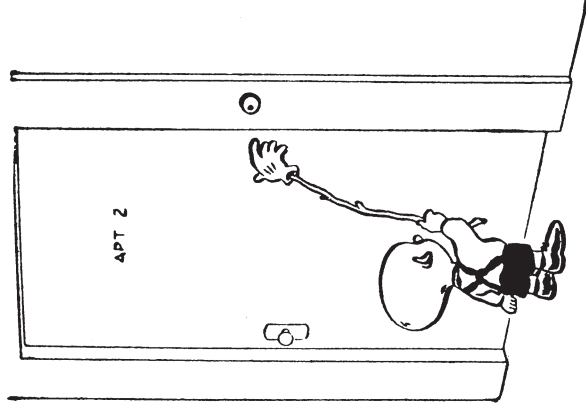

"HOW DO YOU KNOW THAT
YOU REALLY LOVE ME?
MAYBE YOU'RE JUST
FASCINATED BY MY
WORLDLY BACKGROUND"

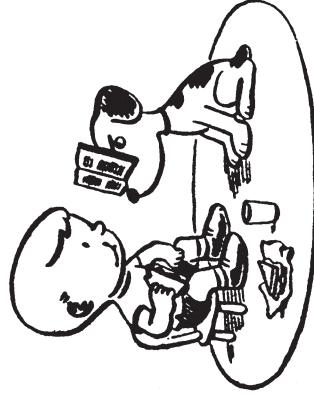

Lil' Folks

BY SPARKY

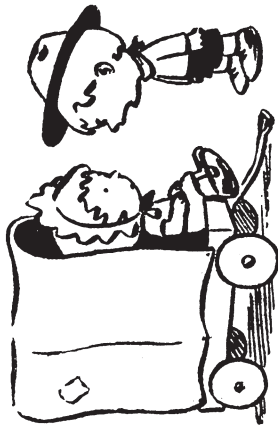

"I'LL BET THE PIONEER LADIES
NEVER COMPLAINED WHEN THEY
COULDN'T HAVE AN ICE CREAM
CONE!"

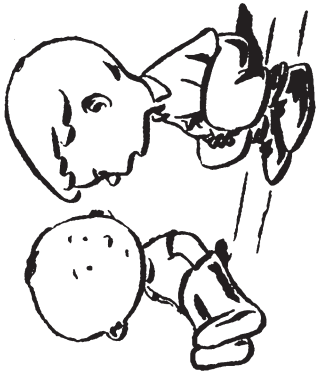

"WHY SHOULD I SAY
SOMETHING FUNNY? I
DON'T GET ANYTHING
OUT OF IT!"

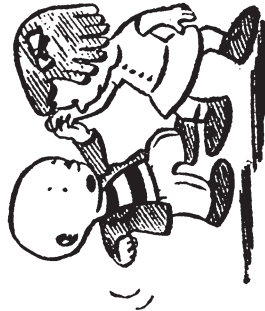
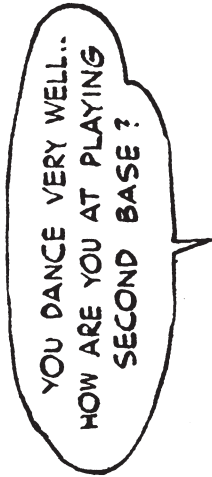
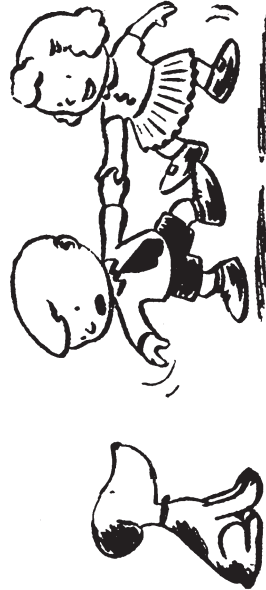

Lil' Folks

BY SPARKY

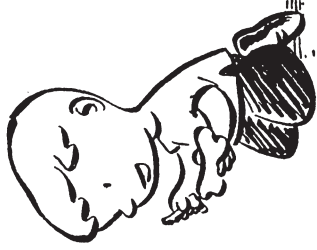
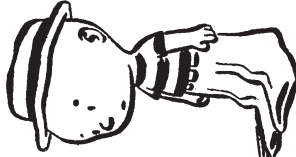
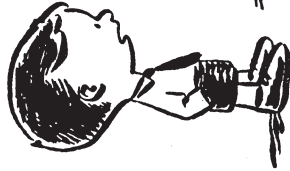

"OF COURSE I THINK
THEY'RE NICE. IT'S JUST
THAT I PREFER A SLIGHT
BREAK AT THE CUFF!"

"YOU MAY HAVE THE PORK
CHOP BONE OR THE HAM
BONE THE LATTER, BY THE
WAY, IS OUR LARGE
ECONOMY SIZE..."

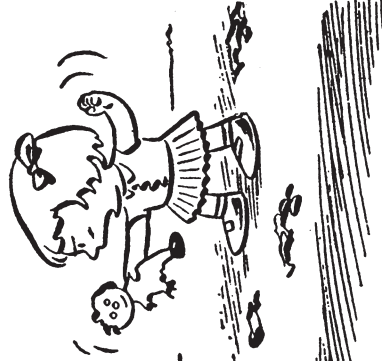
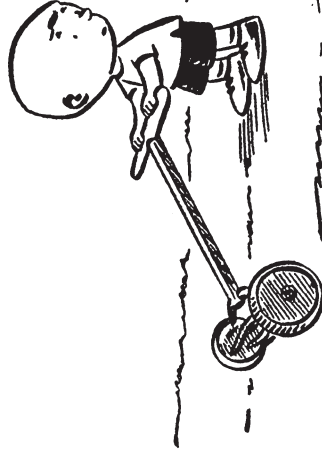

" YOU... YOU... YOU... MURDERER !! "

Lil' Folks

BY SPARKY

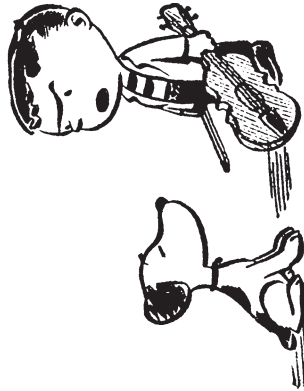
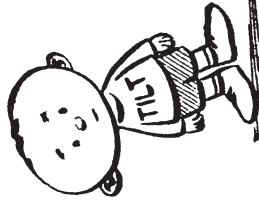

" IN RESPONSE TO NO
REQUESTS I WILL NOW
PLAY ONE OF MY
OWN COMPOSITIONS ! "

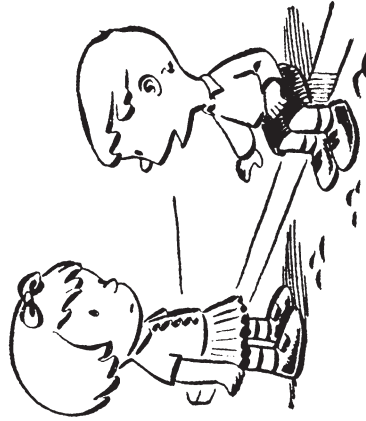

" SIT RIGHT HERE,
YOUNG LADY, AND I SHALL
RELATE TO YOU THE
WONDERS OF THE EAST ! "

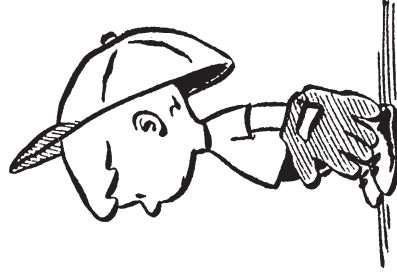

Lil' Folks

BY SPARKY



"LET GO!! I DON'T CARE IF YOU DO HATE THE COLOR! LET GO, I SAY!"

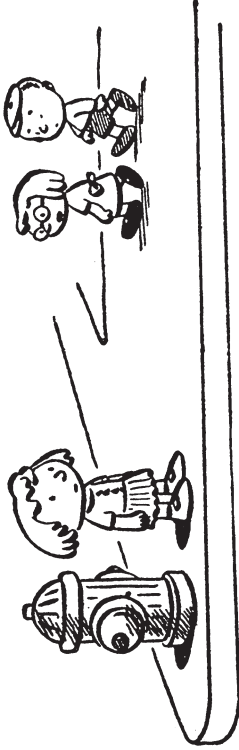

"MY, WHAT A FINE LOOKING YOUNG COUPLE..."

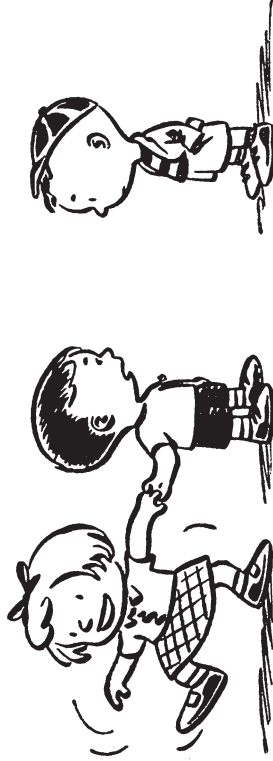

"OH, SURE, WE GET ALONG WELL ENOUGH...IT'S JUST THAT OUR PERSONALITIES AREN'T QUITE THE SAME"

Lil' Folks

BY SPARKY



"I WISH YOU'D TRY
TO REGARD ME AS
SOMETHING BESIDE AN
EARTHLY BENEFACTOR!"

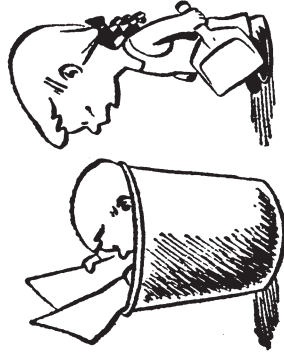

"OH, I'M SORRY...
I DIDN'T KNOW YOU
WANTED ME TO SAVE
THE FUNNIES."

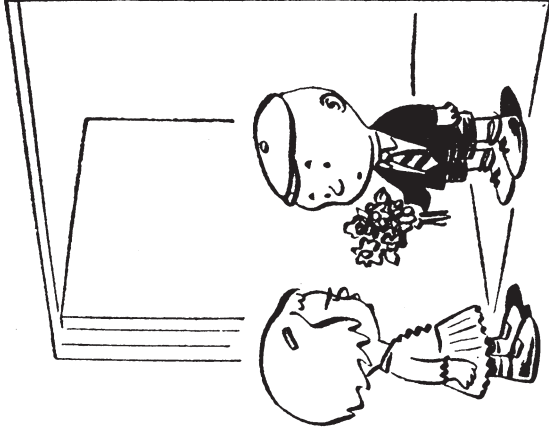

"OH, RATS, I WAS
HOPING YOU'D BRING
HAMBURGERS!"

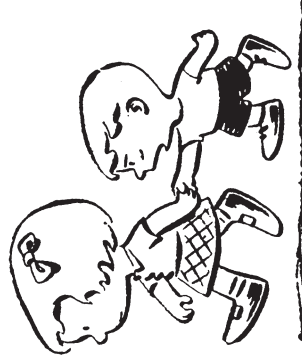

"SLOW DOWN A BIT... I'M NOT
AS SPRY AS I USED TO BE!"

Lil' Folks

BY SPARKY

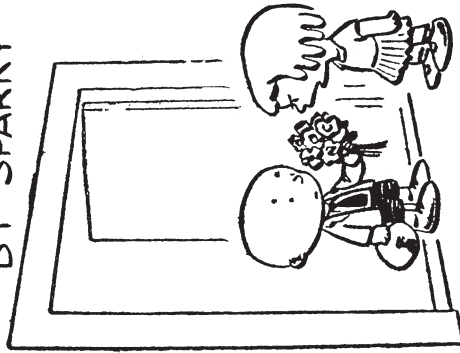

"FLOWERS... SHMOWERS!"

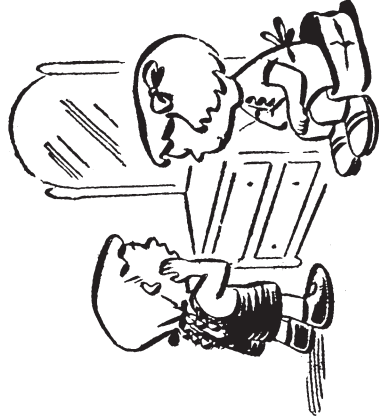

"THIS IS TRAGIC.
IF MY SUN-TAN DISAPPEARS,
MY WHOLE PERSONALITY
IS SHOT !!"

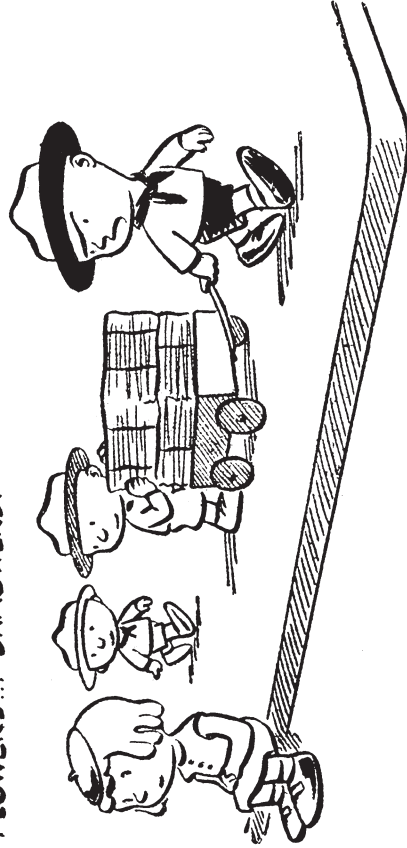

"ALL RIGHT, MEN, LET'S TRY TO
REMEMBER THAT WE HAVE A JOB TO DO!"

Lil' Folks

BY SPARKY

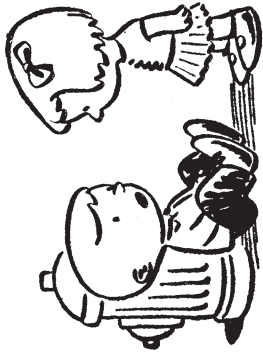

"I LIKE IT HERE... BESIDES,
IF THERE'S A FIRE, I'LL
BE RIGHT IN THE MIDDLE
OF ALL THE ACTION!"

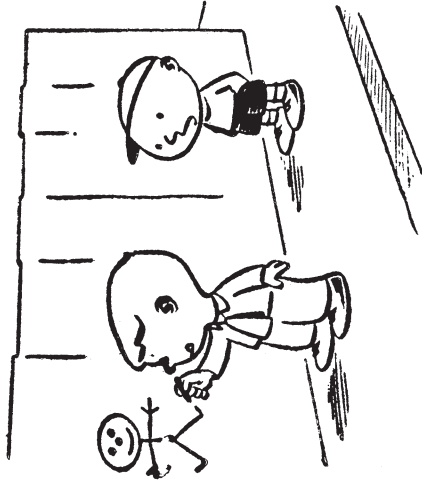

"I THINK YOU'D DO
BETTER ACROSS THE STREET.
THE WOOD IN THE FENCE IS
OF MUCH HIGHER QUALITY!"

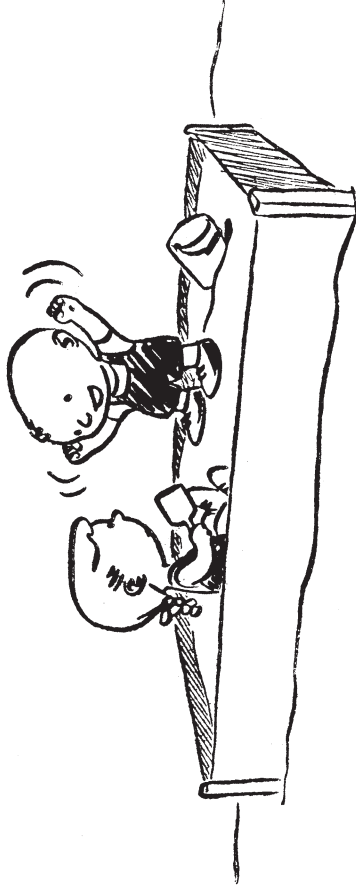

"YES, SIR, THIS IS THE LIFE FOR ME !.....
BACK TO THE SOIL !!"

Lil' Folks

BY SPARKY



"HE'S RAPIDLY TURNING
OUR HOME INTO A DEN
OF INIQUITY!"

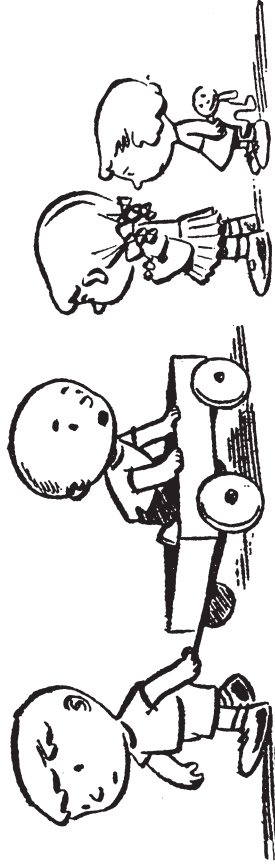

"DON'T CRY...WE WERE JUST KIDDING
I'M NOT REALLY BEING TAKEN TO
THE BASTILLE!"

Lil' Folks

BY SPARKY



"PLEASE... IT'S
BRAND NEW!"

"YOU'RE SO INTELLIGENT,
AND I'M SO TIRED OF
IT ALL!"

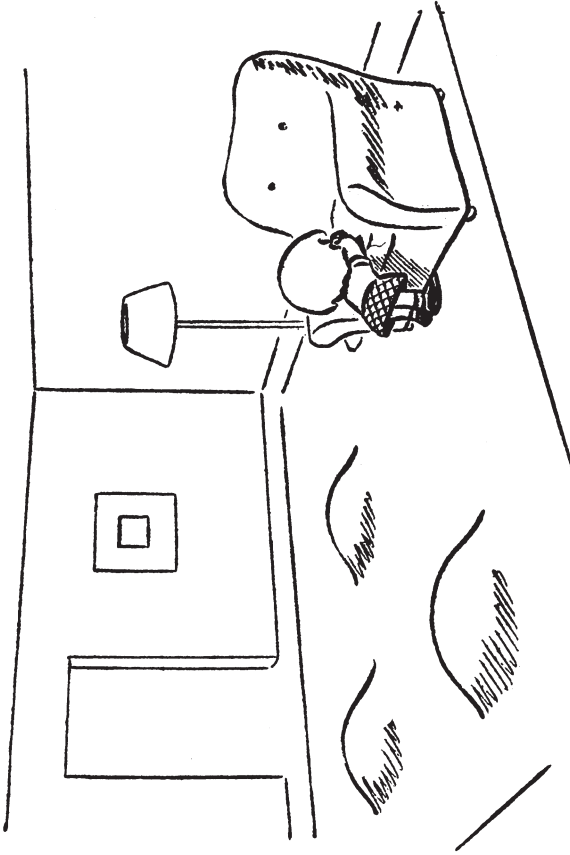

"FORTY-EIGHT, FORTY-NINE, FIFTY! HERE I COME, READY OR NOT!"

Lil' Folks

BY SPARKY

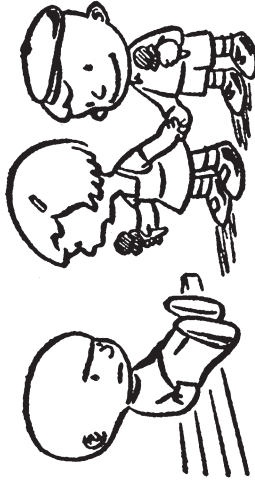

"DON'T BE JEALOUS...WHEN THIS ICE-CREAM IS GONE, I'LL PROBABLY COME BACK TO YOU!"



"MY NAME IS CHARLIE BROWN...I CAN WHISTLE THE ENTIRE SCORE FROM 'DIE FLEDERMAUS'..... WHAT CAN YOU DO?"

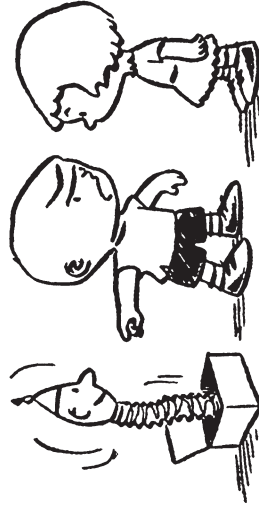

"HA! I KNEW WE WEREN'T ALONE!!"



Lil' Folks

BY SPARKY

September 12, 1948

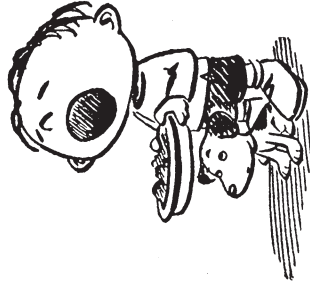

"ROVER! ROVER!!
HERE, ROVER!"

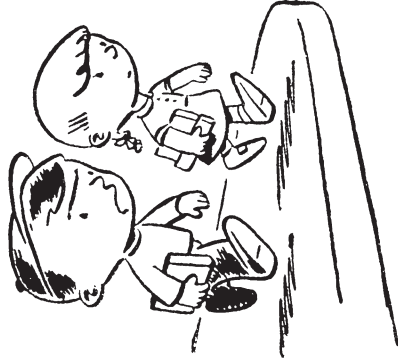

"BACK TO SCHOOL!
PERSONALLY, I THINK
WE'RE JUST BEING
SLAVES TO A
SILLY CUSTOM!"

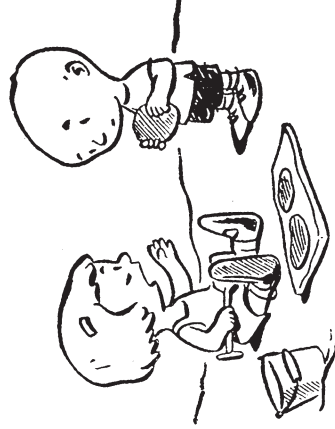

"WAIT !! DON'T EAT
THAT MUD-PIE.... IT
FELL IN THE DIRT!"

Page 235

Lil' Folks

BY SPARKY

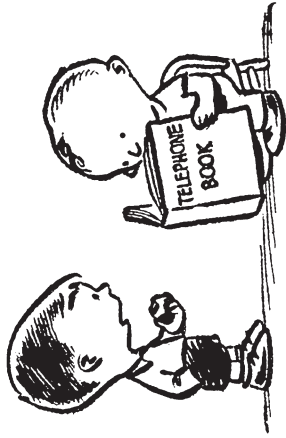
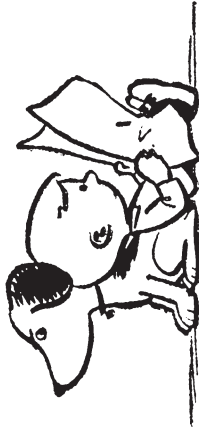

"I ONCE TRIED READING THAT MYSELF, BUT THERE WERE SO MANY CHARACTERS I NEVER GOT PAST THE FIRST CHAPTER!"

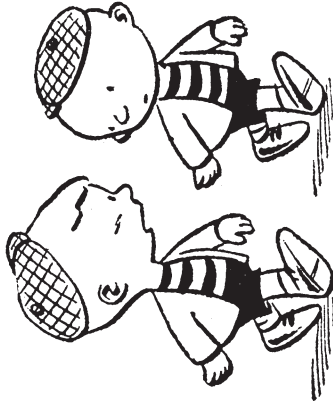

"I DON'T KNOW WHERE I GOT THE IDEA, BUT I HAVE A FEELING THAT YOU AND I HAVE A LOT IN COMMON!"

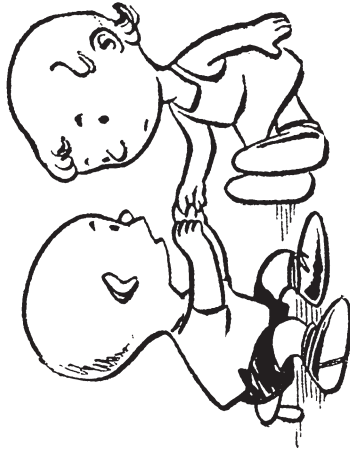

"YOUR EYES,...
YOUR HAIR,...
YOUR TOOTH!"

Lil' Folks

BY SPARKY

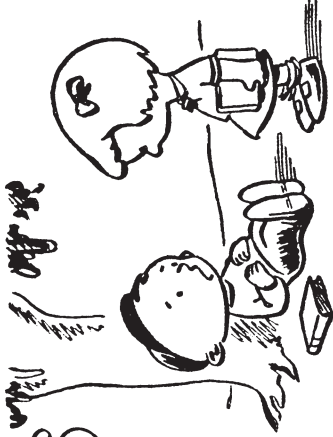

"WOULD I BE BUCKING
TRADITION TOO MUCH IF
I RELAXED NOW, AND
WENT TO SCHOOL LATER
IN MY OLD AGE?"

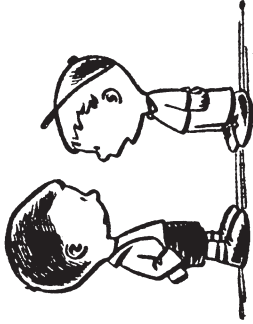

"I'VE COME TO YOU
BECAUSE I NEED THE
ADVICE OF AN OLDER MAN."

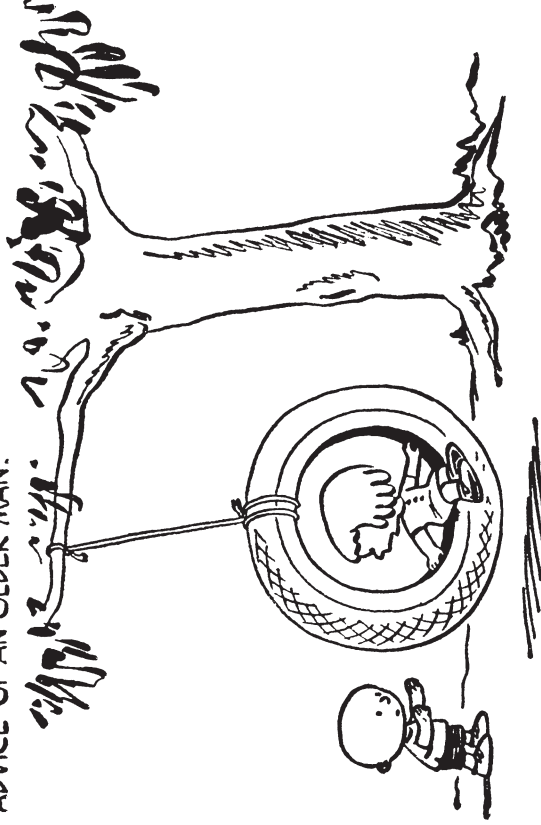

"NOT TOO FAST NOW... I'M SCARED TO DEATH OF A BLOWOUT!"

Lil' Folks

BY SPARKY



"OH, I'M SORRY....
I SHOULD HAVE WARNED
YOU THAT HE BITES!"

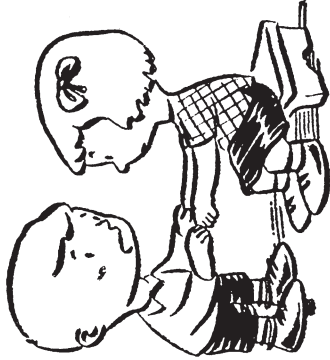

"YOUR EYES, YOUR HAIR,
YOUR ANSWERS TO THE
HISTORY TEST QUESTIONS!"

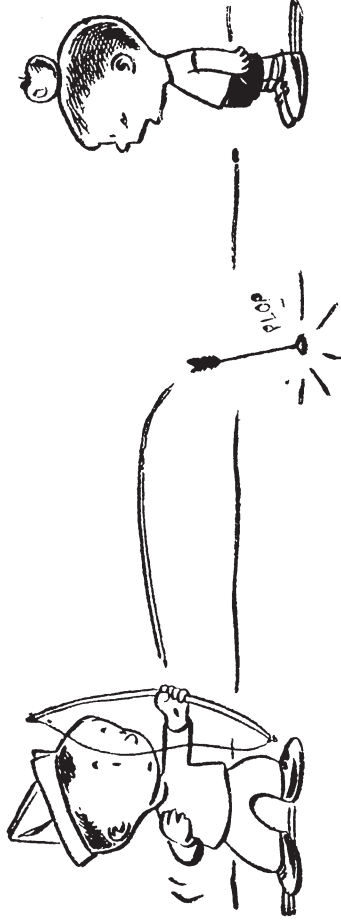

"THERE'S NO DOUBT IN MY MIND THAT UP TO NOW I'VE
BEEN DOING A LOT OF WORRYING FOR NOTHING!"

Lil' Folks

BY SPARKY

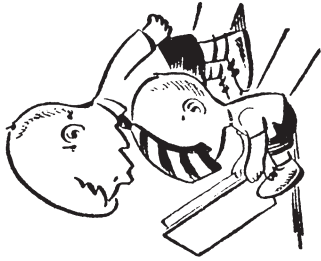

"PLEASE GO ON...DON'T STOP
READING BECAUSE OF ME!"

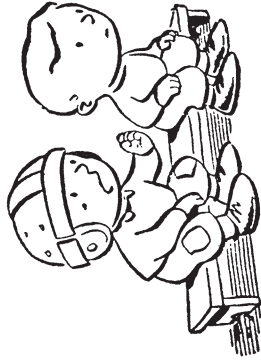

"WE'VE STILL GOT
A CHANCE....
GRANDMA'S GOING IN
AT FULLBACK!"

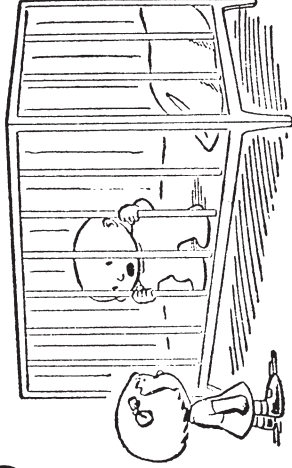

"THE NEXT TIME YOU COME SEE IF
YOU CAN SLIP ME A RATTLE
WITH A FILE IN IT!"

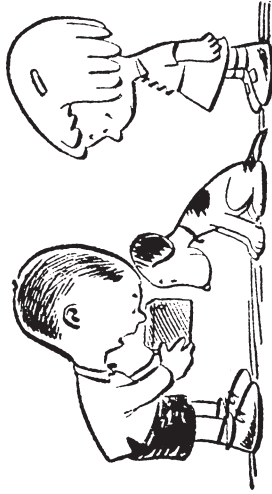

" I DON'T UNDERSTAND...
ALL I CAN SEE IS
SOMETHING THAT APPEARS
TO BE A BIG EYE ! "

Lil' Folks

BY SPARKY



"GIRLS NEED UMBRELLAS MORE
THAN BOYS...GIRLS ARE MADE
OF SUGAR AND SPICE!"

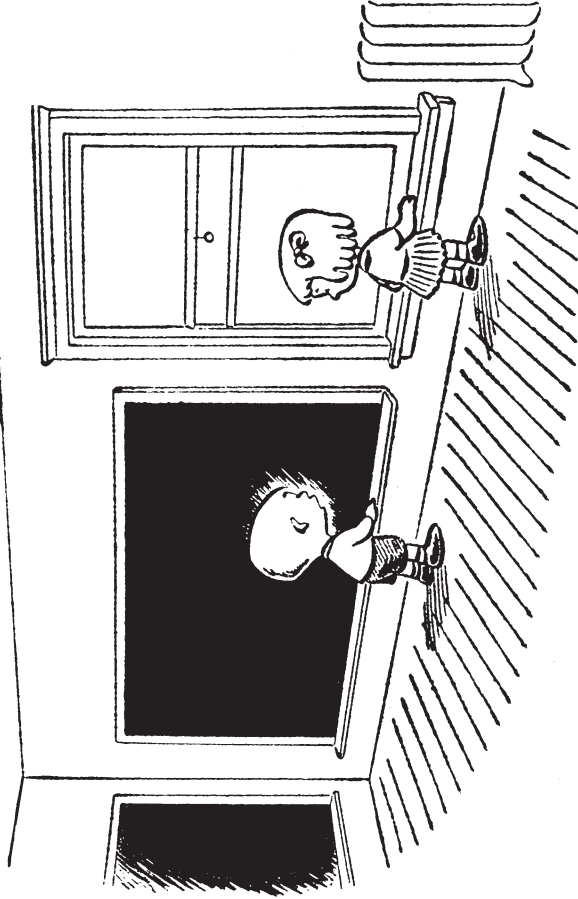
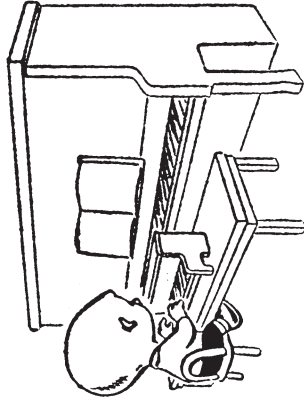

"BOY! IS IT EVER DARK OUTSIDE!"

Lil' Folks

BY SPARKY

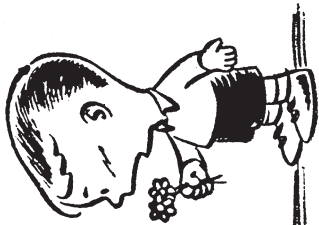
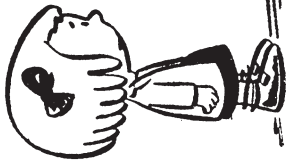
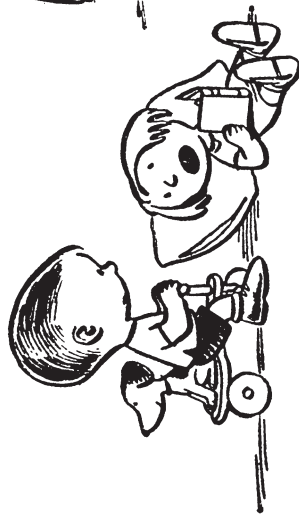

"ALL RIGHT, SO YOU'VE
KNOWN ME FOR ONLY
TWO YEARS! CAN I
HELP IT IF I'VE BEEN
ALIVE FOR ONLY
THREE?!"

"GO AHEAD, AND RUN
OVER ME... I'M WEARY
OF IT ALL ANYWAY.."

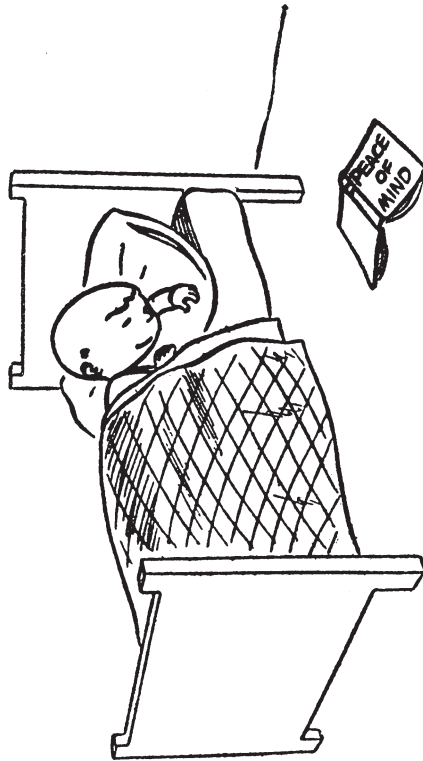

Lil' Folks

BY SPARKY

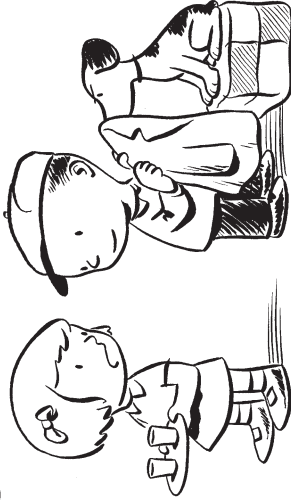
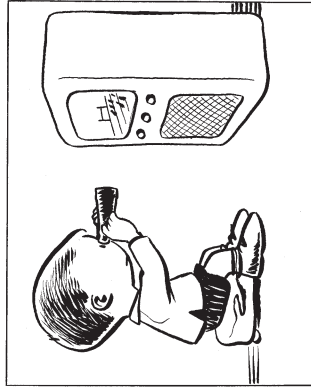

" JUST HANG YOUR COAT
ANYWHERE, AND MAKE
YOURSELF TO HOME."

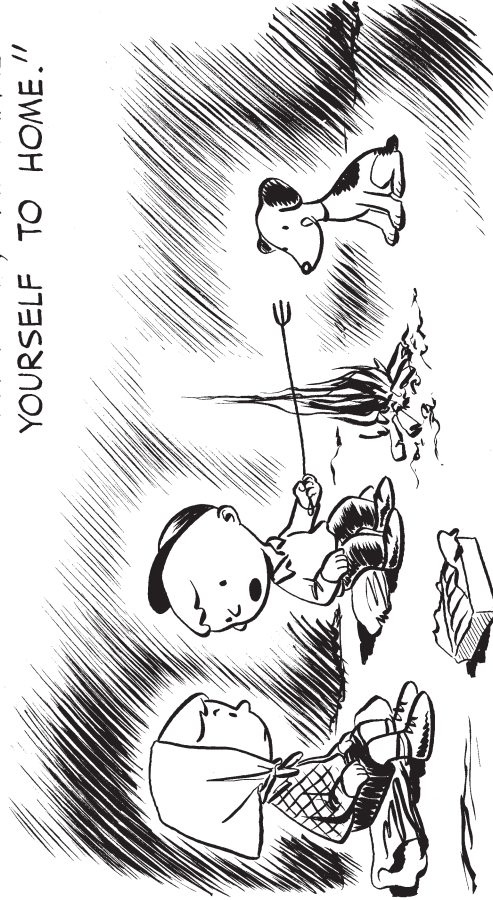

" TRY TO BE MORE PATIENT...WEINERS
DON'T ROAST IN A SECOND, YOU KNOW!"

Lil' Folks

BY SPARKY



"WHY DON'T YOU TRY REASONING WITH HIM?"

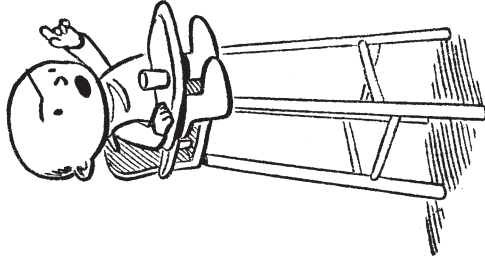

"CHECK, PLEASE!"

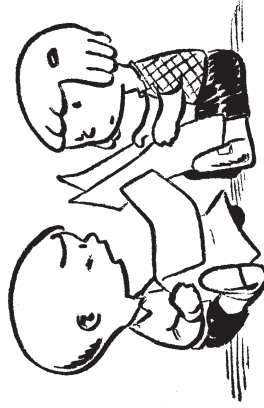

"FROM WHAT I'VE BEEN HEARING LATELY, WE'RE NOT MISSING MUCH BY NOT KNOWING HOW TO READ!"

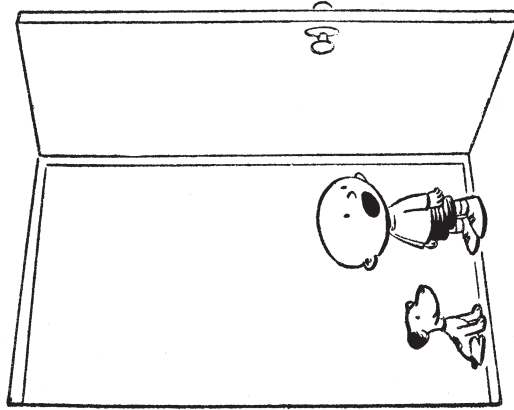

"BETTER PUT ON ANOTHER LAMB CHOP...!! WE'VE GOT COMPANY!!"

Lil' Folks

BY SPARKY

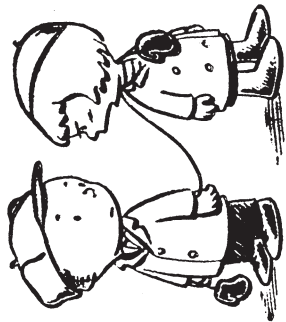

"PLEASE!"

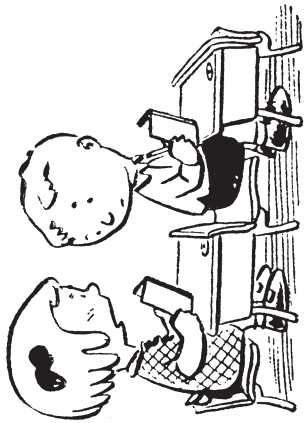

"I DREAMED ABOUT
YOU LAST NIGHT....
RUINED A GOOD
NIGHT'S SLEEP!"

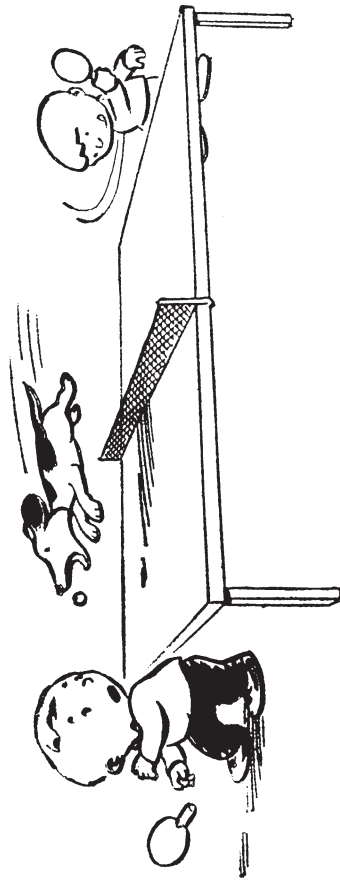

Lil' Folks

BY SPARKY

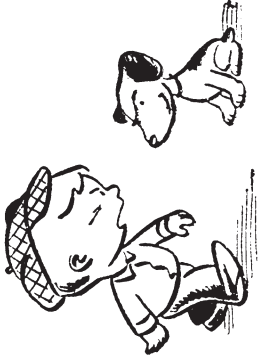

"IF YOU WERE REALLY
MAN'S BEST FRIEND,
YOU WOULDN'T SNEER
AT ME EVERYTIME I
WALK BY !!"

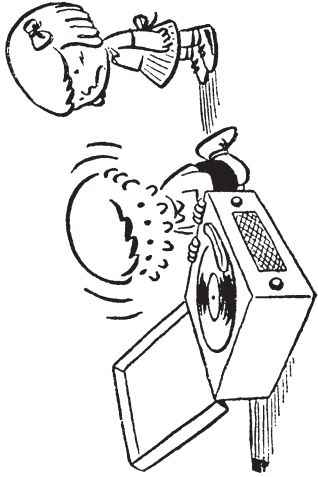

"ALL RIGHT, IF YOU MUST KNOW
WHAT'S PLAYING, GO AHEAD, AND
STOP THE RECORD!"

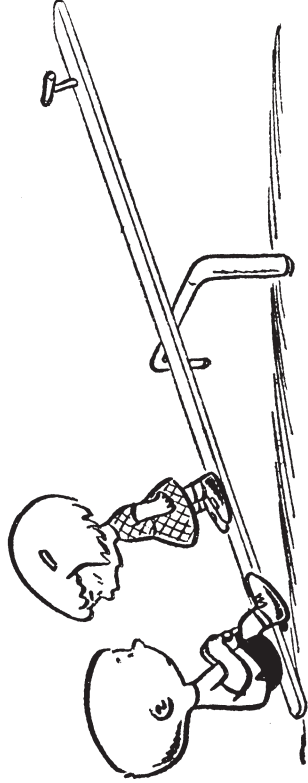

" I GOT LONESOME !"

Lil' Folks

BY SPARKY

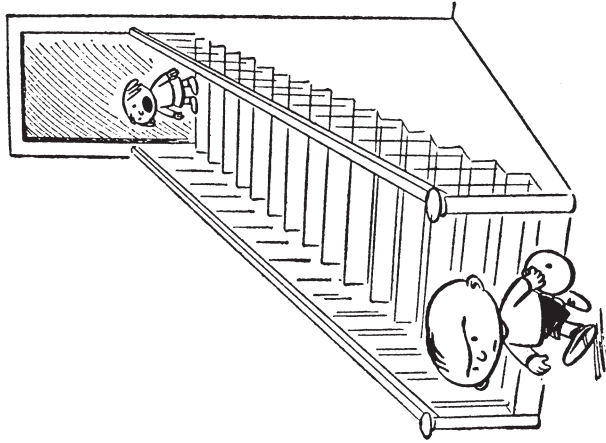
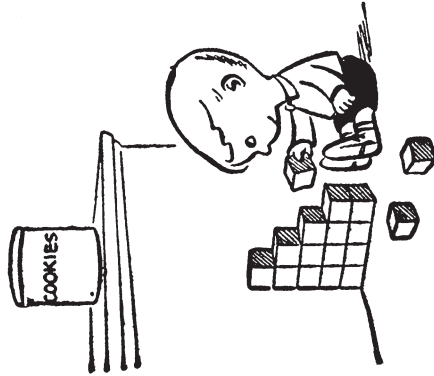

"STICKS AND STONES MAY BREAK
MY BONES, BUT NAMES WILL NEVER
HURT ME.....YOU BONEHEAD!
YOU NUMSKULL! YOU BIRDBRAIN!"

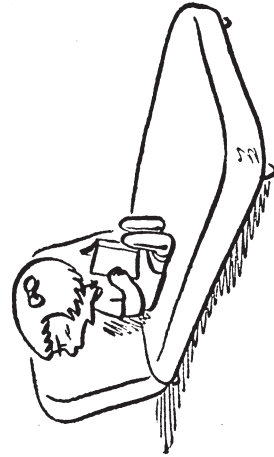

"STOP SAYING, 'LOVE ME, LOVE MY DOG!'"

Lil' Folks

BY SPARKY



"GROW, YOU FOOL !!
YOU'VE GOT A DEADLINE
TO MEET !"

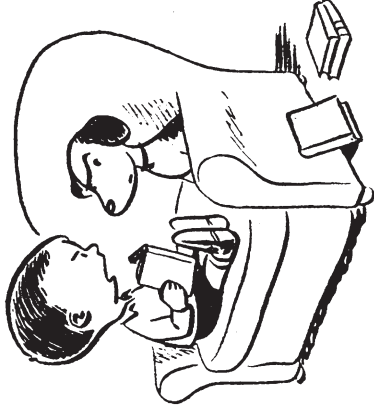

"SUPPOSE WE TRY SOMETHING
ELSE THIS AFTERNOON BESIDES
ALBERT PAYSON TERHUNE !"

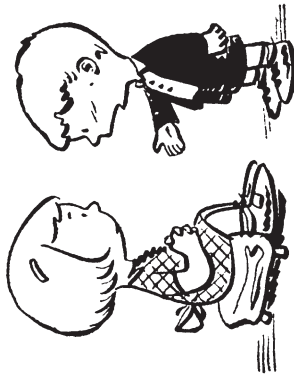

"WHY WAIT UNTIL AFTER
I GRADUATE? LET'S GET
MARRIED NOW BEFORE I
EVEN START SCHOOL !"

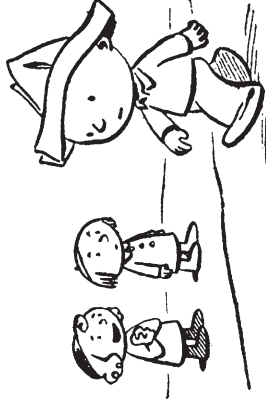

"THERE'S SOMETHING
ABOUT A UNIFORM THAT
ALWAYS THRILLS ME !"

Lil' Folks

BY SPARKY

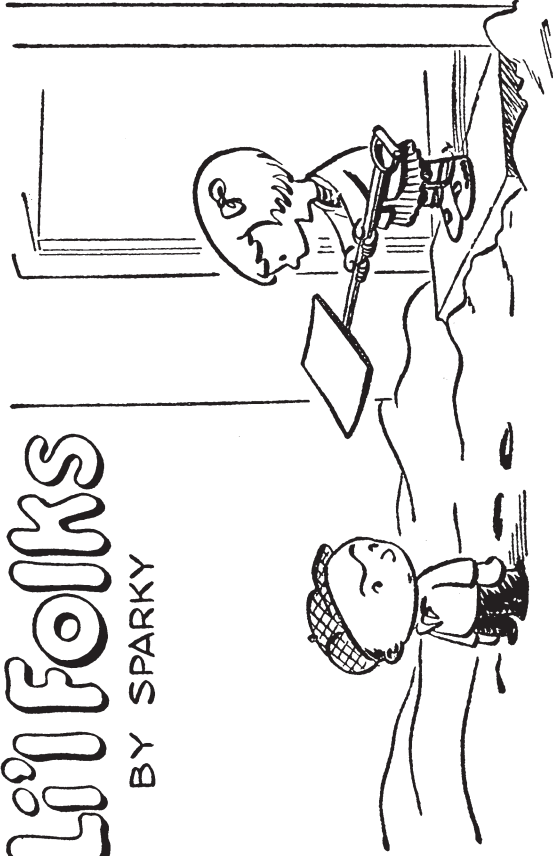

" HERE, TAKE IT.... THEY SAY IT'S SO SIMPLE, EVEN A CHILD CAN OPERATE IT! "

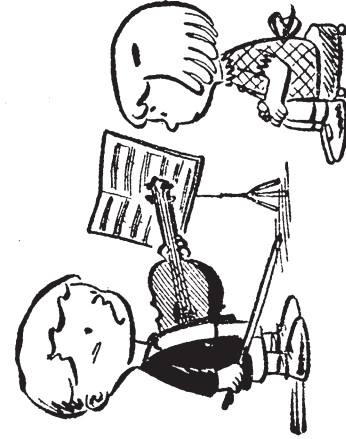

" BEETHOVEN AND I CAN'T SEEM TO AGREE ON ANYTHING! "

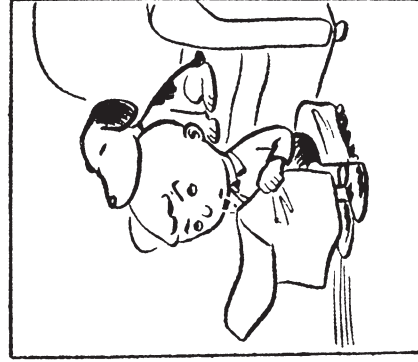

Lil' Folks

BY SPARKY

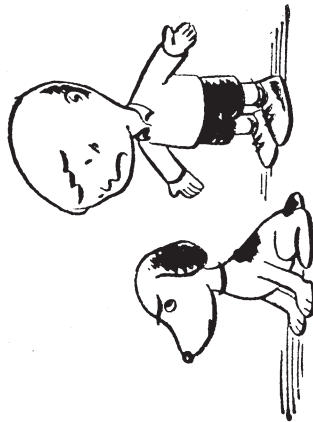
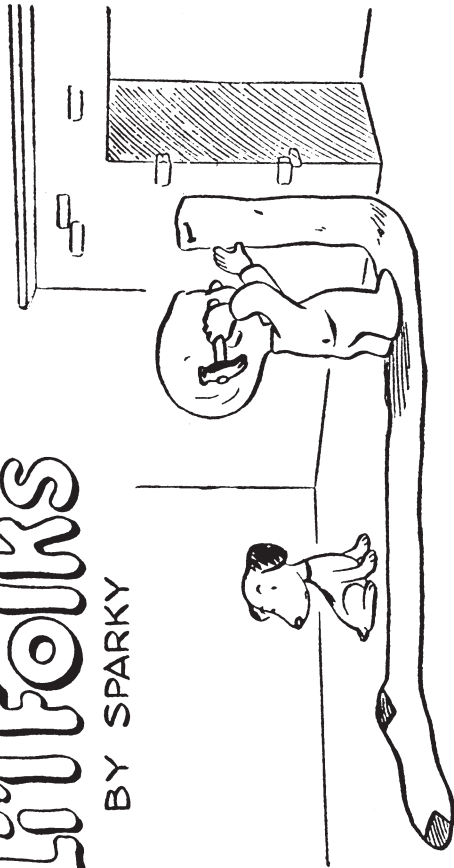

"IF YOU WANT TO GET
MARRIED, WELL, ALL RIGHT....
BUT WHY NOT PICK
SOMEONE RESPECTFUL?"

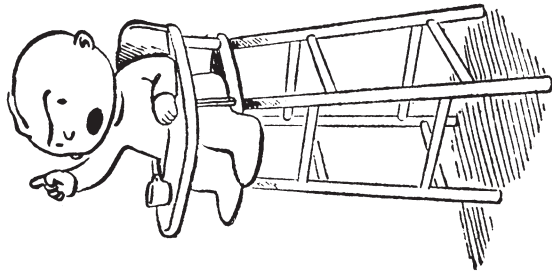

"CAN'T YOU MAKE IT
SNAPPY?... I'VE GOT
A TRAIN TO CATCH!"

L'il Folks

BY SPARKY

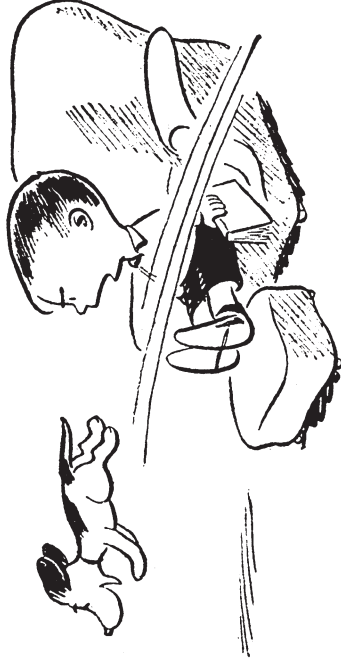

" YOU CAN'T POSSIBLY REALIZE HOW
DISTURBING THAT IS ! "

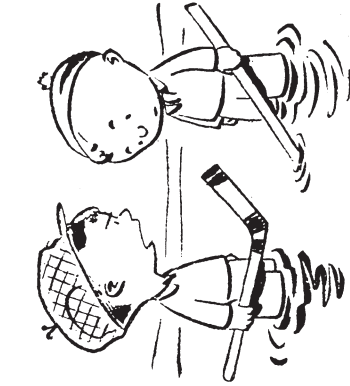

" YOU WERE THE ONE
WHO SAID IT WAS
GOING TO BE FREEZING
TODAY ! "



" AS I SIT HERE
VIEWING THE PASSING
PARADE, I GET THE
FEELING THAT LIFE
HAS PASSED ME BY ! "

L'il Folks

BY SPARKY

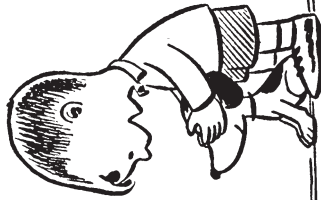

"GUESS WHO !"

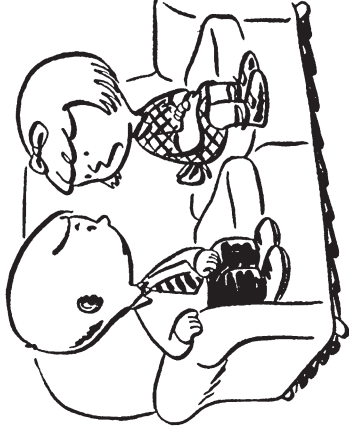

"BORE ME WITH THE
STORY OF YOUR LIFE !"

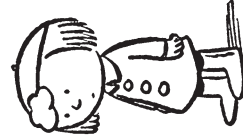
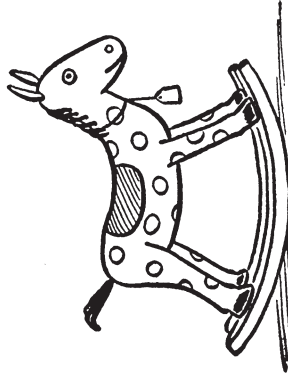

"SURE, I'D LIKE TO HAVE ONE, BUT YOU KNOW HOW
MUCH TROUBLE THEY ARE.. THE FEED BILLS ALONE
WOULD BE ENOUGH TO KEEP YOU BROKE !"

Lil' Folks

BY SPARKY

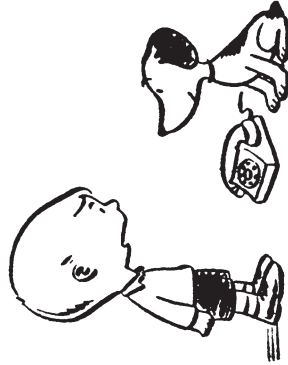

"AND JUST WHAT DO YOU INTEND TO SAY IF 'STOP THE MUSIC' DOES CALL YOU?"

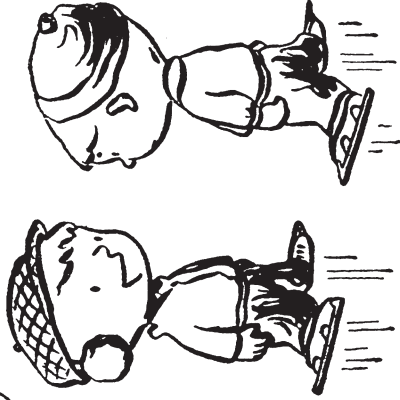

"LET'S JUMP OVER BARRELS!"

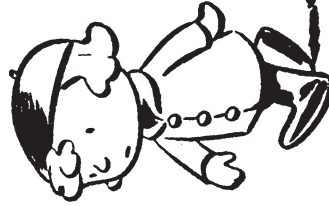
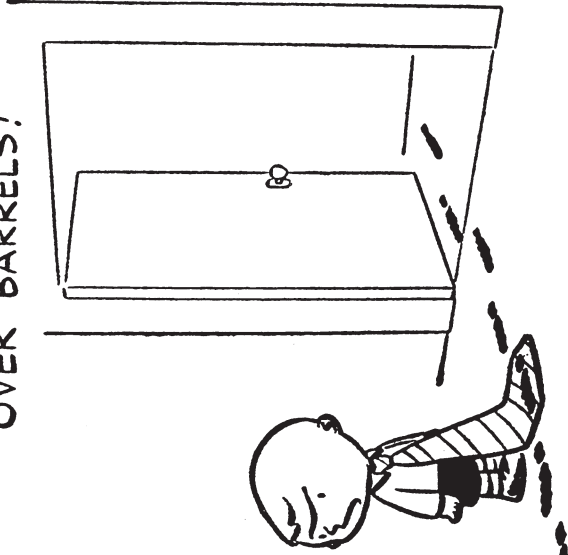

"YOU'RE THE MOST INCONSIDERATE PERSON I'VE EVER KNOWN!"

Lil' Folks

BY SPARKY

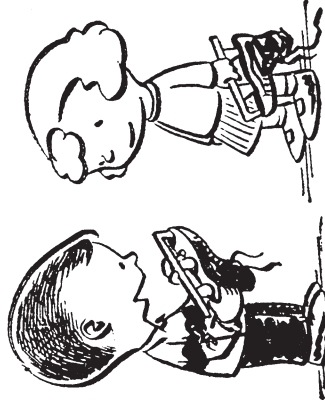
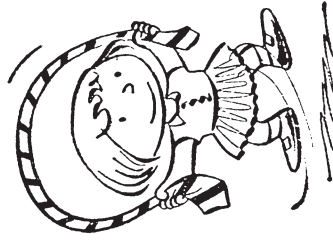

"THERE'S NO DOUBT ABOUT IT...
GRANDMA'S THE BEST SKATE
SHARPENER IN THE BUSINESS."

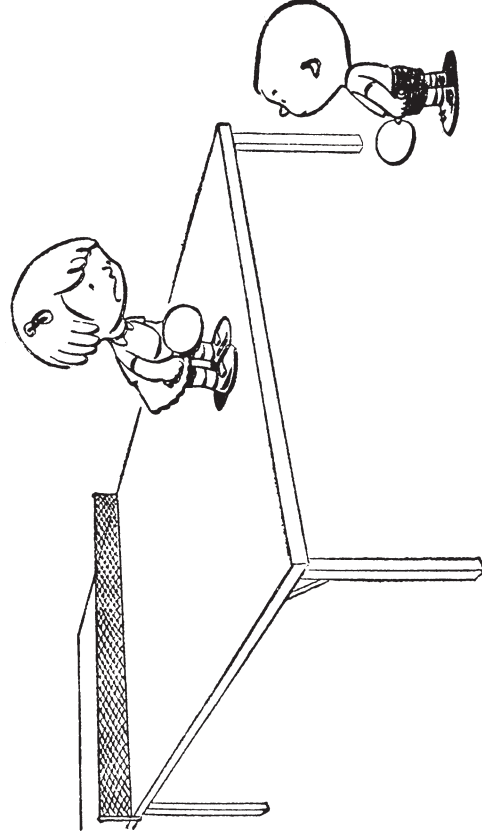

"I WAS WORRIED... I THOUGHT YOU MIGHT HAVE LEFT!"

L'il Folks

BY SPARKY

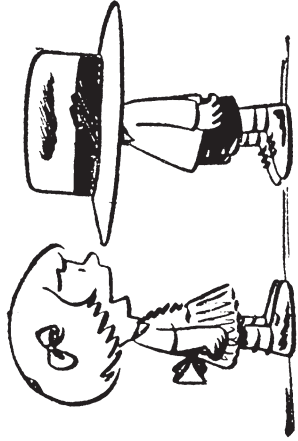

"SEE? NOW YOU LOOK JUST LIKE YOUR FATHER!"



"AGNES? MARIE?
DOROTHY?"

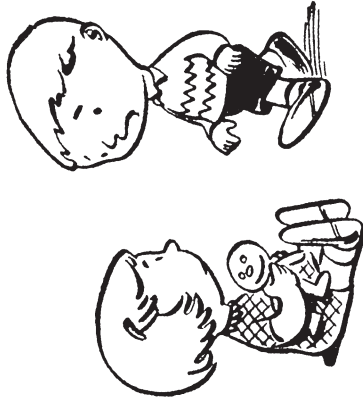

"WOW!! ONE MORE SPANKING LIKE THAT, AND I'LL BE ELIGIBLE FOR THE PURPLE HEART!"



"WELL, THERE'S AT LEAST ONE THING WE MAY SAY FOR CERTAIN....YOU HAVE A HAND!"

Lil' Folks

BY SPARKY

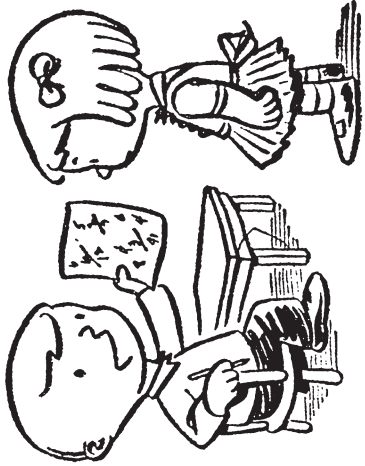
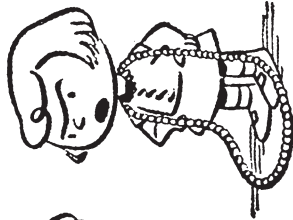

"AND WHAT MAKES
YOU THINK THEY BELONG
TO MY MOTHER?"

"I'VE DISCOVERED WHAT
I THINK WILL BE A
GREAT TIME - SAVER....
NO MORE BATHS!"

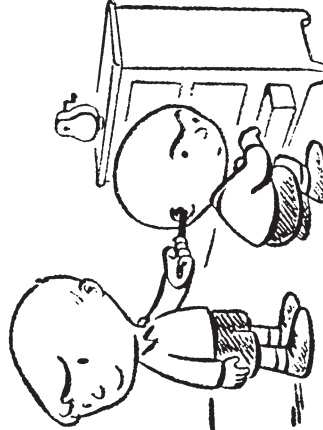
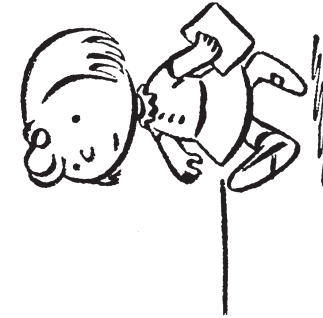

Lil' Folks

BY SPARKY

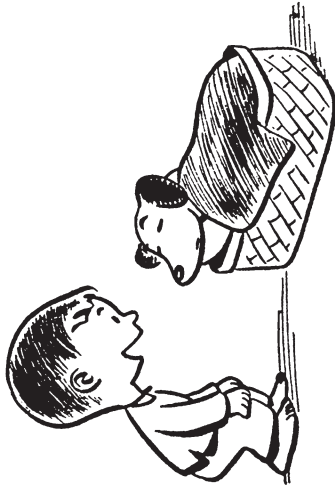

"GOOD MORNING!! WHAT DO YOU SAY TO STARTING OFF THE DAY WITH A SMILE?"

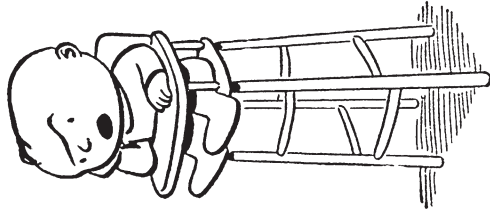

"THE SERVICE IN THIS PLACE GETS WORSE EVERYDAY!"

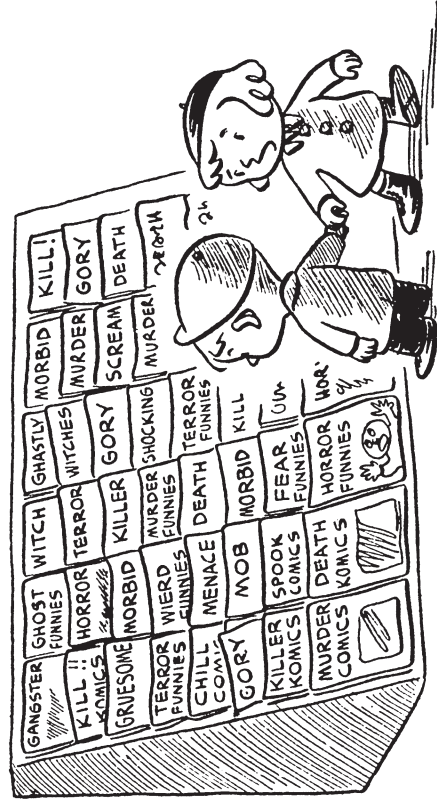

"LET'S GET OUT OF HERE...THIS GIVES ME THE CHILLS!"

Lil' Folks

BY SPARKY



"EDGAR ALLAN POE IS
NOT TO BE TAKEN
SO LIGHTLY!"

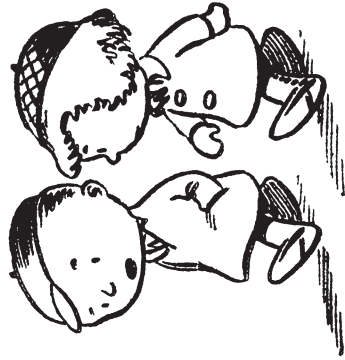

"YESTERDAY YOU FASCINATED
ME... TODAY YOU CONFUSE
ME... I WONDER WHAT
TOMORROW WILL BRING?"

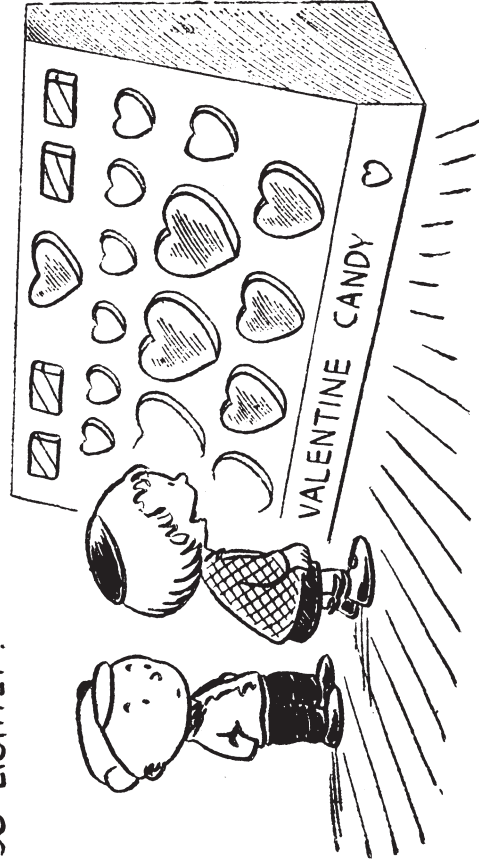

"YES, SIR!! A MOST IMPRESSIVE LOOKING LAYOUT!"

Lil' Folks

BY SPARKY

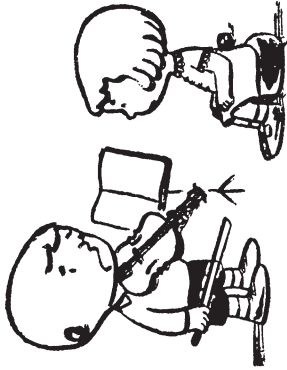

"I'LL BET BEETHOVEN
WOULD HAVE HATED ME!"

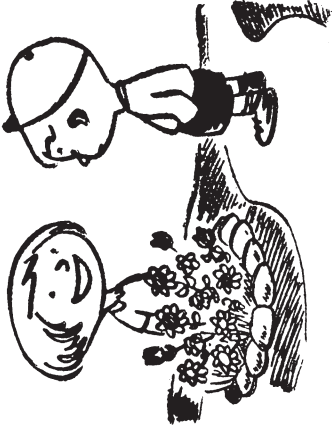

"HERE'S YOUR BIG
CHANCE TO SAY
SOMETHING SWEET!"

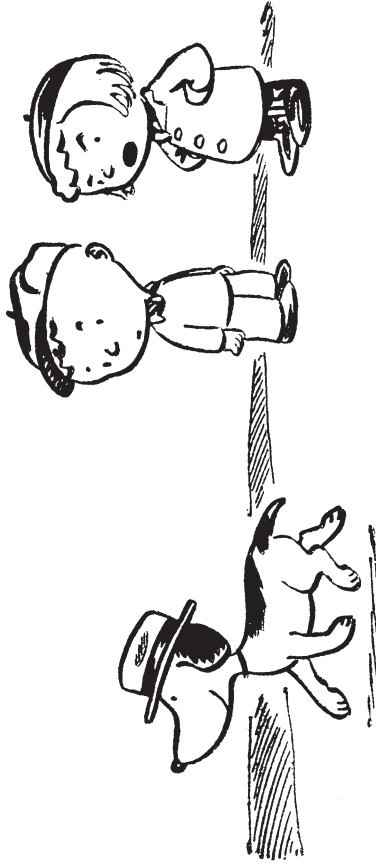

"WELL, HOW DO YOU LIKE THAT?! PASSED US
RIGHT BY WITHOUT SO MUCH AS TIPPING HIS HAT!"

Lil' Folks

BY SPARKY

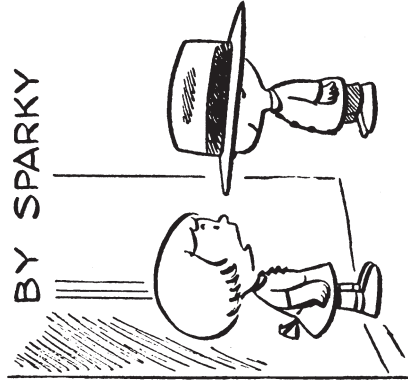

"BOY, AM I GLAD TO SEE YOU!
WHO ARE YOU?"

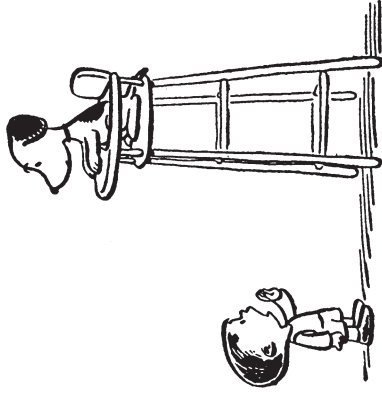

"THAT'S ALL RIGHT...
STAY WHERE YOU ARE...
I'LL EAT LATER."

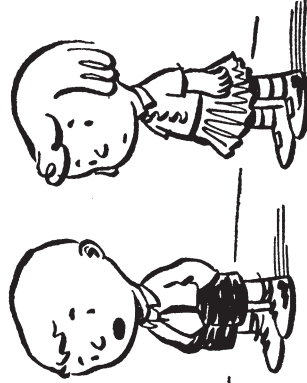
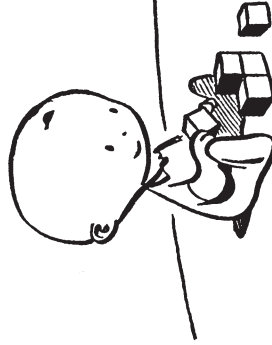

"JUST LOOK AT HIM... NO WORRIES, NO CARES...
HOW I WISH THAT I WERE THAT AGE AGAIN!"

Lil' Folks

BY SPARKY

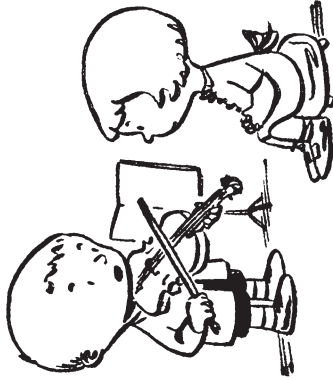

"DO YOU THINK I
COULD HAVE HAD ANYTHING
TO DO WITH THE DEATH
OF BEETHOVEN?"

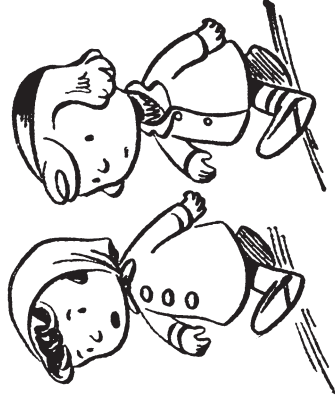

"I'VE LOST ALL MY
AMBITION SINCE I HEARD
THAT A HOUSEWIFE
HASN'T A CHANCE EVER
TO BECOME FAMOUS!"



"I'D LIKE TO LIVE IN
THE SOUTH SO I
COULD MAKE MUD PIES
ALL YEAR 'ROUND!"

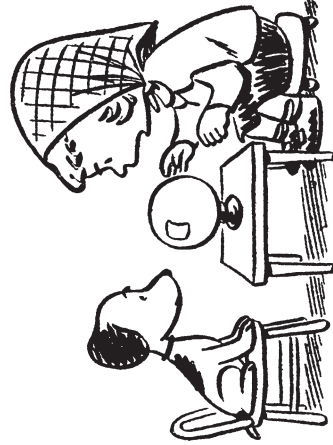

"BEWARE OF A LARGE
BLACK SPANIEL!"

Lil' Folks

BY SPARKY

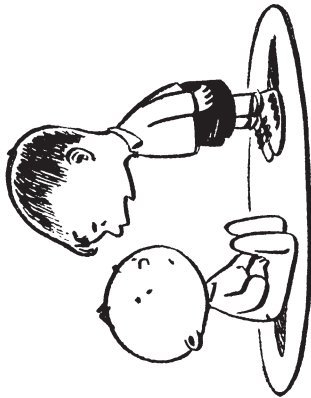

"OH, HOW I TREMBLE WHEN I THINK OF THE GREAT TASK THAT FACES YOUR GENERATION!"

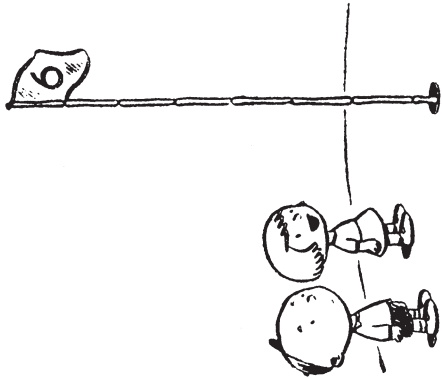

" I THINK THEY'RE BEAUTIFUL... THEY GROW SO TALL AND STRAIGHT"

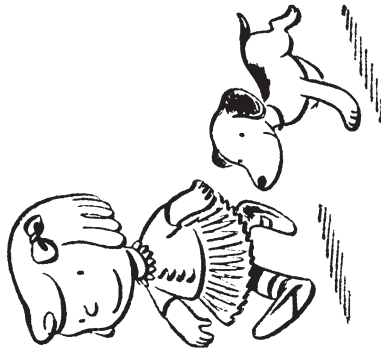
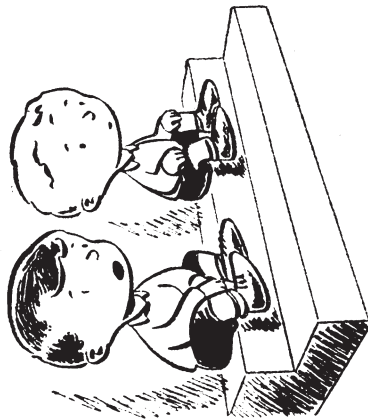

" GIRLS AND DOGS.... UNDOUBTEDLY TWO OF MANKIND'S GREATEST MYSTERIES !"

Lil' Folks

BY SPARKY

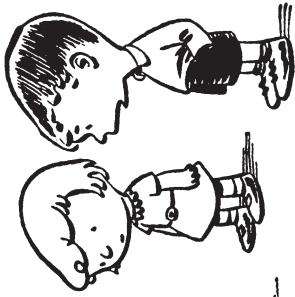
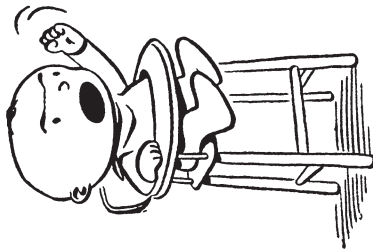

"IT'S VERY SAD....APPARENTLY
HE'S BECOME BORED WITH
HIS MEANINGLESS EXISTENCE!"

"HOW ABOUT SOME SERVICE?!
DO YOU WANT ME TO BE
LATE FOR WORK ?!! "

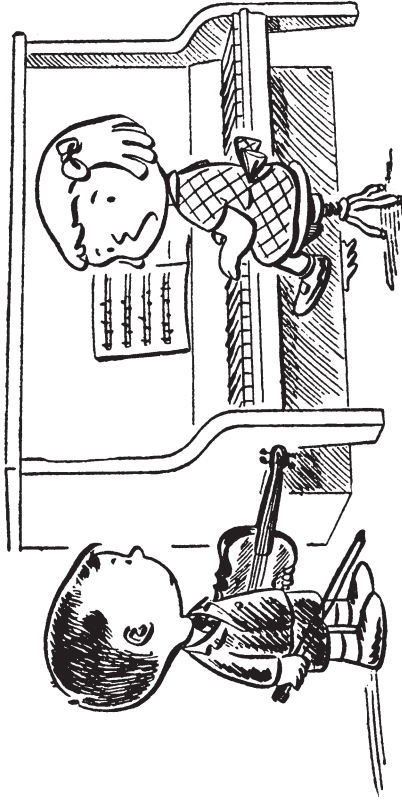

"LAST NIGHT I DREAMED THAT BEETHOVEN STRANGLED ME!"

Lil' Folks

BY SPARKY

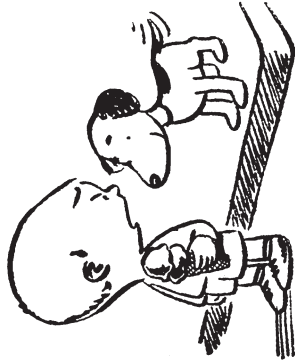

"LET'S NOT OVERDO THIS BUSINESS OF BEING MAN'S BEST FRIEND!"

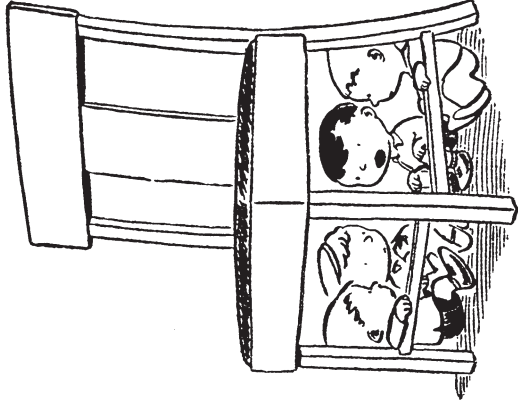

"I MAKE A MOTION THAT WE ALL BEGIN SEARCHING FOR A LARGER CLUB HOUSE!"

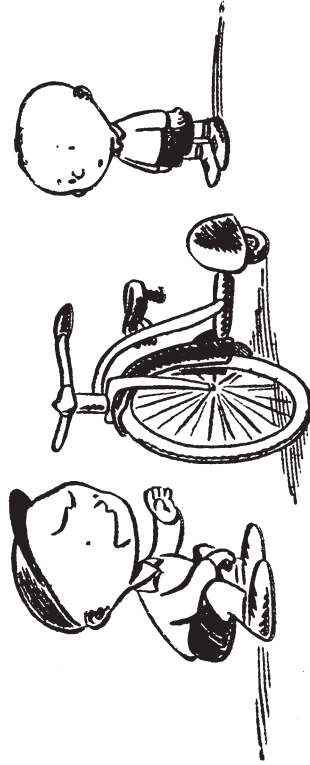

"SAY, I'LL BET WE COULD TURN THIS INTO A PRETTY GOOD HOT-ROD!"

Lil' Folks

BY SPARKY

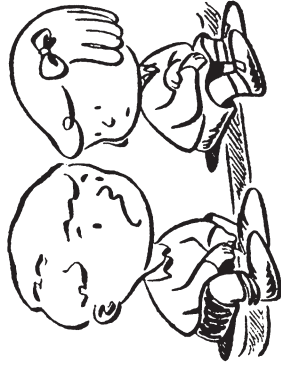

"I'D SORT OF LIKE TO BE
A REGULAR ROUGHNECK,
BUT I'M AFRAID I'M NOT
STRONG ENOUGH!"

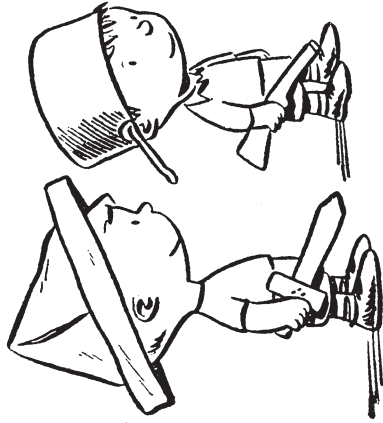

"WHAT'S THIS I HEAR ABOUT YOU GUYS
APPLYING FOR A STATE BONUS?"

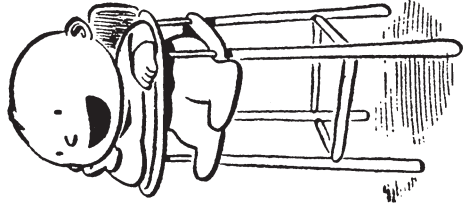

"LET'S SKIP THE BABY
FOOD TODAY, GIRLIE, AND
BRING ME A NICE BIG
T-BONE STEAK!"



Lil' Folks

BY SPARKY

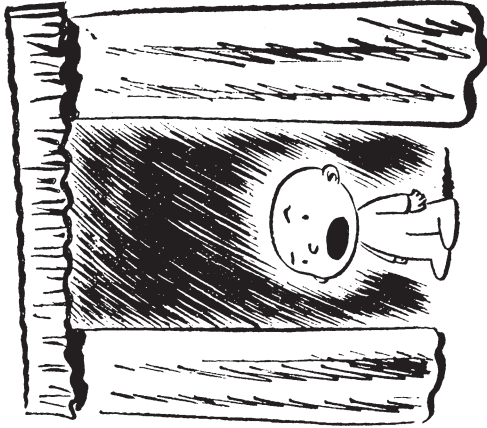
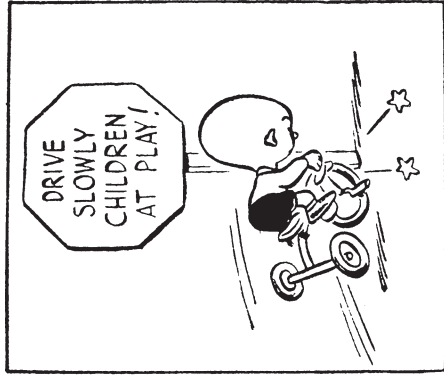

"HOW DO YOU EXPECT
ME TO SLEEP WITH THE
REST OF THE WORLD
TOSSED IN TURMOIL?"

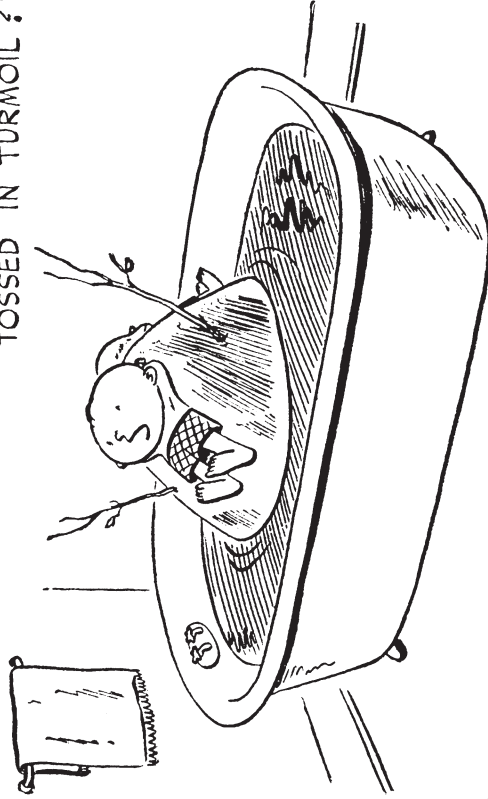

"IF WE GET BORED, WE CAN ALWAYS PULL OUT THE
PLUG, AND HEAD FOR THE MAINLAND!"

Lil' Folks

BY SPARKY

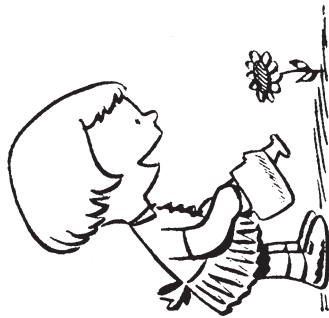

"YOU CAN'T POSSIBLY
IMAGINE HOW GLAD I
AM TO SEE YOU!"

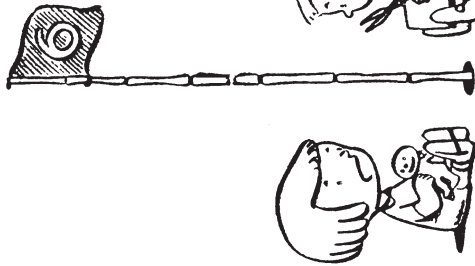

"DO YOU HEAR
SOMEONE YELLING?"

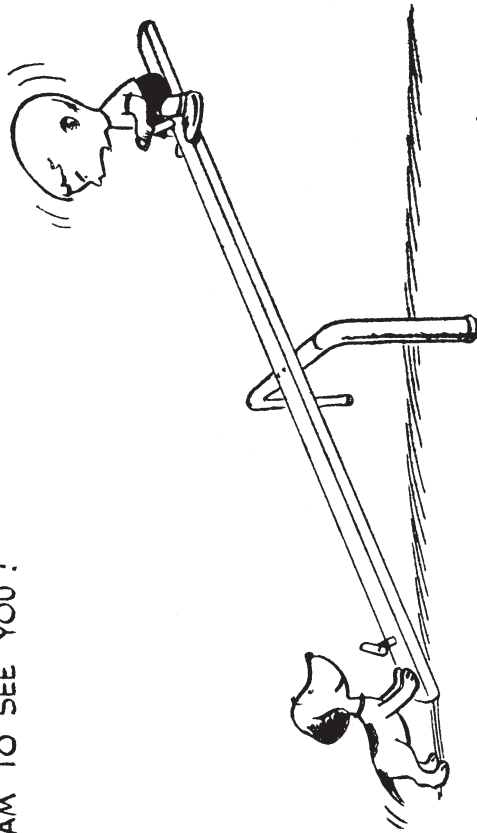

"ALL RIGHT, YOU'VE HAD YOUR FUN!....
NOW LET ME DOWN!"

Lil' Folks

BY SPARKY

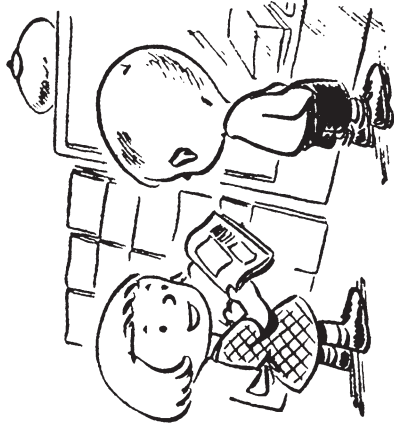
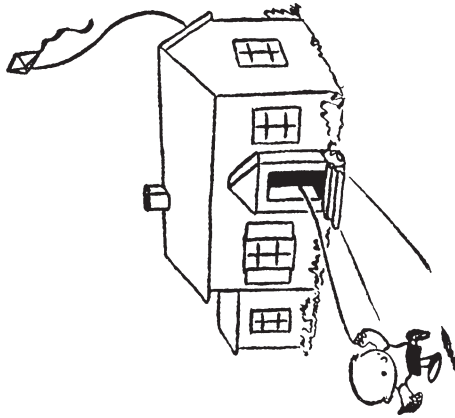

" HERE'S A SWELL
MAGAZINE... WHY DON'T
YOU BUY IT?... THEN
I'LL BORROW IT! "

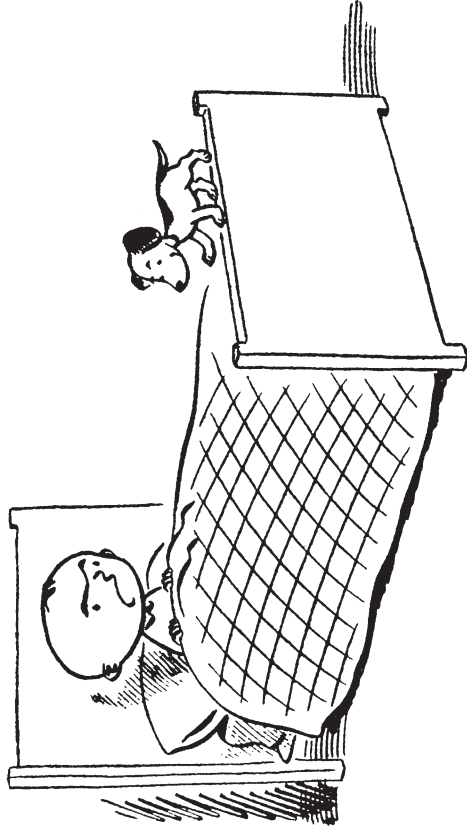

" ALL RIGHT, LET'S BREAK IT UP, AND GO TO BED! "

Lil'Folks

BY SPARKY

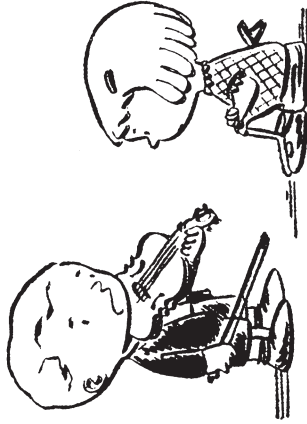

"I HOPE BEETHOVEN
DOESN'T TAKE THIS
TOO HARD..."

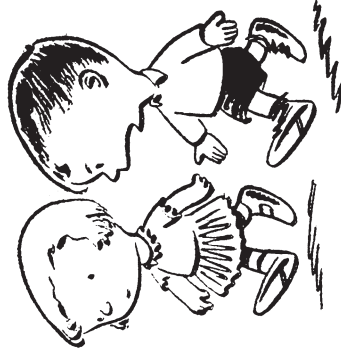

"BUT THE EARTH MUST
BE GETTING SMALLER
EVERY DAY WITH
MILLIONS OF PEOPLE
WALKING ALL OVER IT,
AND WEARING IT DOWN!"

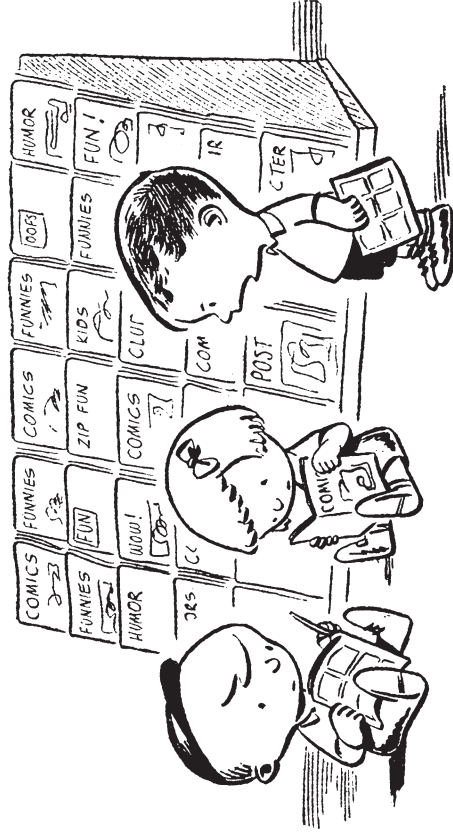

"IF THIS DRUGGIST WAS ANY KIND OF A
GUY, HE'D PUT IN BENCHES!"

Lil' Folks

BY SPARKY

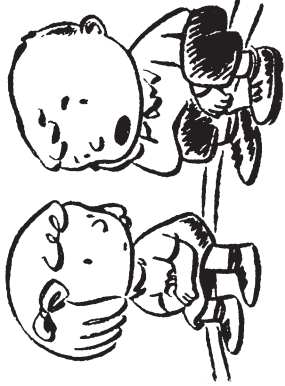
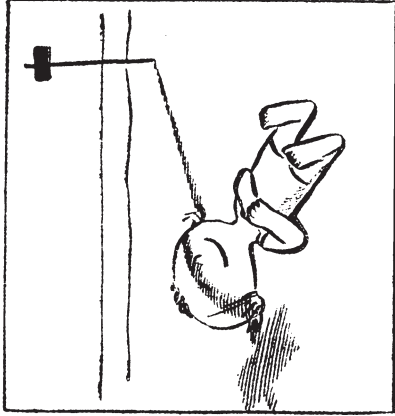

"IF SOMETHING EXCITING DOESN'T HAPPEN TO ME PRETTY SOON, I'M GOING TO HAVE AN AWFULLY BORING AUTOBIOGRAPHY."

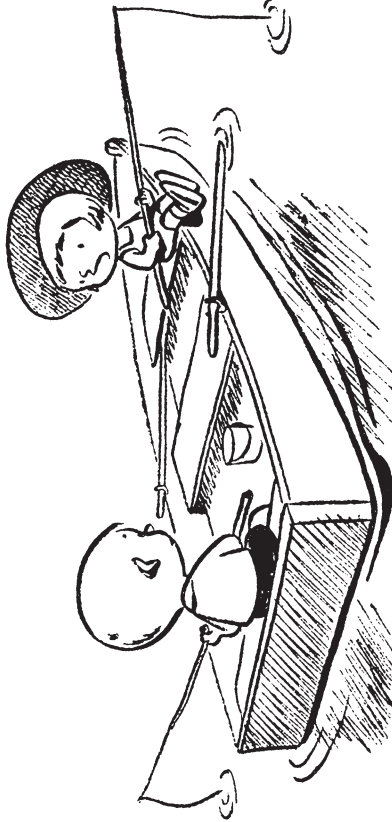

"AS SOON AS I CATCH THE LIMIT, I'LL QUIT, AND GIVE YOU A CHANCE!"

Lil' Folks

BY SPARKY

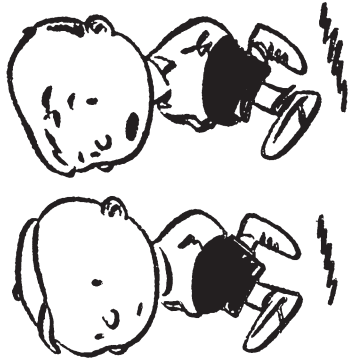
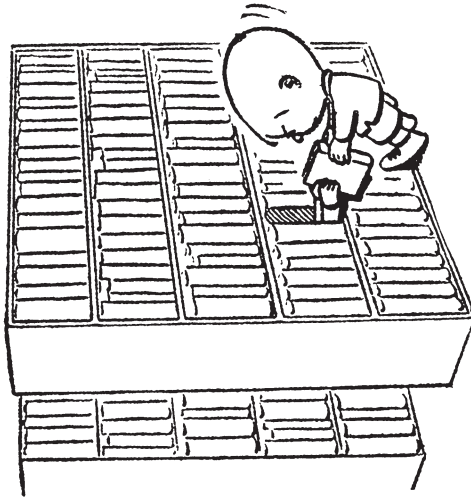

" I WONDER IF
I'LL HAVE AS MUCH
TROUBLE WITH
WOMEN AS I NOW
HAVE WITH GIRLS."

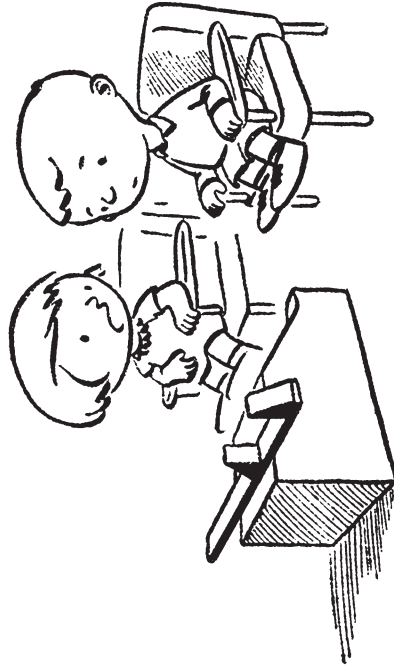

"DON'T WORRY, IF IT TURNS OUT TO BE SOME EIGHT-
EENTH CENTURY INSTRUMENT OF TORTURE, I'LL RUN FOR HELP!"

Lil' Folks

BY SPARKY

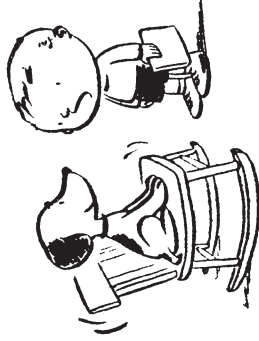

"IF YOU REALLY WERE
MAN'S BEST FRIEND,
YOU'D GET UP, AND
LET ME SIT THERE."

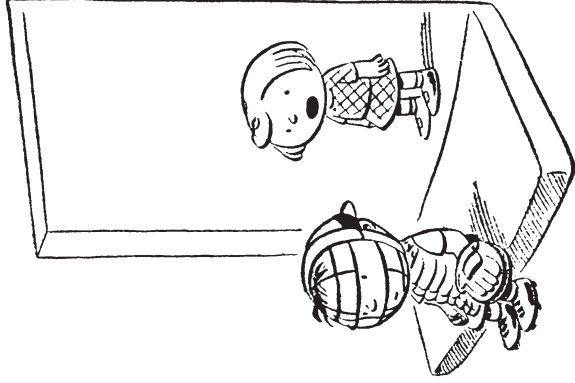

"WHY DON'T YOU RELAX?
THE GAME DOESN'T START
UNTIL THIS AFTERNOON!"

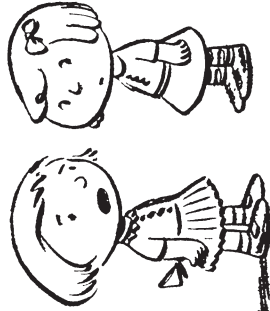

"THERE HE GOES...OUT OF MY LIFE FOREVER....I'LL
PROBABLY MISS HIM A LOT AT FIRST, BUT BY
THREE O'CLOCK I SHOULD BE OVER IT!"

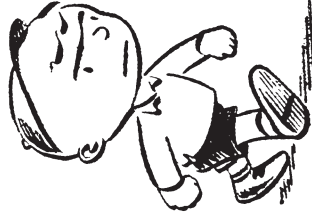

L'il Folks

BY SPARKY

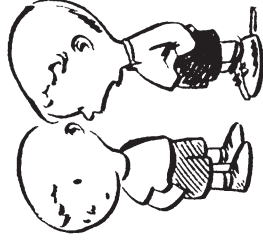

" HERE COMES GOOD
OLD CHARLIE BROWN!
HOW I HATE HIM!!"

" YOU'RE THE ONLY
PERSON I KNOW WHO
PLAYS SOLITAIRE WITH
A MARKED DECK!"

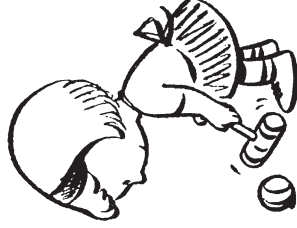
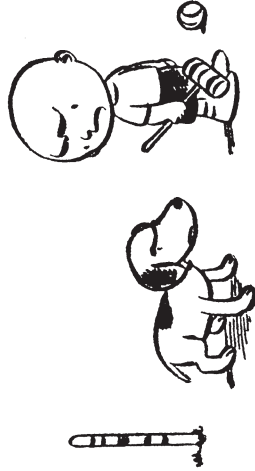

" TRY TO BE MORE PATIENT....IF WE'RE SHORT
OF HOOPS, WE'RE SHORT OF HOOPS!"

Lil' Folks

BY SPARKY

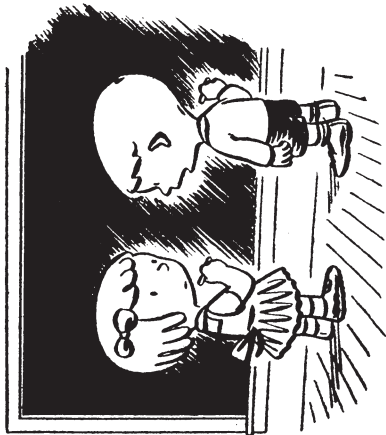

"I FIND IT HARD TO
CONCENTRATE IN SUCH
TURBULENT TIMES..."

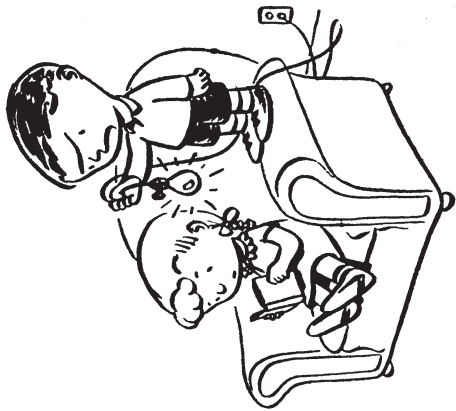

"YOU CAN'T POSSIBLY REALIZE
HOW GLAD I'LL BE WHEN WE
GET THAT NEW LAMP!"

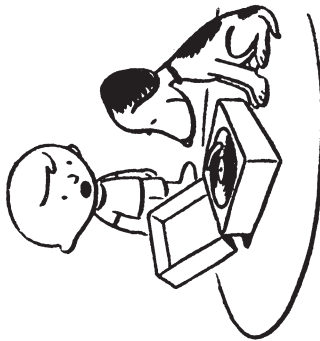
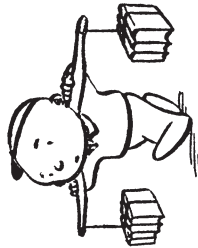
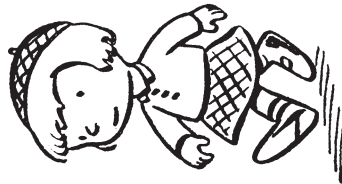

"IT WOULD SERVE YOU
RIGHT IF BEETHOVEN
DROVE ME CRAZY!"

Lil' Folks

BY SPARKY

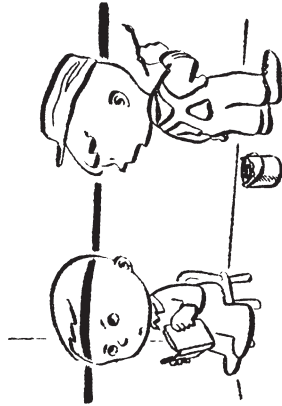

"OH, I'M SORRY.. YOU SHOULD HAVE SAID SOMETHING!"

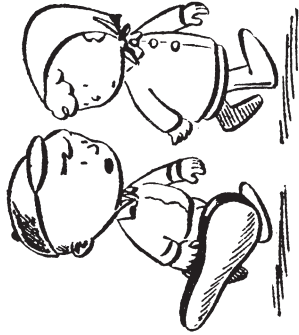

" MOZART AND I HAVE BEEN HAVING QUITE A TIME."

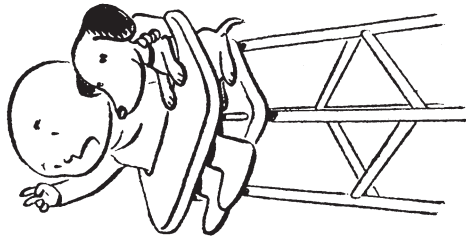

"MAKE THAT TWO GLASSES OF MILK.. I HAVE A GUEST."

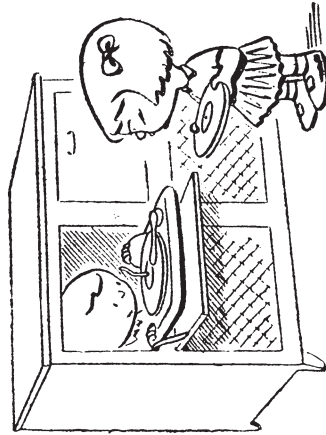

"SOMETIMES I WISH YOU WERENT SO INTERESTED IN THE MECHANICAL SIDE OF THINGS!"

Lil' Folks

BY SPARKY

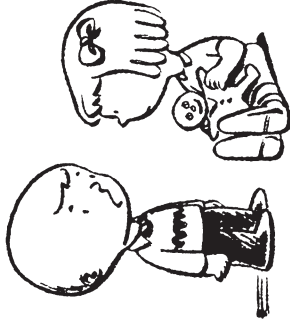

"WHAT DO REAL
MOMMAS AND POPPAS
DO WHEN THEY GET TIRED
OF PLAYING HOUSE?"

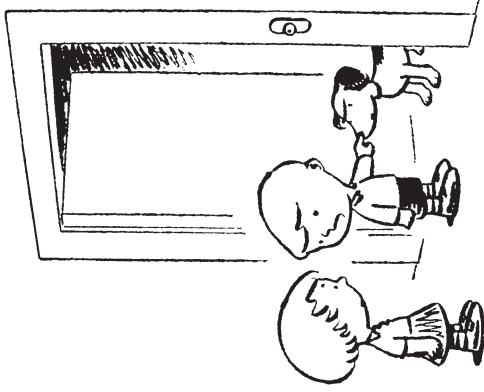

"STILL NO ANSWER
PROBABLY NO ONE HOME!"



"TEN MINUTES TO THREE?
ALL RIGHT, THANK YOU."

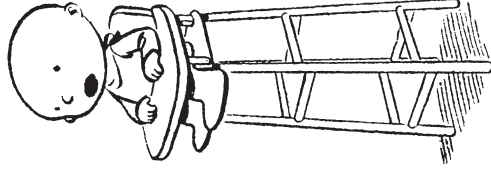

"MENU, PLEASE!"

Lil'Folks

BY SPARKY

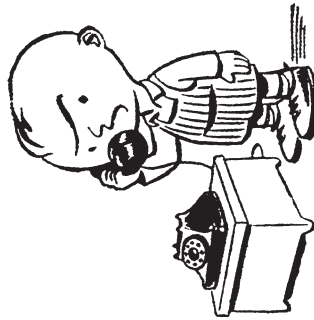

"WHAT DO YOU MEAN,
'IS THE HEAD OF THE
HOUSEHOLD IN?... WHO
DO YOU THINK I AM?"

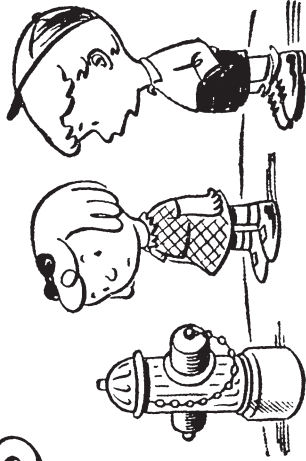

"I'M ALWAYS AMAZED AT HOW
THEY MANAGE TO GET SO
MUCH WATER OUT OF SUCH
A SMALL OBJECT!"

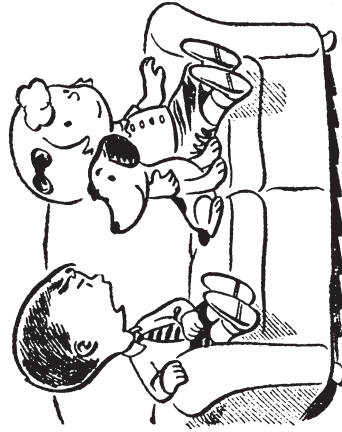

"MAN'S BEST FRIEND!...
THAT'S A LAUGH!!"

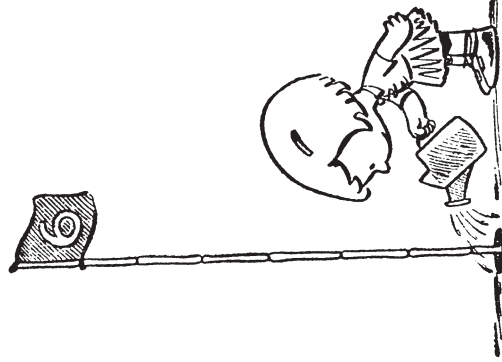

Lil' Folks

BY SPARKY

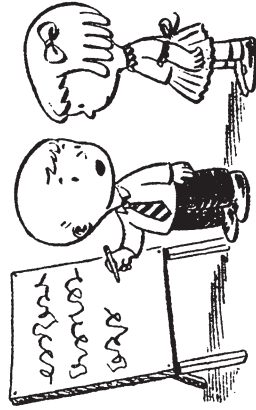

"HOW MANY 'E'S'
IN 'ELIZABETH'?"

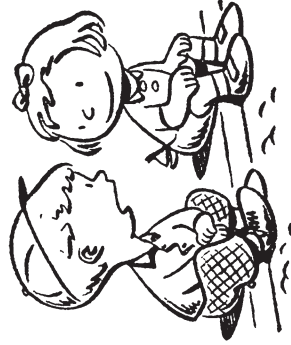

"I DON'T UNDERSTAND....
RIGHT NOW YOU FRIGHTEN
ME... TEN YEARS FROM
NOW YOU'LL PROBABLY
FASCINATE ME!"

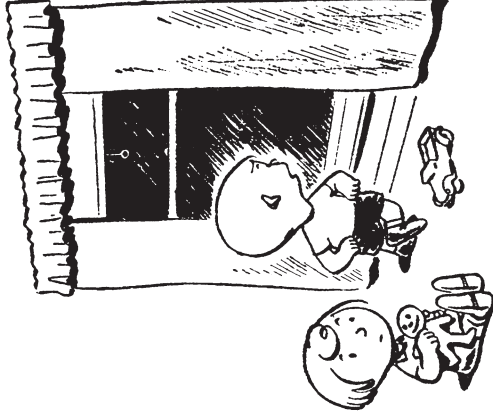

"I'VE BEEN NOTICING
LATELY THAT EVERYTIME
THE SUN GOES DOWN IT
GETS DARK OUTSIDE!"

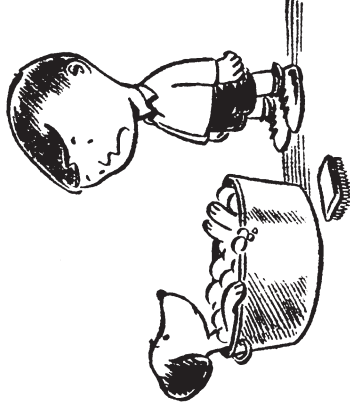

"DO YOU WANT ME TO
SCRUB YOUR BACK?"

Lil' Folks

BY SPARKY

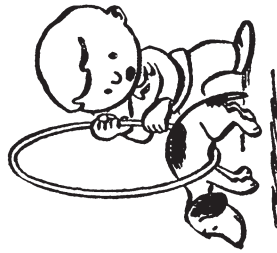

"NICE TRY!"

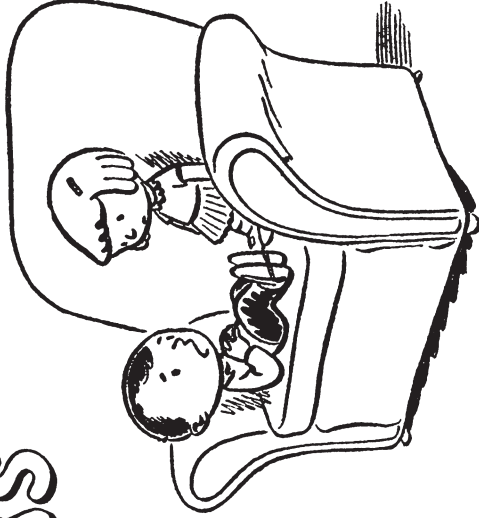

"AFTER YOU GET TO BE AS OLD AS I AM, YOU'LL SEE THINGS IN A DIFFERENT LIGHT."

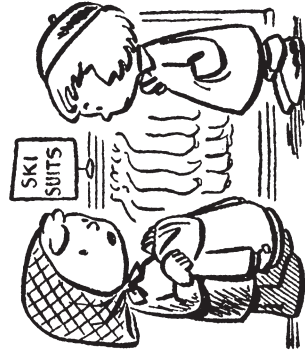

"WHAT COLOR DO YOU SUPPOSE WOULD GO WELL WITH AN OVERCAST SKY?"

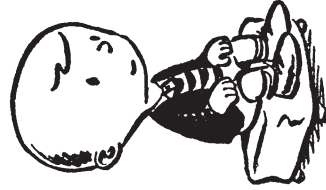

"IF I HAD KNOWN THAT YOU WERE COMING, I'D HAVE BAKED A MUD-PIE!"

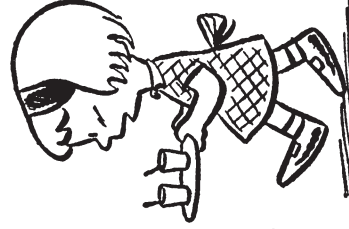

Lil' Folks

BY SPARKY



"DOES MAN'S BEST
FRIEND HAVE ANY LOVE
TO SPARE FOR A VERY
LONESOME YOUNG LADY?"

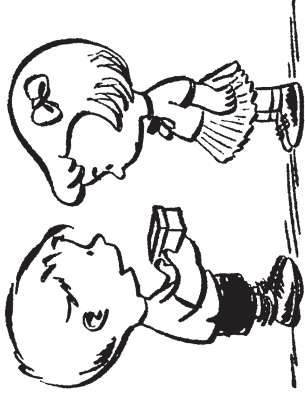

"I'M TRYING TO
SAVE UP ENOUGH
MONEY TO BUY A
PIGGY BANK!"

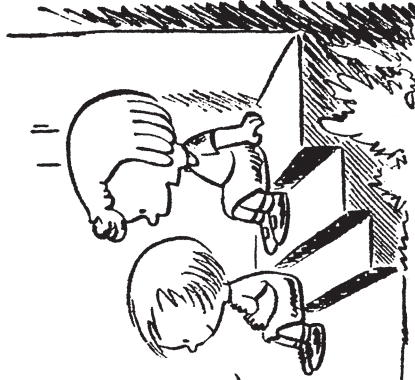
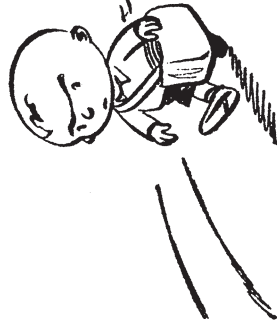

"I LIKE TO SEE A YOUNG MAN WORKING....IT'S A SIGN
THAT HE'S AMBITIOUS, AND THEREFORE WILL
SOMEDAY MAKE A GOOD HUSBAND!"

Lil' Folks

BY SPARKY

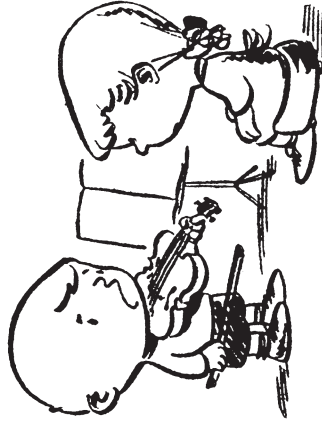
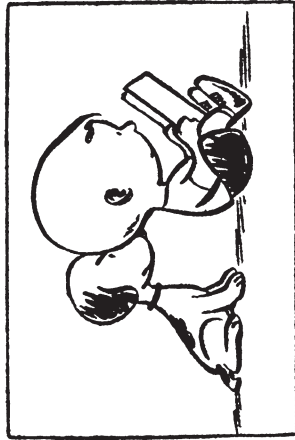

"I DREAD THE DAY
WHEN I HAVE TO MEET
BEETHOVEN FACE TO FACE."



"BROWN? WHY, NO.... WHAT MAKES YOU
THINK I'VE SEEN CHARLIE BROWN?"

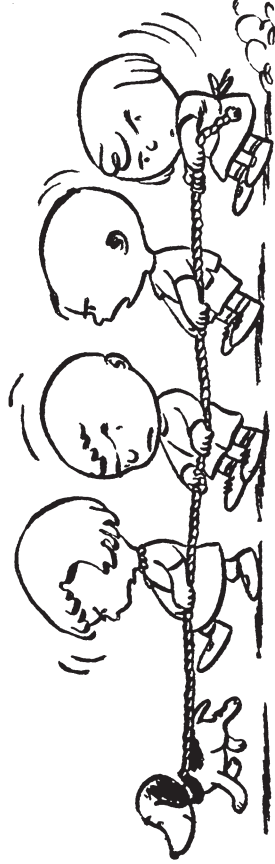

Lil' Folks

BY SPARKY

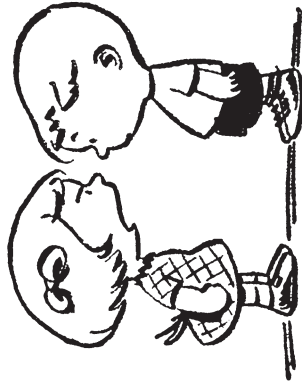

"YOU'D BETTER TREAT ME WITH MORE RESPECT.... SOMEDAY I MAY BE SOMEBODY'S MOTHER!"

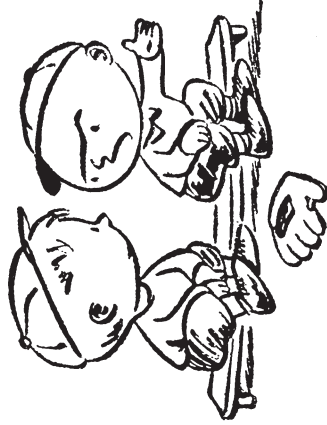

"OF COURSE WE'RE PROUD OF GRANDMA.... DOESN'T SHE LEAD THE LEAGUE IN STOLEN BASES?!"

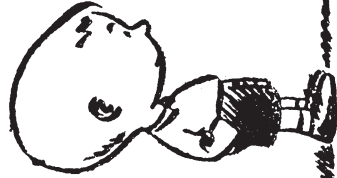

"WHY CAN'T HE FACE THE FACTS ? IF THERE'S NO TOWEL, THERE'S NO TOWEL !!"

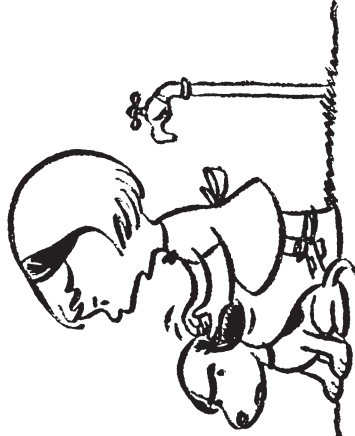

L'il Folks

BY SPARKY

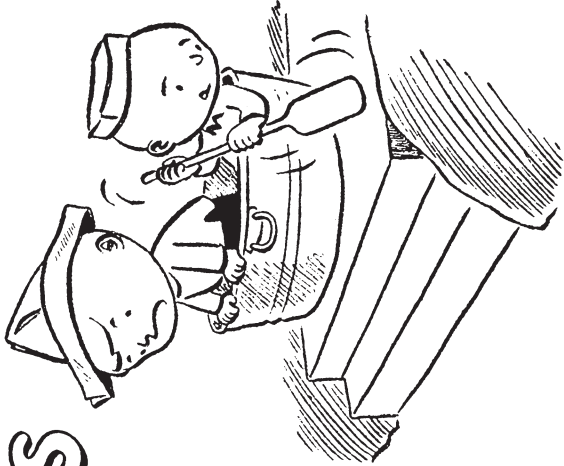
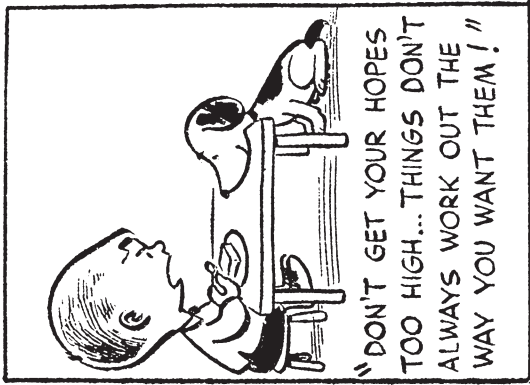

"GOOD GRIEF! PADDLE LIKE MAD... WE'RE BEING SWEPT OVER THE FALLS!"

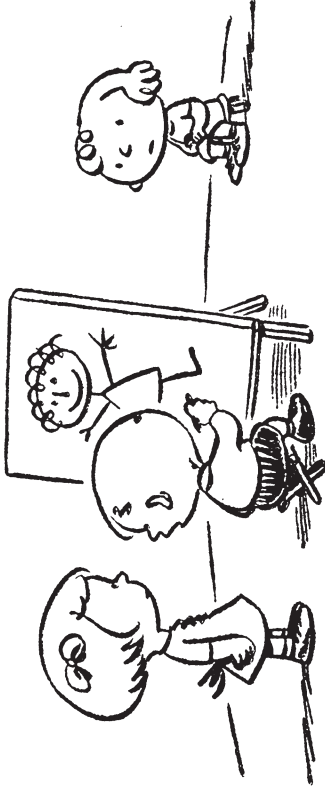

"DON'T WORRY, YOU'LL KNOW IT'S HER WHEN I PUT HER NAME ON THE BOTTOM!"

Lil' Folks

BY SPARKY

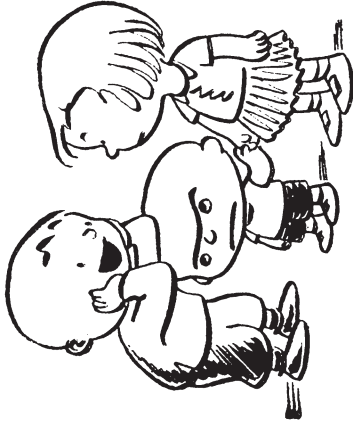

"HELLO THERE, CUTIE...
HOW ABOUT YOU AND
ME STEPPING OUT?"

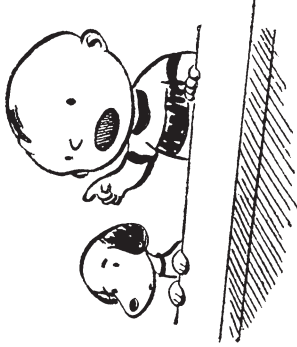

"ONE BOTTLE OF
STRAWBERRY, PLEASE
AND KINDLY IGNORE
ANY SIGHS WHICH
YOU MAY HEAR!"

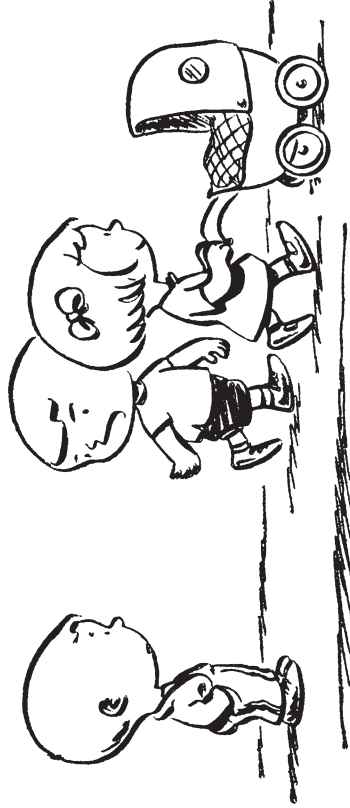

"THIS IS WHAT I DON'T LIKE ABOUT PLAYING HOUSE...."
SOMETIMES YOU GET DANGEROUSLY CLOSE TO REALISM!"

Lil' Folks

BY SPARKY

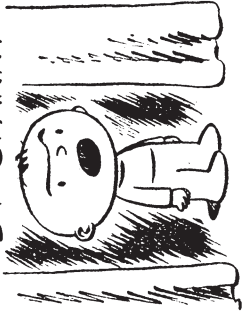

"HOW OLD DO I HAVE TO BE BEFORE I CAN STAY UP LATE ENOUGH TO BE TOO TIRED TO GET UP IN THE MORNING?"

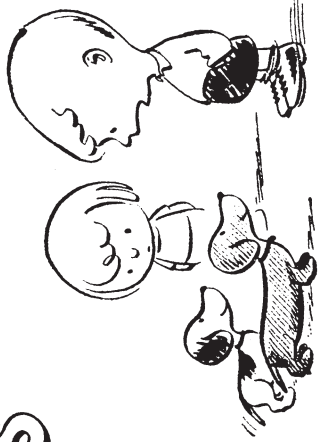

"IT'S DIFFICULT TO SAY WHICH YOU PREFER WITHOUT SHOWING RACIAL PREJUDICE!"

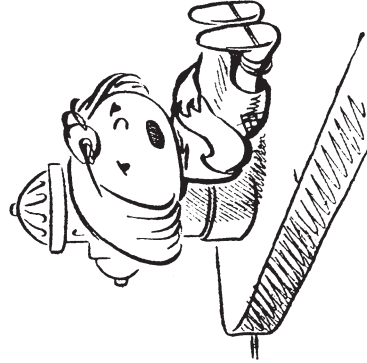

"FORTUNATELY, REAL BEAUTY IS SOMETHING THAT LIES WITHIN!"

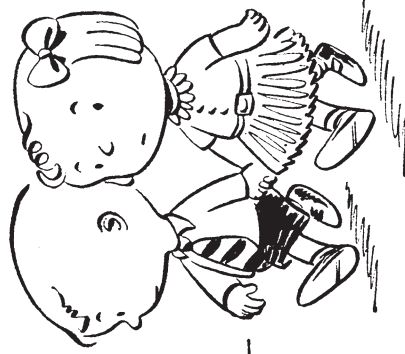

Lil' Folks

BY SPARKY



"MY BUDDY AND I LIKE TO THINK OF OURSELVES AS BEING SUCCESSFUL PRODUCTS OF THIS NEW POST-WAR WORLD!"

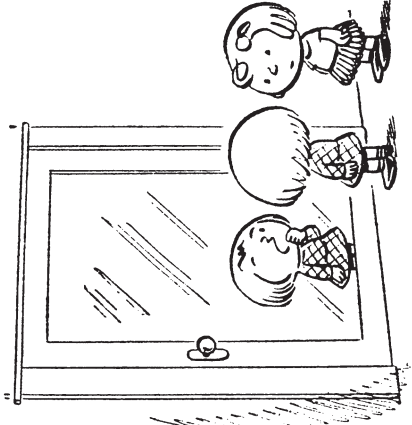

"I HATE THE THOUGHT THAT HALF OF MY LIFE PROBABLY WILL BE SPENT IN FRONT OF A MIRROR!"

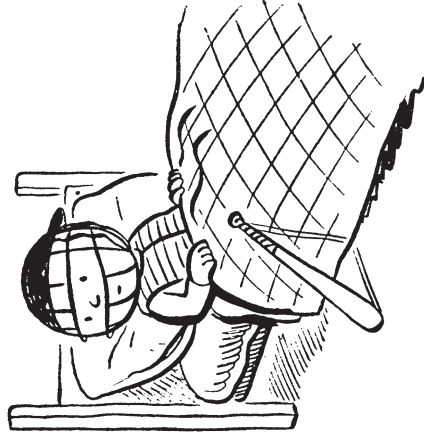
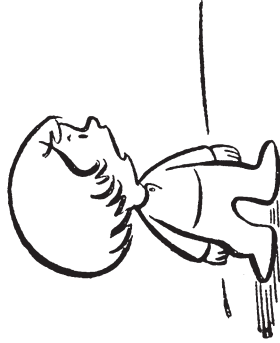

"AM I RIGHT IN ASSUMING THAT TOMORROW IS THE DAY OF THE BIG GAME?"

Lil'Folks

BY SPARKY

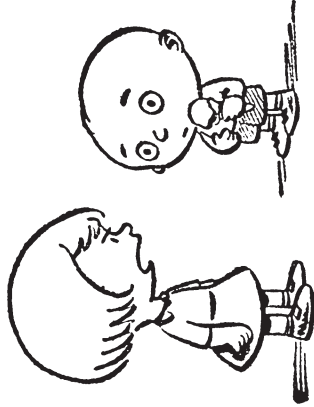

"THE TROUBLE WITH YOU IS THAT YOUR EYES ARE BIGGER THAN YOUR STOMACH!"

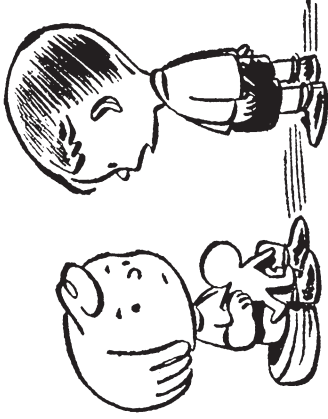

"I'VE BEEN WAITING ALL DAY TO TELL YOU SOMETHING VERY IMPORTANT, BUT I'VE FORGOTTEN WHAT IT WAS."

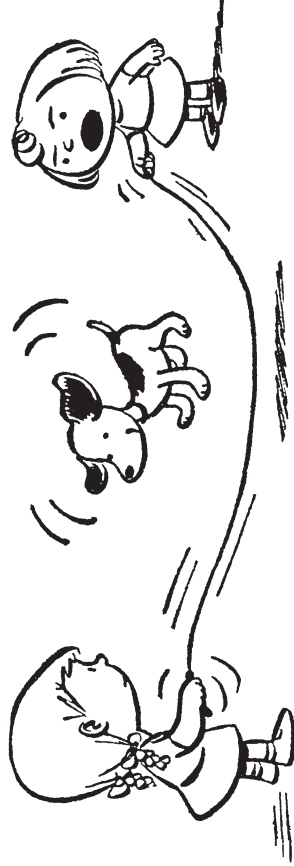

"ONE HUNDRED AND ONE, ONE HUNDRED AND TWO... YOU REALIZE, OF COURSE, THAT HE'S MAKING FOOLS OUT OF BOTH OF US!"

Lil' Folks

BY SPARKY

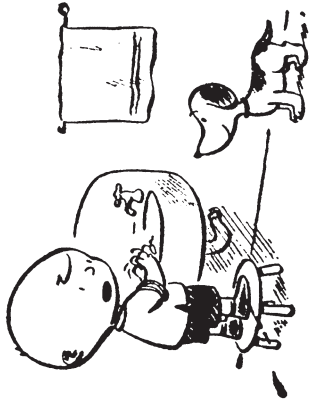

"I SUPPOSE THERE'S NOT MUCH SENSE IN YOU WASHING YOUR HANDS IF YOU'VE GOT TO WALK ON 'EM RIGHT AWAY AGAIN!"

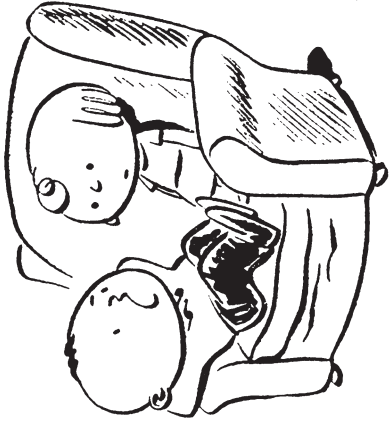

"WHEN YOU GET TO BE MY AGE, YOU FEEL THAT THE WORLD IS SORT OF CLOSING IN ON YOU..."

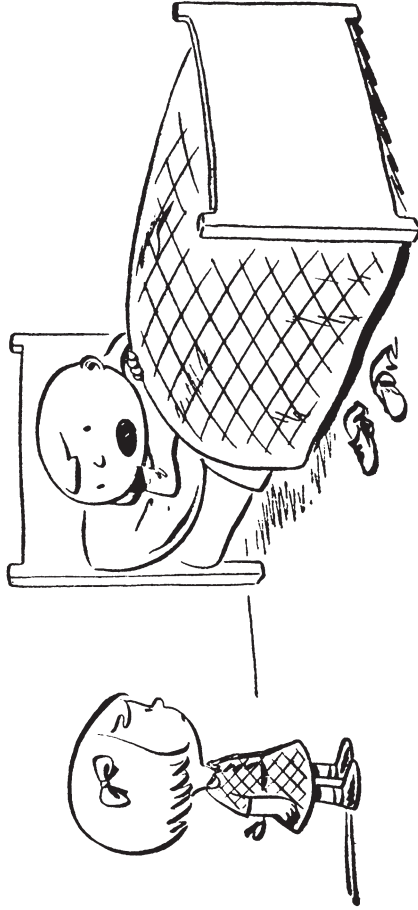

"WHEN YOU GO BACK DOWNSTAIRS, ASK MOM WHAT THE ODDS WOULD BE ON 'MY FINISHING SCHOOL BY CORRESPONDENCE!'"

L'il Folks

BY SPARKY

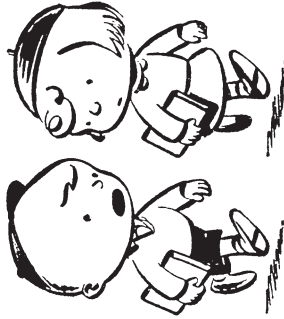

"I THINK THAT I'M BEING
STIFLED BY SOME IMPERCEPTIBLE
FLAW IN OUR EDUCATIONAL
SYSTEM!"

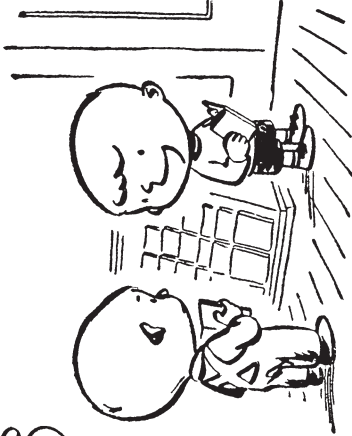

"LET'S BUY THIS
ONE... I FOUND A
BAD WORD IN IT!"

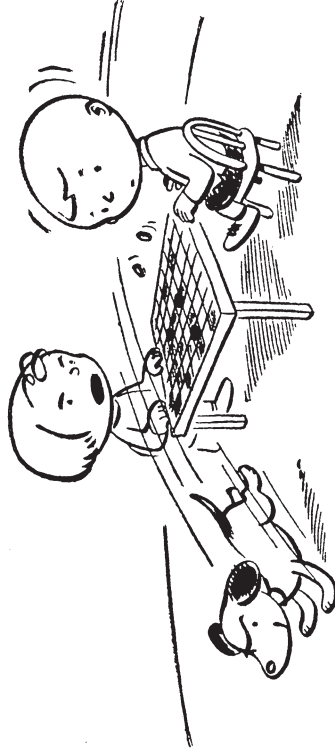

"IT'S ALMOST SADISTIC THE WAY HE
DOES THAT !!"

Lil' Folks

BY SPARKY

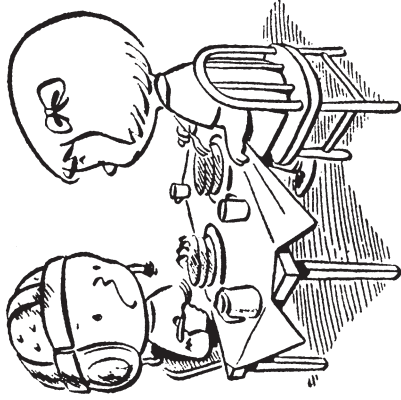
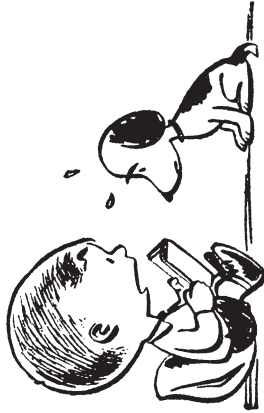

" IF ALBERT PAYSON
TERHUNE IS GOING TO
AFFECT YOU THIS WAY,
WE'D BETTER READ
SOMETHING ELSE ! "

" DO YOU THINK MOM WOULD BE
INSULTED IF I SAVED A
COUPLE OF THESE PANCAKES
FOR SHOULDER-PADS ? "

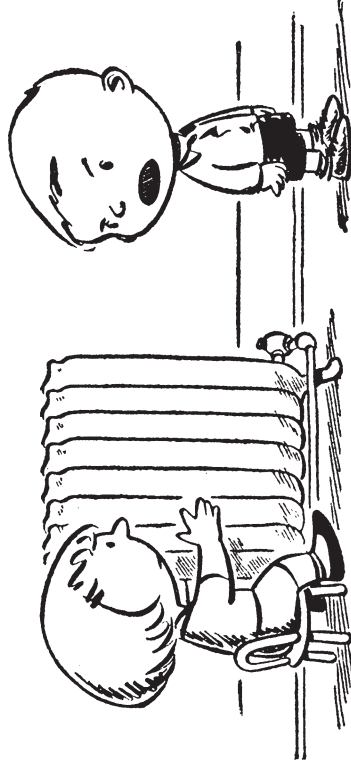

" THEN AGAIN IF YOU EVER DID GET A REAL
HARP, YOU'D PROBABLY DRIVE US ALL CRAZY WITH IT. "

Lil' Folks

BY SPARKY

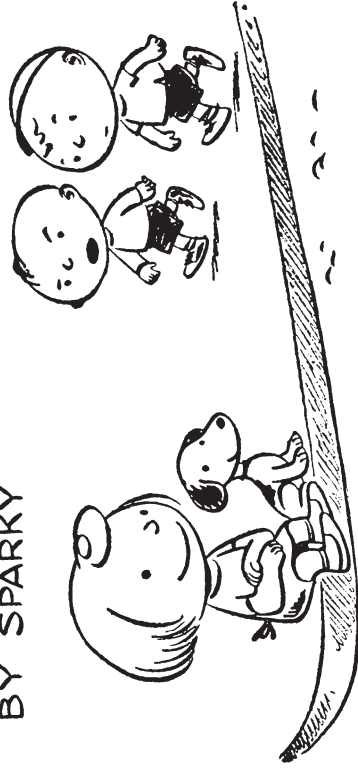

"THERE SITS A STRANGE COMBINATION...A DOG AND A GIRL....MAN'S BEST FRIEND AND MAN'S BIGGEST PROBLEM!"

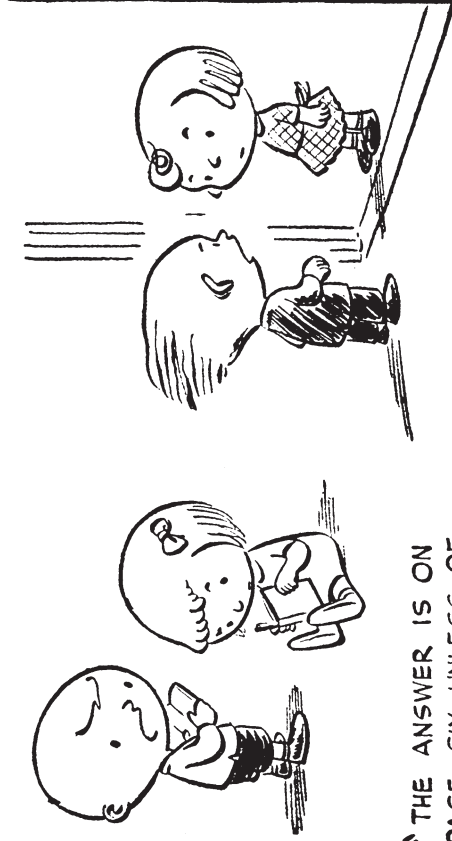

"THE ANSWER IS ON PAGE SIX UNLESS, OF COURSE, YOU'RE HOLDING THE BOOK UPSIDE DOWN!"

"SORRY I'M LATE... I RAN ALL THE WAY!"

Lil' Folks

BY SPARKY

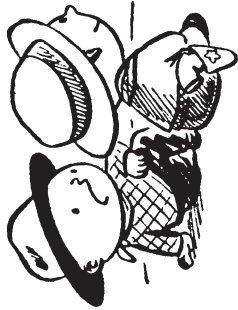
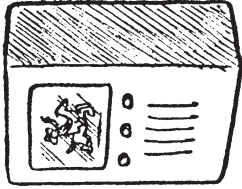
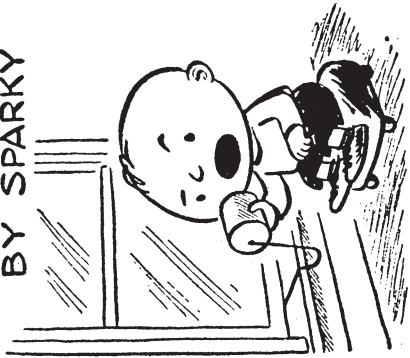

REMEMBER, WE'LL HAVE ONLY
THREE MINUTES TO CHANGE
OUTFITS BEFORE THE NEXT
PROGRAM BEGINS ! "

" TESTING ONE,
TWO WHAT COMES
AFTER TWO ? "

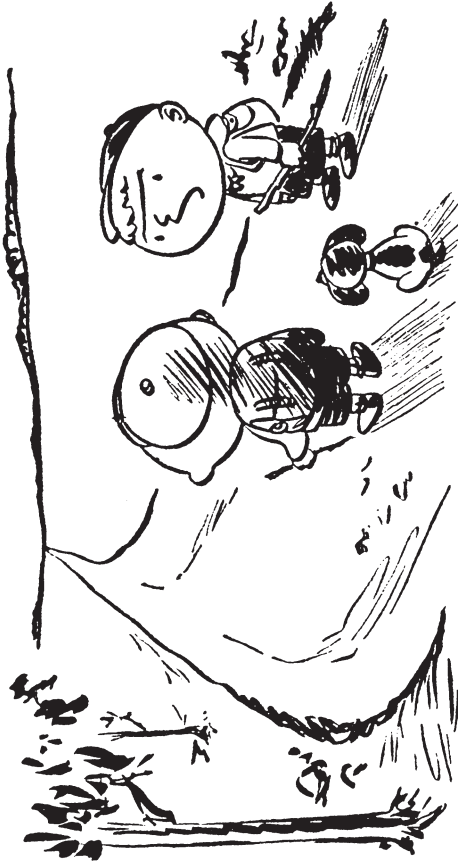

" WE WON'T GET ANYPLACE ON THIS ROAD....IT COMES TO A POINT ! "

L'il Folks

BY SPARKY

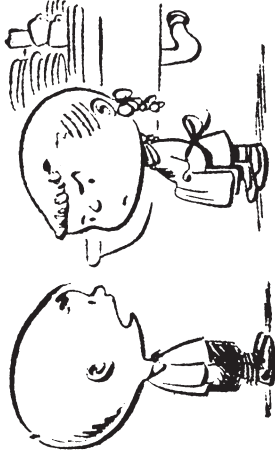

"LET'S PLAY HOUSE...
YOU WASH THE DISHES...
WHILE I RELAX IN THE
LIVING ROOM ALL WEARY
FROM A DAY'S WORK!"

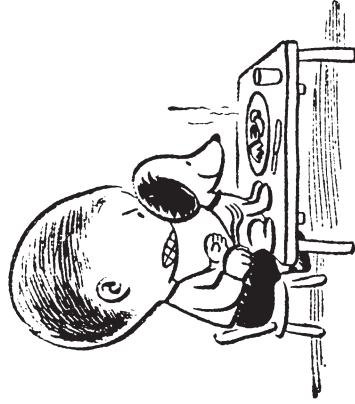

"YOU DON'T KNOW HOW CLOSE
YOU ARE TO BEING EATEN!"

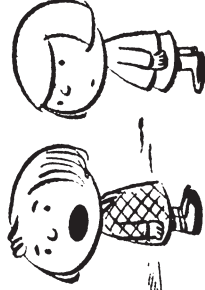
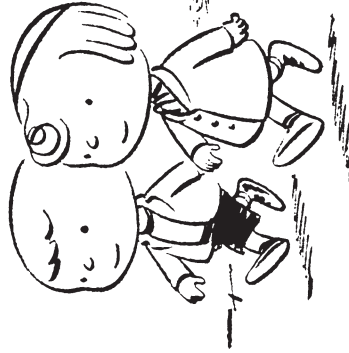

"I ONCE HAD TWO BOY FRIENDS, BUT I PLAYED ONE
AGAINST THE OTHER UNTIL I LOST THEM BOTH!"

Lil' Folks

BY SPARKY

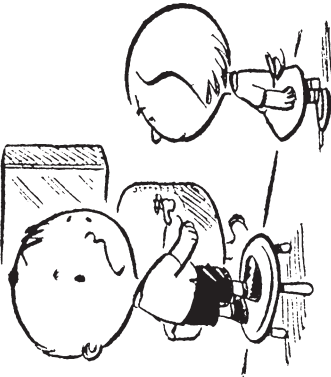

"IT TURNED OUT TO BE ONLY
DIRT, BUT FOR ONE BRIEF
EXCITING MOMENT I THOUGHT
I NEEDED A SHAVE !!"



"NO FANCY RIDING NOW,
PLEASE IF ANYTHING
HAPPENED TO YOU, I DON'T
KNOW WHAT I'D DO..."

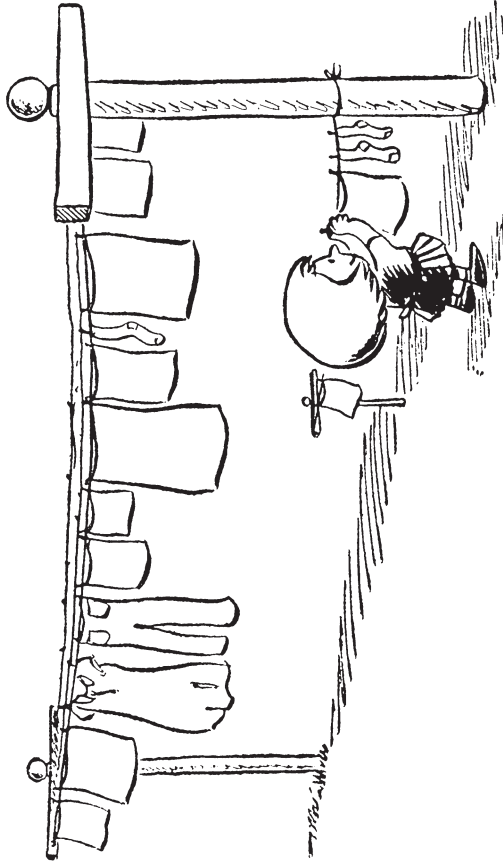

Lil' Folks

BY SPARKY

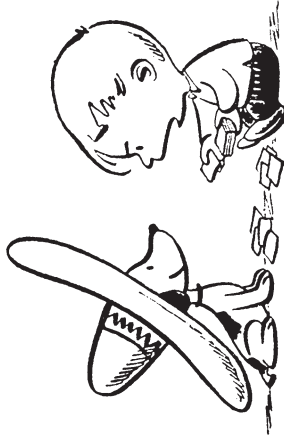

"YOU KNOW IT REALLY ISN'T NECESSARY TO WEAR A HAT LIKE THAT TO PLAY 'CANASTA'!"

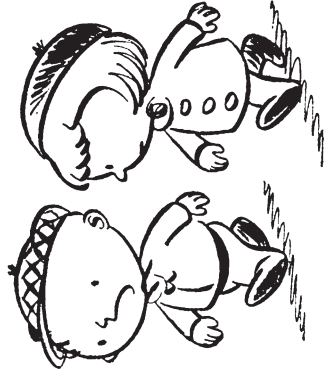

"THE TROUBLE WITH OUR GENERATION IS THAT WE'RE ALL TOO YOUNG!"

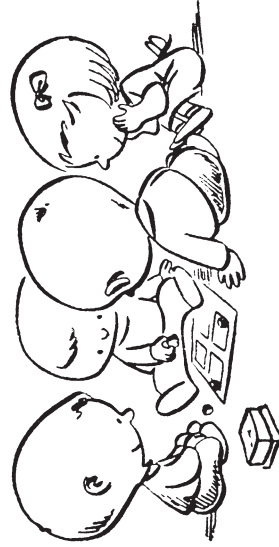
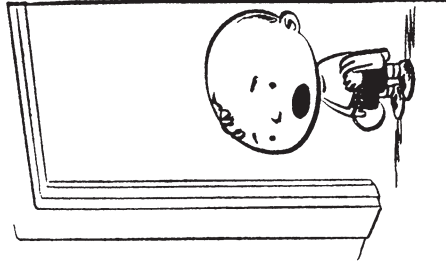

"SO I GUESS I'LL HAVE TO BE GOING... I SAID I HATE TO SPOIL ALL THE FUN, BUT I GUESS I'LL HAVE TO BE GOING!"

Lil' Folks

BY SPARKY



"HMM... MAYBE I WAS
WRONG.... IN YOUR CASE
EAR-RINGS DO SEEM
RATHER NEEDLESS!"



"YOU CERTAINLY LOOK
SWELL IN BLACK!"

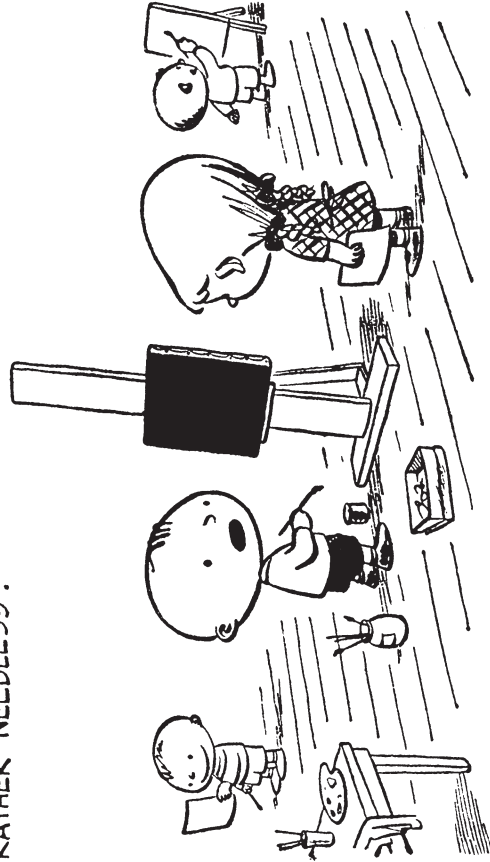

"WHAT I'M STRIVING FOR IS A REAL
FEELING OF DARKNESS!"

Lil' Folks

BY SPARKY

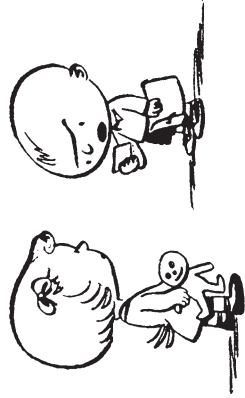

"HOW DO YOU LIKE THAT!?
ANOTHER REJECTION SLIP
FROM THE 'CHILDREN'S BED-
TIME STORIES' MAGAZINE!"

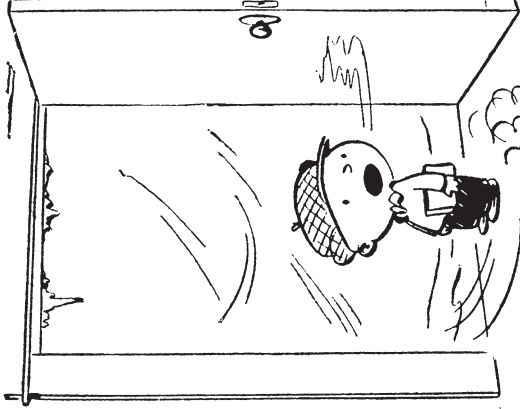

"I'LL NEVER MAKE IT TO
SCHOOL THROUGH THIS BLIZZARD,
BUT I'M SURE I COULD FIGHT
MY WAY DOWN TO THE MOVIE!"

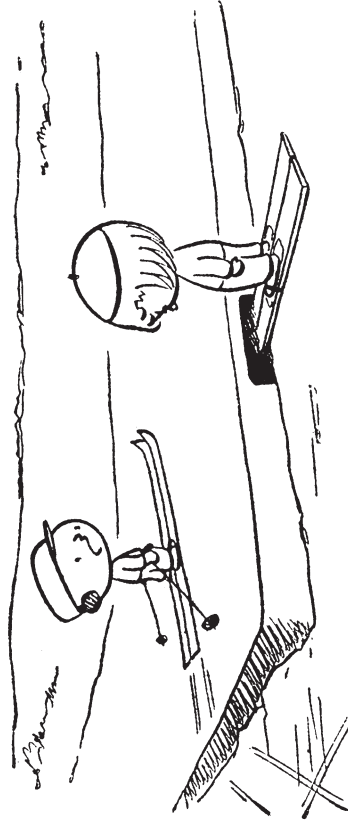

"DON'T BECOME DISCOURAGED... WHEN WE GET OUT IN
THE COUNTRY, THE GOING WILL BE MUCH EASIER!"

Lil' Folks

BY SPARKY

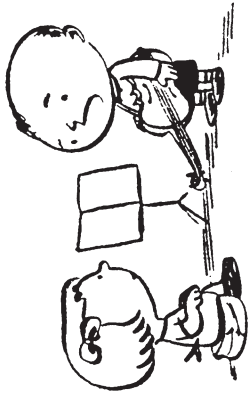
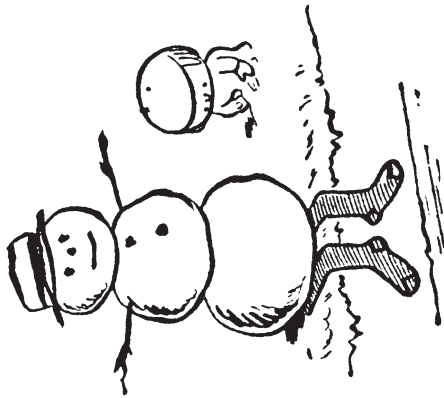

"THERE'S ONE THING ABOUT BEETHOVEN THAT CONFUSES ME.....HIS MUSIC !!"

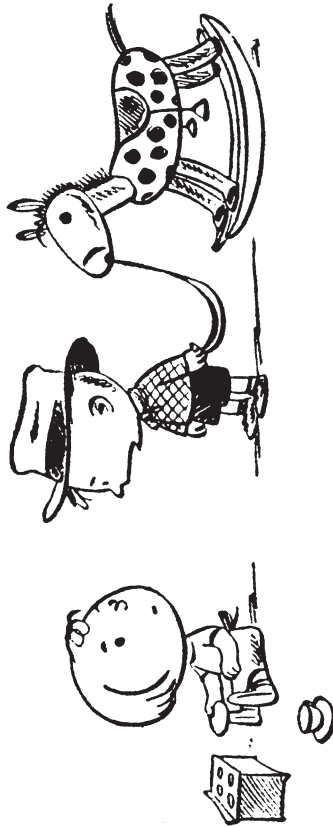

"COULD YOU SPARE A WEARY TRAVELER A BITE TO EAT, MA'AM? I'VE JUST RIDDEN IN ALL THE WAY FROM THE LIVING-ROOM !"

Lil' Folks

BY SPARKY

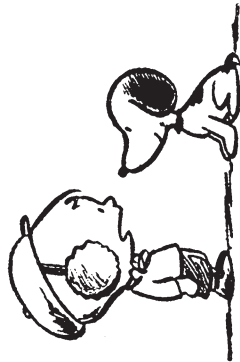
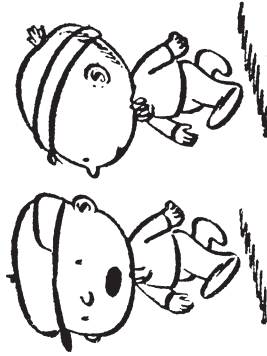

" I DISTINCTLY HEARD GRANDMA SAY THAT SHE'S GOING TO USE HER WHOLE PENSION CHECK THIS MONTH TO GET A NEW PAIR OF HOCKEY SKATES. "

" BUILT IN EAR-MUFFS, EH? THAT MUST BE RATHER CONVENIENT! "

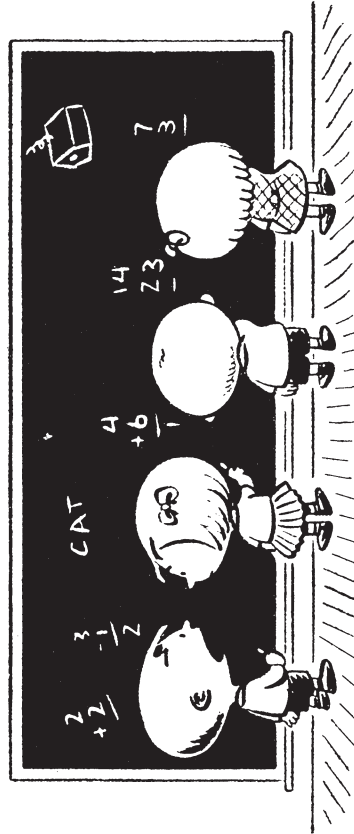

" SEVEN AND SIX MUST BE THIRTEEN.... I SAW IT ON THE SPORTS PAGE THIS MORNING! "

Lil' Folks

BY SPARKY

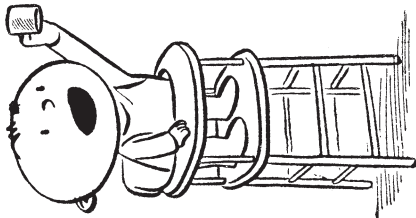
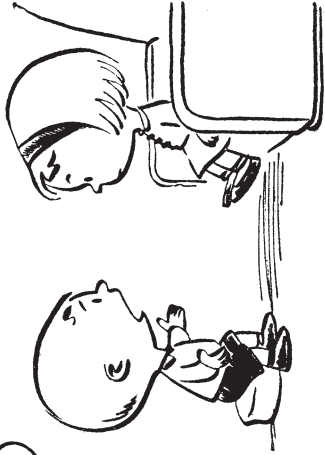

"A TOAST !!...."

"I AM ENTHRALLED BY YOUR GREAT BEAUTY, FASCINATED BY YOUR SPARKLING PERSONALITY, AND INTRIGUED BY YOUR AMAZING COLLECTION OF COMIC BOOKS!"

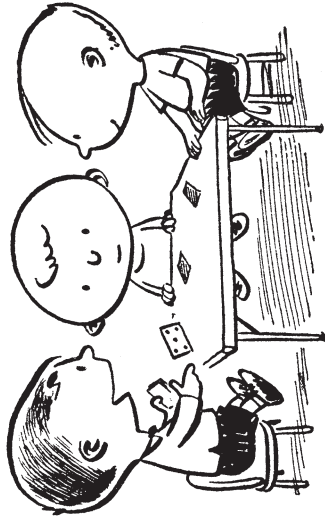
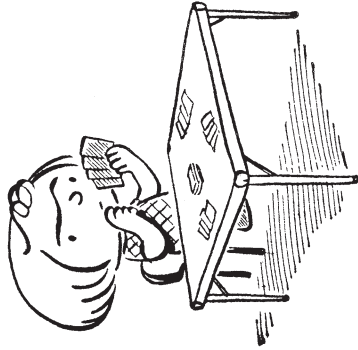

"SEE? WE CAN HAVE ANOTHER GAME ON THE SIDE WHILE SHE'S TRYING TO FIGURE OUT WHAT TO PLAY!"

Lil' Folks

BY SPARKY

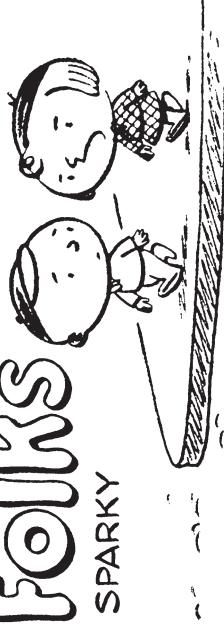

"I DREAMED ABOUT YOU LAST NIGHT ... GUESS I'M GOING TO HAVE TO QUIT EATING JUST BEFORE GOING TO BED!"

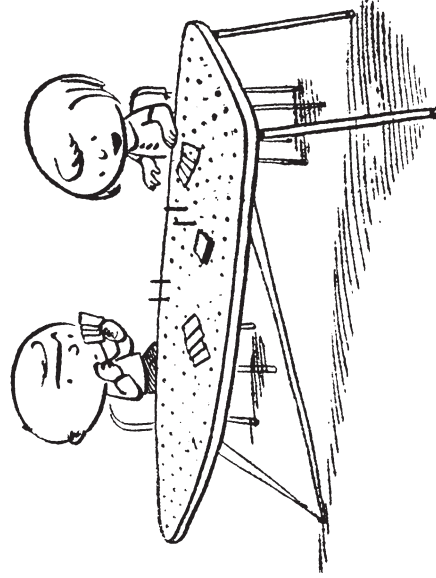
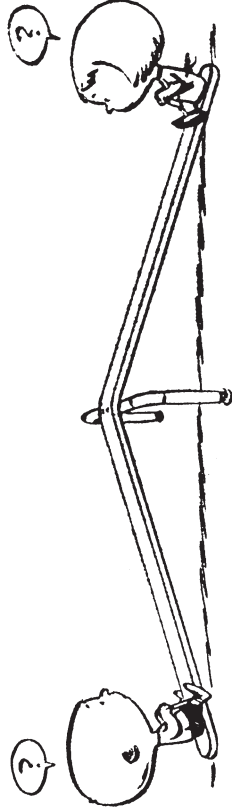

"FIFTEEN SIX, FIFTEEN EIGHT, AND THREE IS...."

Lil' Folks

BY SPARKY

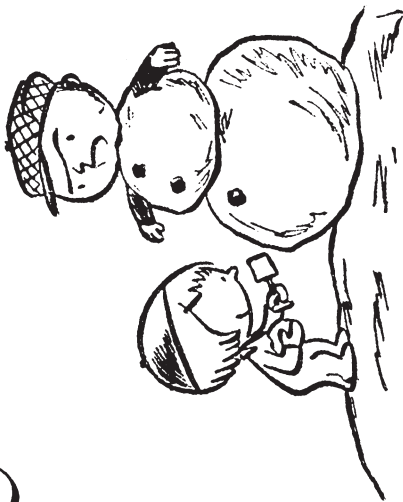
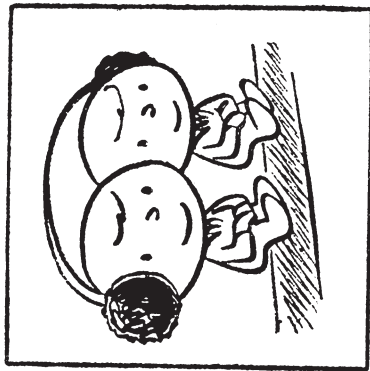

"I DON'T UNDERSTAND THIS
SUDDEN DESIRE FOR REALISM!"

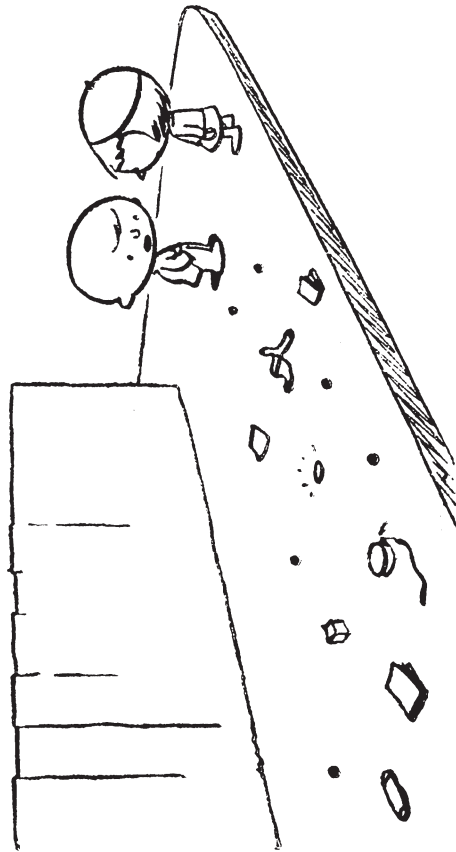

"WELL, WHAT DO Y'KNOW?..... I'VE GOT A
HOLE IN MY POCKET!!"

Lil'Folks

BY SPARKY



WHAT'S THE DATE TODAY ? "

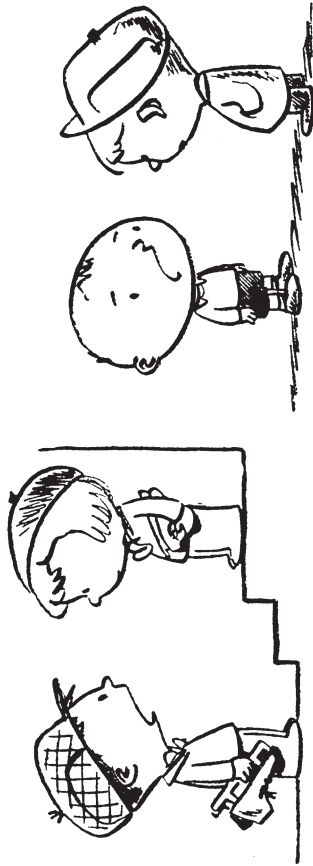

" BEING WITH YOU TODAY
HAS DONE ME A LOT OF
GOOD....IT'S MADE ME
FEEL YEARS YOUNGER! "

" I'D BE GLAD TO LOAN
YOU MY FLASHLIGHT, BUT
IT'S IN THE ATTIC, AND
IT'S SO DARK UP THERE
I CAN'T FIND IT ! "

Lil' Folks

BY SPARKY

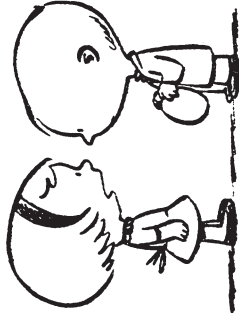

"ALL RIGHT, IT'S SETTLED THEN...AS SOON AS YOU FINISH COLLEGE, WE'LL BE MARRIED.... HOW LONG WILL IT BE BEFORE YOU BEGIN KINDERGARDEN?"

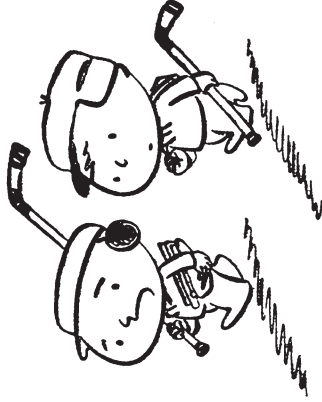

" I WISH GRANDMA WOULD HAVE MADE AT LEAST ONE GOAL... NOW SHE'LL BE CRABBY FOR THE REST OF THE WEEK!"

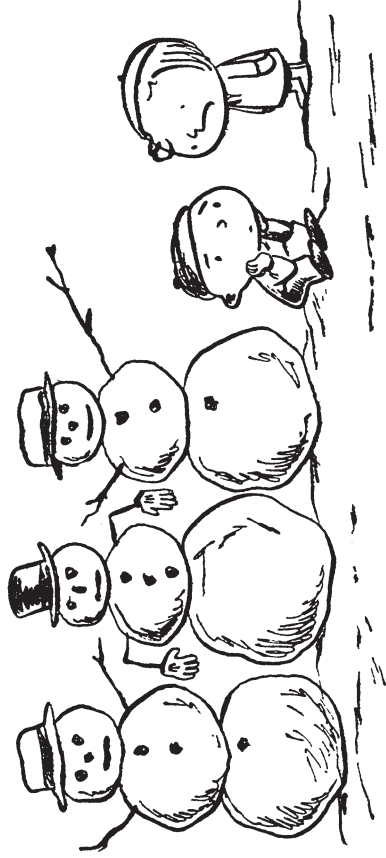

" DON'T GET DISCOURAGED.... LOTS OF SCULPTORS HAVE BEEN FAILURES WITH THEIR FIRST ONE-MAN SHOWS..."

Lil' Folks

BY SPARKY

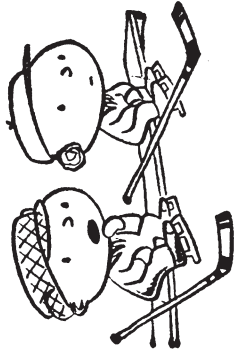

"WOW! THAT'S THE THIRD PENALTY THEY'VE GIVEN GRANDMA FOR UNNECESSARY ROUGHNESS!"

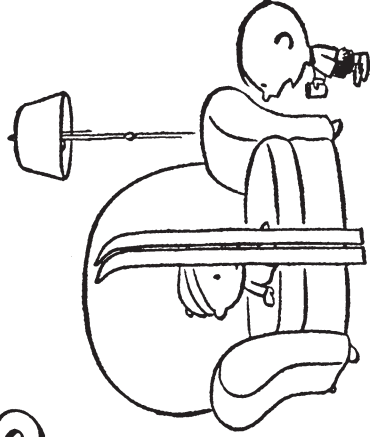

"JUST MAKE YOURSELF AT HOME... I'LL BE WITH YOU AS SOON AS I FINISH EATING."

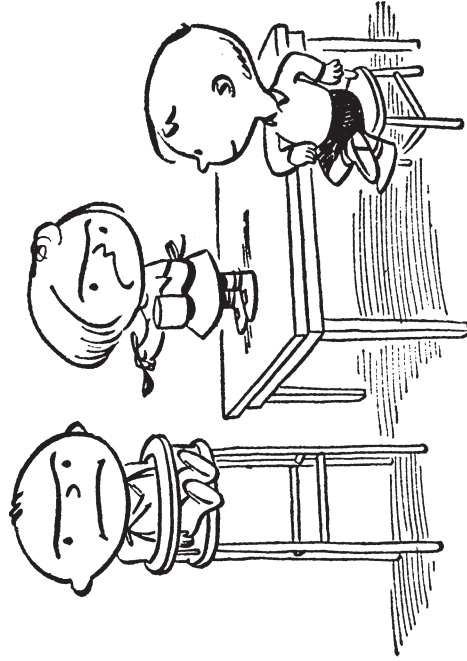

"STOP SAYING, 'THERE'S MANY A SLIP BETWEEN THE CUP AND THE LIP!'"

Lil' Folks

BY SPARKY

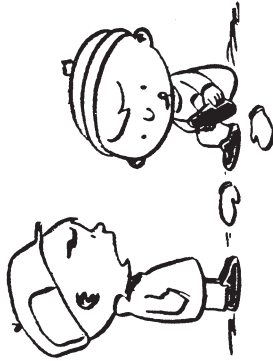

"RUBBERS ALWAYS LAST
ME TWICE AS LONG AS
THEY DO MOST PEOPLE
BECAUSE I FORGET TO WEAR
THEM HALF THE TIME!"

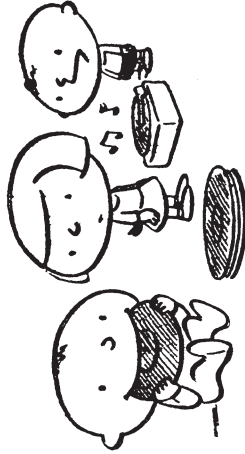

"DON'T WORRY...IT'S
NON-BREAKABLE!"

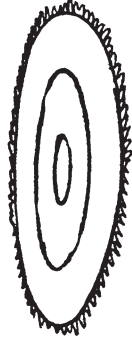
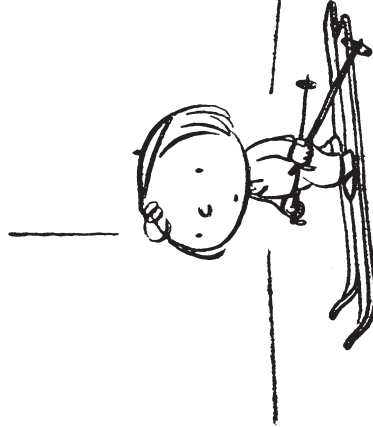
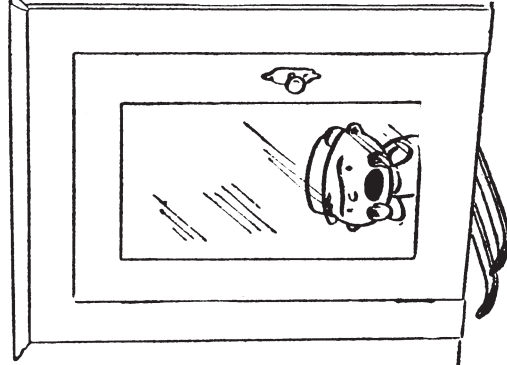

Lil' Folks

BY SPARKY

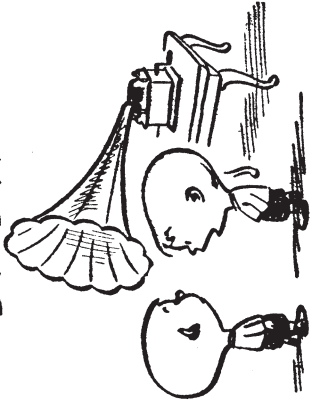

"GRANDMA IS ACTUALLY THINKING OF GETTING A LONG-PLAYING ATTACHMENT FOR IT!"

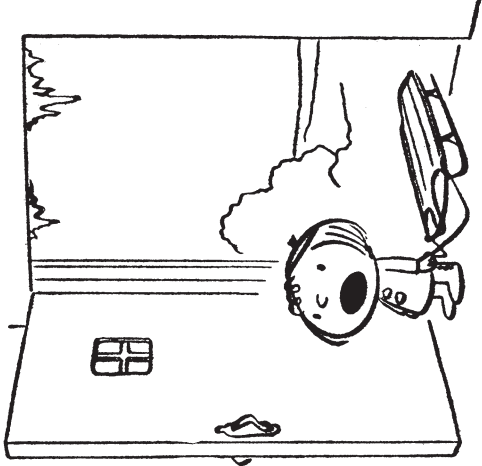

"LITTLE JIMMIE SLID CLEAR TO THE EDGE OF THE WORLD, AND FELL RIGHT OVER!"

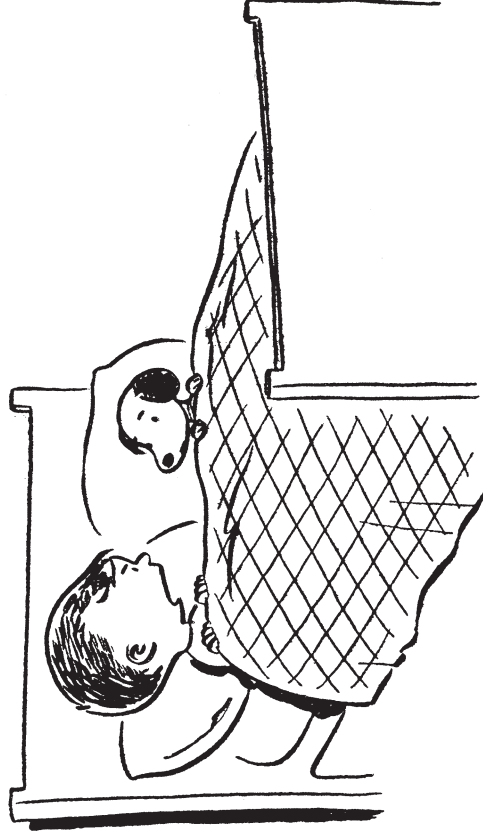

"REMEMBER NOW...NO MORE OF THIS TURNING OFF THE ALARM, AND GOING BACK TO SLEEP!"

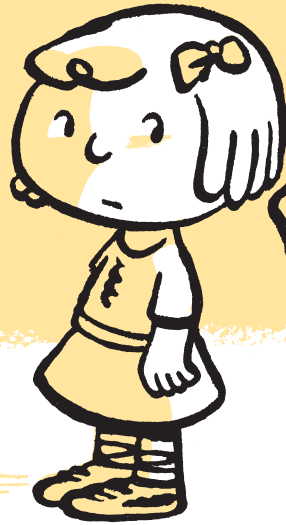

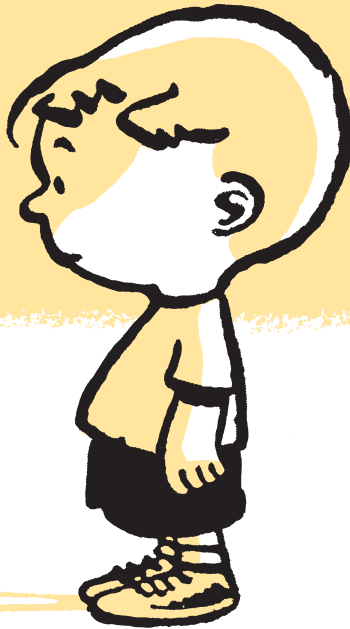



INDEX

“Aaugh!”...67, 125, 128
Andy...114–115, 117
April Fool...40
Astaire, Fred...96
banjo...117
barber...48
baseball...25, 30, 34, 39–40,
45–46, 48, 50–51, 57,
66–67, 71, 75–76, 82,
84–85, 100, 104, 110, 124
basketball...26, 73, 101,
151
beach...93, 117
Beagle Scouts...10, 68
bean bags...6, 27–28, 30,
40, 46
bedtime existentialism...30
Beethoven, Ludwig
Van...46
Bible...73
birdbath...102

blanket...4, 9, 14–15, 34,
49, 80–81, 125, 136
“blockhead”...32, 39
body language...56, 58, 65,
68, 102, 113, 137
“Bonk”...72, 110, 118
Brown, Charlie...2–3, 6–8,
10, 12–13, 15, 17, 19–21,
24–25, 27–28, 30–31,
33–34, 36, 38–43, 45–52,
54, 56–58, 61–62, 65–79,
81–86, 90–91, 93–97,
99–106, 108, 110, 112,
115, 117, 123–124, 126–
133, 135–137, 139–140,
144, 147, 151, 153–154,
156–157, 159, 161, 163–
164

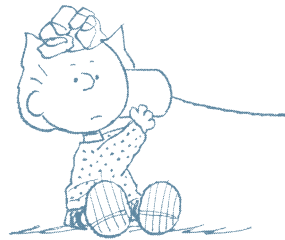

Brown, Sally...6–10, 12–13,
17–18, 22, 25, 27–28, 30,
33, 36, 40–41, 46, 49, 54,
57–58, 69, 73–75, 78–79,
82–84, 88, 90, 93–94, 96,
99–102, 105, 108, 117,

123–124, 126–127, 131–
132, 135–136, 144, 146–
147, 151, 153–154, 156–
157, 163
bus stop...3, 64, 108, 126,
135, 149
cactus...1, 55, 60–61, 77,
82, 93, 99, 107, 109, 114,
120–122, 130, 145
camp...83
cardboard box...146
cards (playing cards)...16,
29, 36, 53, 64, 115, 134
Cartoonists Day (May
5)...54
catch...11, 27
Christmas...2, 145, 151,
153–154, 156
“Clomp”...125
comic books...103, 109, 111
cookies...15
Daffy Duck (charac-
ter)...162
dancing...9, 96
Dentist, The...118
“D-minus”...117
dog dish...3, 8, 23, 27, 52,
56, 58, 69, 86, 88, 91, 106,
112, 124, 127, 162
dog food...24, 27, 52, 69,
86, 88, 91, 112, 161
Donald Duck (charac-
ter)...109
Don Quixote...70

doughnuts...7
drawing...18, 31
Emily...96–97
Father’s Day...74
field trip...12
fishing...75
football...118, 128, 139, 158
Franklin...3, 10, 33, 85,
133
Fred Flintstone (charac-
ter)...96
golf...22, 47, 60
“Good Grief!”...125, 128
Grandfather...22
Great Gatsby, The...10, 97
“Great Pumpkin”...131
guard dog...4
Harry Potter (charac-
ter)...135
hockey...104



homework...6–7, 31, 36,
57, 100, 123

ice...136
 Joe Blackjack...16
 “Joy to the World” (carol;
 Watts, John)...145
 kindergarten...63, 66, 109,
 111, 116, 118, 123, 135,
 138, 162
 King, Billie Jean...162
 kites...28
 “Klunk!”...64, 76



letter(s)...22
 Little Pigtailed Girl...3, 9,
 12–13, 18, 31, 63, 66, 85,
 109, 111, 116, 118, 123,
 135, 138, 148, 162
 Long John Silver (charac-
 ter)...162
 Louis XIV...116
 lunch...10
 Lydia...36
 mailbox...20, 95, 163
 marbles...36
 Marcie...3, 6, 15, 21, 33,
 40, 42–43, 45, 51–52, 55,
 60–61, 63, 67, 70, 78–79,
 88, 106, 112, 117–118,

132–133, 139, 147–148,
 153, 157–158
 McGwire, Mark.... 25
 Mickey Mouse (charac-
 ter)...109
 Monet, Claude...3
 Moses...73
 movie theater...10, 25, 33,
 69
 music...35, 38, 72, 97
 newspaper...136
 New Year's...1
 Nightingale, Florence...116
 Olaf...114–115, 117
 Paine, Thomas...66, 92
 Peggy Jean...83
 Peppermint Patty...3, 6,
 15, 21, 24, 33, 36, 40,
 42–43, 45, 51–52, 55,
 60–61, 63, 67, 70, 78–79,
 88, 106, 112, 117–118,
 126, 129–130, 132–133,
 139, 141, 147–148, 153,
 157–158
 piano...35, 38, 72, 106
 Pigpen...108
 Playground...101
 psychiatric help...41

HA HA HA HA HA!



pumpkin(s)...131
 Pyle, Ernie...136
 rain...3, 39, 49, 75, 90,
 120–121, 126, 157–158,
 163
 Red Baron, The...86
 Red Riding Hood...126
 root beer...143
 “Rowrghr”...147



sandbox...62
 Santa Claus...144
 Santa Claus (Snoopy
 as)...150
 sarcasm...43–44
 school...3, 6, 13, 15, 21, 31,
 33, 42, 51–52, 55, 60–61,
 64, 67, 108–109, 111–112,
 116–117, 123–124, 126,
 135, 138, 148, 162
 school bus...12, 64, 149
 Schroeder...35, 38–39,
 45–46, 72, 84, 106, 110
 shepherding...34
 skating...137

skateboard...13
 sledding...23, 146
 Snoopy...1, 3–5, 7–8,
 10–11, 13, 16–17, 19–27,
 29–31, 34–35, 37–39,
 41–42, 46–47, 49, 51–54,
 56, 58, 62, 64–65, 67–69,
 72–73, 75–76, 79, 81–83,
 86–92, 94–98, 101–103,
 105–106, 112–114, 117,
 119, 124–127, 129–140,
 142–143, 147–148, 151–
 152, 154, 155–157, 159–
 160–161, 164–165
 snow...17, 142, 146, 148,
 150–152, 154–155, 157,
 159–160
 snowball...157
 snowman...14, 150, 154–
 155
 soccer...4, 109
 Spike...55, 60–61, 77, 82,
 93–94, 99, 107, 109, 114,
 120–122, 130, 143, 145,
 153
 supertime (for
 Snoopy)...52, 69, 86, 127
 Tarzan (character)...109,
 111
 teacher...6, 15, 18, 31, 33,
 36, 42–43
 telephone...6, 18, 24, 40,
 52, 58, 61, 75, 78, 83–84,
 139–141, 153, 156, 164

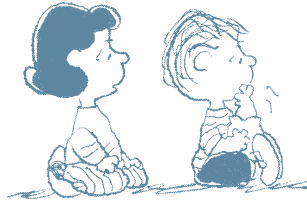

television...9, 15, 18, 27, 30,
40, 49, 59, 82, 88, 102,
141, 153
tests...51-52, 112, 117
Thanksgiving...141
Torre, Joe...156
tumbleweed...82, 93-94,
153
typewriter...4, 8, 22, 81, 95,
119, 138, 140, 151, 164-
165
Valentine's Day...17-21, 24



Van Pelt, Linus...2, 4,
9-10, 12-15, 18, 24-25,
33-34, 36, 39, 46, 49-50,
59, 69-70, 80-81, 84, 102-

103, 108, 125-126, 131,
133, 135-136, 139, 144,
146, 150, 157
Van Pelt, Lucy...1, 5, 9-10,
12-16, 18, 22, 25, 27,
30-32, 34, 39, 41, 43,
44-45, 48, 50, 57-59,
62-63, 66-67, 70, 75-76,
81, 84-85, 87, 100, 103-
105, 110, 116, 118-119,
126, 128, 135, 138, 141-
142, 149-150

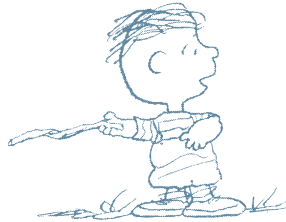

Van Pelt, Rerun...1, 3, 5,
9-13, 16, 18-19, 26-27,
29, 31, 32-34, 36, 39,
43-44, 48-49, 51, 53-54,
57, 62-64, 66, 71-73,
80-81, 85, 87, 89, 94, 98,
100, 102-103, 105, 109,
111, 113, 115-116, 118,
123, 126-128, 133, 135,
138, 141-142, 148-149,
151, 159, 162
"What Is So Rare as a Day

in June"(poem; Lowell,
James Russell)...67



Woodstock...10, 14, 21-23,
31-32, 58, 64, 67-68, 72,
75, 87-88, 92, 102, 121,
129, 134, 139, 142, 148,
152, 154-156, 160

Woodstock's friends (Bill,
Conrad, Harriet, Olivier,
Raymond, Wilson)...10,
14, 31-32, 68, 134, 139
"woof"...4, 73, 83-84, 147
World Famous
Attorney...126, 156

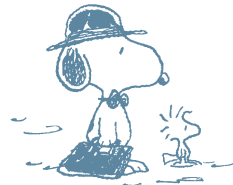

World Famous
Author...81, 95, 119, 138,
140, 151

World Famous Orthopedic
Surgeon...103
World Famous Patriot
Soldier...92, 152, 160
World Famous Sergeant-
Major of the Foreign
Legion...62, 69, 130
World War I...143
World War I Flying
Ace...86, 134, 143
writing...81, 95, 114, 119,
135, 138, 140, 144, 151,
156, 164-165
Wyeth, Andrew...13
Zamboni...131

Charlie Brown, Snoopy,
Linus, Lucy...how can I ever
forget them....

Charles M. Schultz



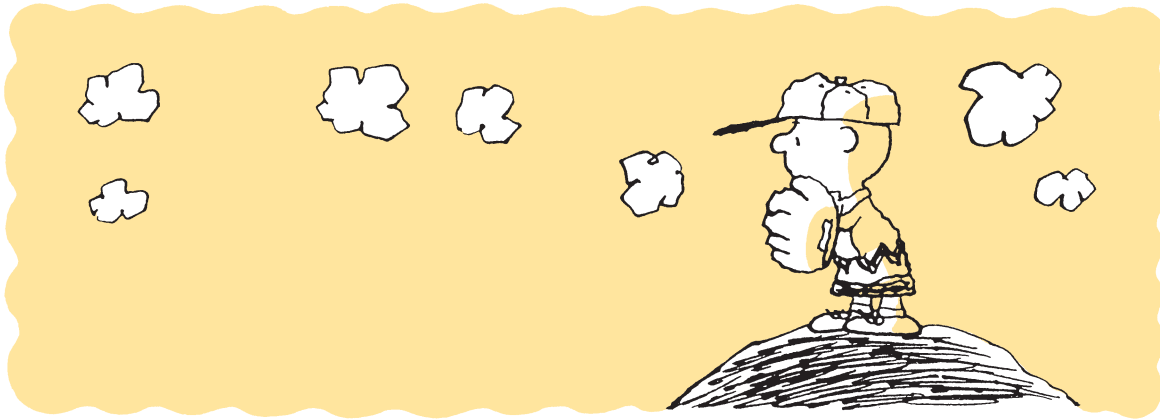

CHARLES M. SCHULZ • 1922 TO 2000

Charles M. Schulz was born November 26, 1922, in Minneapolis. His destiny was foreshadowed when an uncle gave him, at the age of two days, the nickname “Sparky” (after the racehorse Spark Plug in the newspaper strip *Barney Google*).

Schulz grew up in St. Paul. By all accounts, he led an unremarkable, albeit sheltered, childhood. He was an only child, close to both parents. His eventual career path was nurtured by his father, who bought four Sunday papers every week — just for the comics.

An outstanding student, he skipped two grades early on, but began to flounder in high school — perhaps not so coincidentally at the same time kids are going through their cruelest, most status-conscious

period of socialization. The pain, bitterness, insecurity, and failures chronicled in *Peanuts* appear to have originated from this period of Schulz’s life.

Although Schulz enjoyed sports, he also found refuge in solitary activities: reading, drawing, and watching movies. He bought comic books and Big Little Books, pored over the newspaper strips, and copied his favorites — *Buck Rogers*, the Walt Disney characters, *Popeye*, *Tim Tyler’s Luck*. He quickly became a connoisseur; his heroes were Milton Caniff, Roy Crane, Hal Foster, and Alex Raymond.

In his senior year in high school, his mother noticed an ad in a local newspaper for a correspondence school, Federal Schools (later called Art

Instruction Schools). Schulz passed the talent test, completed the course, and began trying, unsuccessfully, to sell gag cartoons to magazines. (His first published drawing was of his dog, Spike, and appeared in a 1937 *Ripley's Believe It or Not!* installment.)

After World War II had ended and Schulz was discharged from the army, he started submitting gag cartoons to the various magazines of the time; his first breakthrough, however, came when an editor at *Timeless Topix* hired him to letter adventure comics. Soon after that, he was hired by his alma mater, Art Instruction, to correct student lessons returned by mail.

Between 1948 and 1950, he succeeded in selling 17 cartoons to the *Saturday Evening Post* — as well as, to the local *St. Paul Pioneer Press*, a weekly comic feature called *Li'l Folks*. It ran in the women's section and paid \$10 a week. After writing and drawing the feature for two years, Schulz asked for a better location in the paper or for daily exposure, as well as a raise. When he was turned down on all three counts, he quit.

He started submitting strips to the newspaper syndicates. In the spring of 1950, he received a letter from the United Feature Syndicate, announcing its interest in his submission, *Li'l Folks*. Schulz boarded a train in June for New York City; more interested in doing a strip than a panel, he also brought along the first installments

of what would become *Peanuts* — and that was what sold. (The title, which Schulz loathed to his dying day, was imposed by the syndicate). The first *Peanuts* daily appeared October 2, 1950; the first Sunday, January 6, 1952.

Prior to *Peanuts*, the province of the comics page had been that of gags, social and political observation, domestic comedy, soap opera, and various adventure genres. Although *Peanuts* changed, or evolved, during the 50 years Schulz wrote and drew it, it remained, as it began, an anomaly on the comics page — a comic strip about the interior crises of the cartoonist himself. After a painful divorce in 1973 from which he had not yet recovered, Schulz told a reporter, “Strangely, I’ve drawn better cartoons in the last six months — or as good as I’ve ever drawn. I don’t know how the human mind works.” Surely, it was this kind of humility in the face of profoundly irreducible human questions that makes *Peanuts* as universally moving as it is.

Diagnosed with cancer, Schulz retired from *Peanuts* at the end of 1999. He died on February 12, 2000, the day before his last strip was published (and two days before Valentine’s Day) — having completed 17,897 daily and Sunday strips, each and every one fully written, drawn, and lettered entirely by his own hand — an unmatched achievement in comics.

—Gary Groth



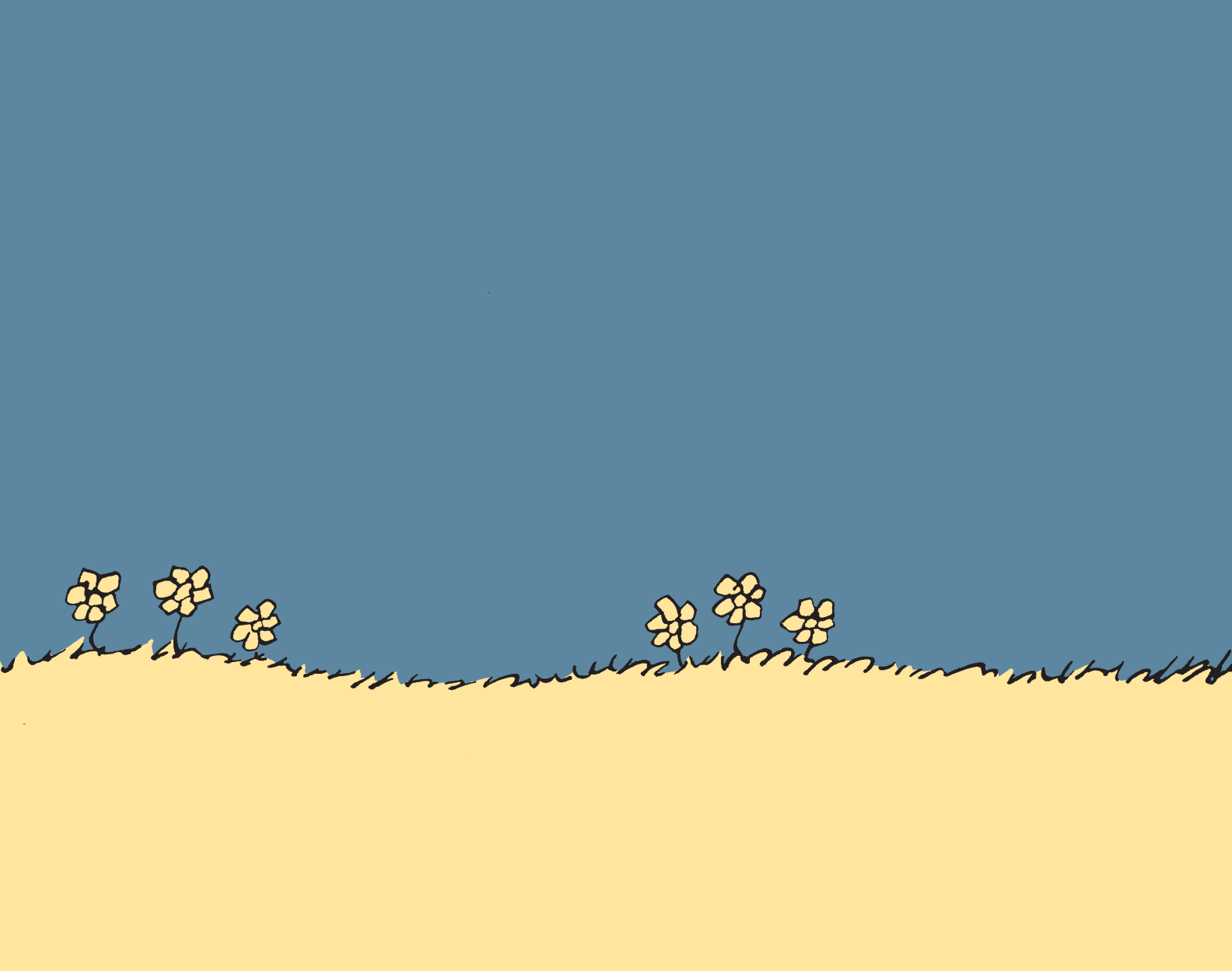

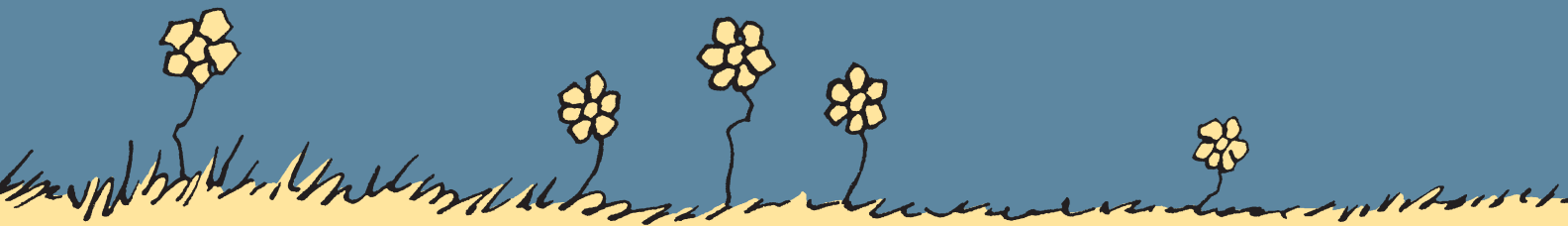



COMING IN *THE COMPLETE PEANUTS VOL. 26*

The final volume of *The Complete Peanuts* series has all of the bonus material and rarities any *Peanuts* fan could ever dream of — a cornucopia of Schulz images and stories, most of which haven't been reprinted since their first appearances in the '50s, '60s, '70s, '80s, and '90s. Vol. 26 includes *Peanuts* comic book stories by Schulz himself; advertising art for both commercial pitches like Ford cars and civic projects like the Clinton administration campaign warning of the dangers of chewing tobacco; *Peanuts* Christmas strips that ran in magazines; golf-, baseball-, and tennis-themed strips and panels — and much more.